

T500 Tag Programming Station

OPERATOR AND MAINTENANCE MANUAL

DOCUMENT: UM 360420-830

REVISION: J

DATE: 28 Mar 2022

REVIEWERS:

Ed Rolo Director of Programs

Dan Terrier Manager, Software Design

Jajeev Kohli Director, Engineering

Joe Bianchini Vice President, Operations

Rick Gegenheimer Vice President, Operations USA

Paul Manuel Vice President, Sales and Marketing

APPROVAL:

Richard Turnock VP Engineering & CTO

This page intentionally left blank.

T500 Tag Programming Station

OPERATOR AND MAINTENANCE MANUAL

DOCUMENT: UM 360420-830

REVISION: J

DATE: 28 Mar 2022

Editor: Scott Garlick

Kapsch TrafficCom Canada Inc.

6020 AMBLER DRIVE
MISSISSAUGA, ON L4W 2P1
TEL: (905) 624-3020
FAX: (905) 625-6197

2855 PREMIERE PARKWAY, SUITE F
DULUTH, GA 30097
TEL: (678) 473-6400
FAX: (678) 473-9003

NOTE: This device complies with Part 15 of the FCC Rules. Operation is subject to the following two conditions: (1) this device may not cause harmful interference and (2) this device must accept any interference received, including interference that may cause undesired operation.

NOTE: This equipment has been tested and found to comply with the limits for a Class A digital device, pursuant to Part 15 of the FCC Rules. These limits are designed to provide reasonable protection against harmful interference when the equipment is operated in a commercial environment. This equipment generates, uses, and can radiate radio frequency energy and, if not installed and used in accordance with the instruction manual, may cause harmful interference to radio communications. Operation of this equipment in a residential area is likely to cause harmful interference in which case the user will be required to correct the interference at their expense.

Changes or modifications not expressly approved by Kapsch TrafficCom could void FCC compliance and the authority to operate the equipment.

SOFTWARE/FIRMWARE NOTE

The current software set is identified in the Software Release document.

FACTORY SUPPORT SERVICE

For Return Material Authorization (RMA) numbers please telephone: 905 624-3020.

For service information and other requests please FAX: 905-625-6197

© Kapsch TrafficCom Canada Inc. 2022

COPYRIGHT STATEMENT

All information contained herein is proprietary to, and may only be used with express, written permission from, Kapsch TrafficCom Canada Inc. Copyright © 2022 Kapsch TrafficCom Canada Inc.

IMPORTANT!

NOTICE OF PATENTS:

Kapsch TrafficCom

has patented or has patents pending on critical design features of the item or items described herein. Contact Kapsch TrafficCom for all queries regarding patents.

NOTICE

The information presented in this document is current although it is subject to change. As such, **Kapsch TrafficCom** assumes no liability on behalf of the USER with respect to interpretation based on the use of this information

Windows and Excel are registered trademarks of Microsoft Corporation in the United States and other countries.

Document Revision Control

Applicability: Operator and Maintenance Manual

Revision: J

Version Date	Revision	Changes	Editor
28 Mar 2022	J	ECN 22021 address change for US office	B. Mac
15 Nov, 2018	I	ECN 18057 Added upgrade procedure on Agency Mapping file. Updated launch instruction for Windows Vista and above.	S. Lee
12 Jan 2018	H	ECN 18001 Updated description of template file creation in section 3 and 7.	S. Lee
16 Jan 2017	G	ECN 16092 – Updates to Copyright and Footer – Permit access to the document without requiring a NDA.	E. Rolo
5 Dec 2014	F	ECN: 14119 Updated installation instruction in section 5 for the support of Windows 7 /8 /8.1	S. Lee
26 Aug 2014	E	ECN: 14087. Cable IDs added to diagram in section 4	R. Mac.
20 June 2014	D	ECN:14054 In the Appendix, replaced the diagram for the FME OBU in the drawer with a new diagram that shows the updated orientation for the FME in the drawer	E. Rolo
20 June 2012	C	ECN:12064 Added the section: Placement of OBUs in the AU Drawer Cradle to the Appendix Added information about HOT and Feedback (FB) tags. Updated TSP icon Added section on Viewing HOT/HOV data for HOT and Feedback tags. Updated Table 7-3: The Log Files General update of manual using new template KTCIVHSQA180 Rev F June, 2012 specifications.	M. Kleiza
29 June 2011	B	General manual overhaul for initial release	S. Garlick
22 Sep 2010	A1	Initial Draft	N/A

Table of Contents

1.	About this Manual	10
	Warnings and Cautions	10
	Warnings	10
	Cautions	10
	OPERATING INSTRUCTIONS.....	11
2.	Overview	12
	Introduction	12
	The TPS system components	12
	Tag cradle inside AU drawer	13
	TPU front panel LEDs	13
	The TPS Interconnections	14
	The TPU and AU communication ports	15
	User Interface Nomenclature	16
	Help files	17
	Types of operators	17
	Users	17
	Supervisors	17
	Forced logout	18
	Reading and programming tags	18
	Automatic Write Enabled	19
3.	Operating Procedures	20
	Starting the TPS Software	20
	Authenticating the TPS software	20
	Exiting the TPS software	21
	Logging in	21
	Logging out	21
	Creating a password	22
	Changing a password	23
	Reading tags	23
	Programming tags	24
	Loading a template	25
	Unloading a template	25
	Viewing User and Supervisor Account Information	25
	Viewing Tag data vs. Viewing Template data	27
	Viewing Factory/Agency data	28
	Viewing Agency (Custom) Data	29
	Viewing Scratch Pad data	30
	Viewing Scratch Pad (Custom) data	31
	Viewing Toll/Balance data for toll balance tags	32
	Viewing HOT/HOV data for HOT and Feedback tags	33
	Printing the contents of the tag currently displayed	34
	Command and Controls	34

MAINTENANCE PROCEDURES	44
4. Theory of operation	45
TPS System overview	45
5. Installation	46
System component interconnections	46
Customer-Supplied TPS Computer requirements	46
Installing the TPS software	47
Installing /Upgrading the agency mapping file	48
Launching the TPS software for the first time	48
Setting the logout timer.....	49
Entering the Agency name	49
Setting the communications parameters.....	50
Setting automatic tag reading	51
Setting automatic tag writing	51
Setting the default view page.....	51
6. Troubleshooting	52
Diagnostics	52
Viewing the software and firmware versions	52
Communication error	53
Authentication error	54
Login error.....	55
Configuration error	55
Read Failed Error	56
Write Failed Error.....	57
7. Maintenance Procedures	59
Creating a new User or Supervisor	59
Deleting a User or Supervisor	59
Creating/Modifying a template file	60
Changing Factory/Agency data.....	61
Changing custom Agency data.....	62
Creating custom Agency data field	63
Creating values for an Agency data field.....	67
Deleting a custom Agency data field	70
Changing Scratch Pad data	71
Changing custom Scratch Pad data	72
Creating custom Scratch Pad data field	73
Deleting a custom Scratch Pad data field.....	74
Changing Toll/Balance data.....	75
Changing HOT/HOV & FB data.....	76
Saving a Template	77
Viewing and/or Printing Log Files	78
Appendix.....	79
Placement of OBUs in the AU Drawer Cradle	79
Placement of the LCD in the AU drawer:	79

T500 Tag Programming Station

Placement of the LPT in the AU drawer:.....	80
Placement of the CVO in the AU drawer:	81
Placement of the G4 OBU in the AU drawer:	82
Placement of the G3B OBU in the AU drawer:	83
Placement of the FME OBU in the AU drawer:.....	84
Accessing Documentation	86
Acronyms	87

List of Figures

Figure 2-1: TPS System Components 12

Figure 2-2: TPU Front Panel 13

Figure 2-3: TPS System Overview Schematic 14

Figure 2-4: TPU and AU Ports 15

Figure 2-5: Forced Logout Indication 18

Figure 2-6: The Read/Program Status Bar 18

Figure 2-7: Auto Write Enabled Warning Message 19

Figure 3-1: The Users Window 26

Figure 3-2: Template File Not Loaded 27

Figure 3-3: Template File Loaded 27

Figure 3-4: Modified Template Data 28

Figure 3-5: Factory/Agency Data Page 28

Figure 3-6: Agency (Custom) Data Page for standard tags 29

Figure 3-7: Scratch Pad Data Page 30

Figure 3-8: Scratch Pad (Custom) Data Page 31

Figure 3-9: Toll/Balance Data Page 32

Figure 3-10: HOT /HOV & FB Data Page 33

Figure 5-1: TPS Configuration Window 50

Figure 6-1: Communication Problem between TPU and Customer-Supplied Computer 53

Figure 6-2: TPU status – not connected to customer-supplied computer 53

Figure 6-3: TP status – connected to customer-supplied computer 53

Figure 6-4: Authentication Error Message 54

Figure 6-5: Login Error Message 55

Figure 6-6: Read Failed Error Message 56

Figure 6-7: Typical Read Error Message Details 56

Figure 6-8: Write Failed Error Message 57

Figure 6-9: Typical Write Error Message Details 57

Figure 7-1: Factory /Agency page 61

Figure 7-2: Agency (Custom) page 62

Figure 7-3: Custom Fields dialog 63

Figure 7-4: Add Field dialog 64

Figure 7-5: Start Bit for First Custom Agency data field (for Standard Tags) 64

Figure 7-6: Start Bit for First Custom Agency data field (for Toll/Balance Tags) 64

Figure 7-7: Example of Start Bit for Second Custom Agency data field (for Standard Tags) 66

Figure 7-8: Example of Reserved Bit for Second Custom Agency data field (for Standard Tags) 66

Figure 7-9: Custom Fields dialog box with added data fields 67

Figure 7-10: Values Window of data field 67

Figure 7-11: Add Value dialog 67

Figure 7-12: Values window with added values 68

T500 Tag Programming Station

Figure 7-13: Custom Agency Data Available for Selection	69
Figure 7-14: Programmed Custom Agency Data	70
Figure 7-15: Scratch Pad page	71
Figure 7-16: Scratch Pad (Custom) page	72
Figure 7-17: Standard custom Scratch Pad data	73
Figure 7-18: Toll/Balance custom Scratch Pad data	73
Figure 7-19: Toll/Balance page	75
Figure 7-20: HOT /HOV & FB page	76

List of Tables

Table 3-1: User Information Fields	26
Table 5-1: TPS System Component Interconnections	46
Table 6-1: Read Errors, Causes, and Solutions	56
Table 6-2: Write Errors, Causes, and Solutions	58
Table 7-1: Data Fields and Values (used in task example)	63
Table 7-2: Bit Width of Values	65
Table 7-3: The Log Files	78

1. ABOUT THIS MANUAL

Kapsch TrafficCom supplies the T500 Tag Programming Station (TPS). The T500 provides a means for reading and programming the data stored in Kapsch TrafficCom tags. This manual is divided into two parts; Operator Instructions and Maintenance Instructions. See the table of contents for more details on each section.

This manual is used as the main document provided during any training course given to T500 TPS maintenance and service personnel. This manual also serves as a reference for Kapsch-certified technical service personnel in the field once training has been completed.

NOTE: Hardware failures are beyond the scope of this manual. Return failed equipment to Kapsch TrafficCom for service.

Warnings and Cautions

Warnings

Warnings indicate a risk of bodily harm and include a symbol indicating the type of injury that is at risk.

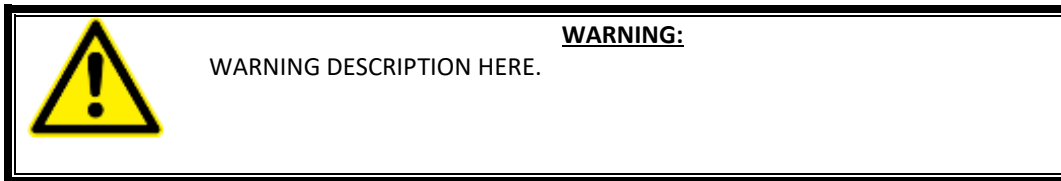

No warnings currently appear in the manual:

Cautions

Cautions indicate a risk of damage to equipment or loss of data.

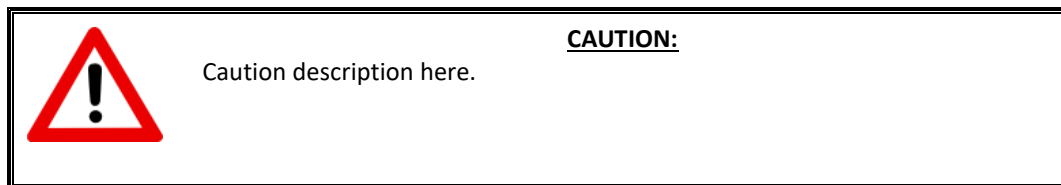

The following caution appears in the manual:

Tag data is automatically overwritten when the **Automatic write enabled** message is displayed. Ensure you want the current template data written to the tag before closing the AU drawer.

OPERATING INSTRUCTIONS

2. OVERVIEW

Introduction

The T500 Tag Programming Station (TPS) allows users to read data stored in a tag and also program a tag with Agency data such as the vehicle type and vehicle weight. A properly mounted tag in a closed Antenna Unit (AU) drawer can be read and programmed either automatically or manually. TPS software, supplied with the TPS, is used to operate the TPS and provides the User Interface (UI). Factory data such as the tag type and serial number cannot be modified using the TPS.

There are two factory configurations of the T500 available; one for IAG tags, and one for non-IAG tags.

NOTE: An IAG tag is not readable or programmable in a T500 that was factory-configured for non-IAG use.

The TPS is intended for use in an office environment under controlled environmental (temperature, humidity and dust) conditions. An Uninterruptable Power Supply (UPS) should be used to provide AC power to the TPS and the customer-supplied computer.

The TPS system components

The TPS consists of:

- a Tag Programming Unit (TPU)
- an Antenna Unit (AU)
- TPS software installed on a customer-supplied TPS computer.

Figure 2-1: TPS System Components

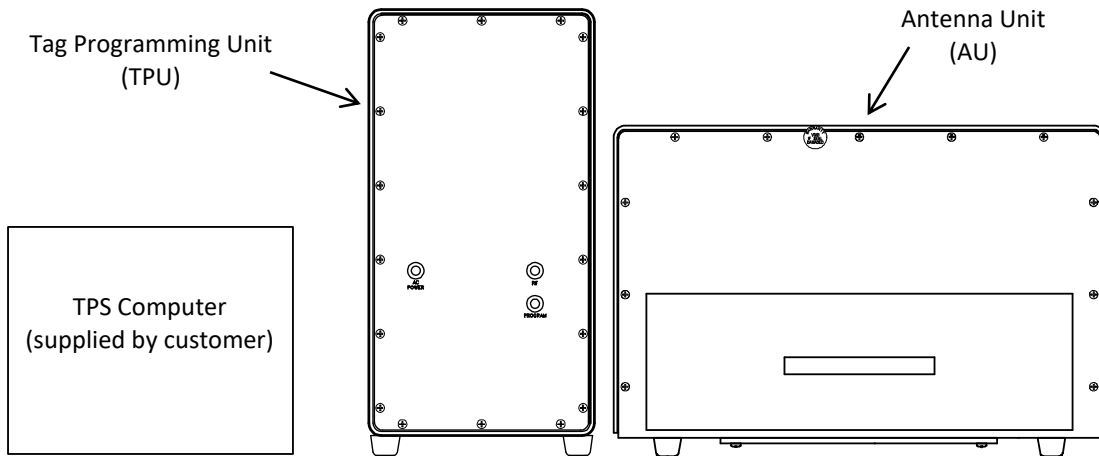

T500 Tag Programming Station**Tag cradle inside AU drawer**

The tag cradle is a foam insert configured to accept Flat Pack Transponders (FPTs), Roof-Mount FPTs, Front Mount Exterior (FME) transponders, License Plate Transponders (LPTs), LCD transponders, the G4 family of transponders, and the High Occupancy Toll (HOT) transponder. You may need to modify older versions of the foam insert to accept FME transponders.

NOTE: Correct alignment of the tag in the cradle is vital for successful communication between the tag and the TPS. See Placement of OBUs in the AU Drawer Cradle, page 79 for examples of correct tag placement.

TPU front panel LEDs

The TPU front panel is equipped with three LEDs:

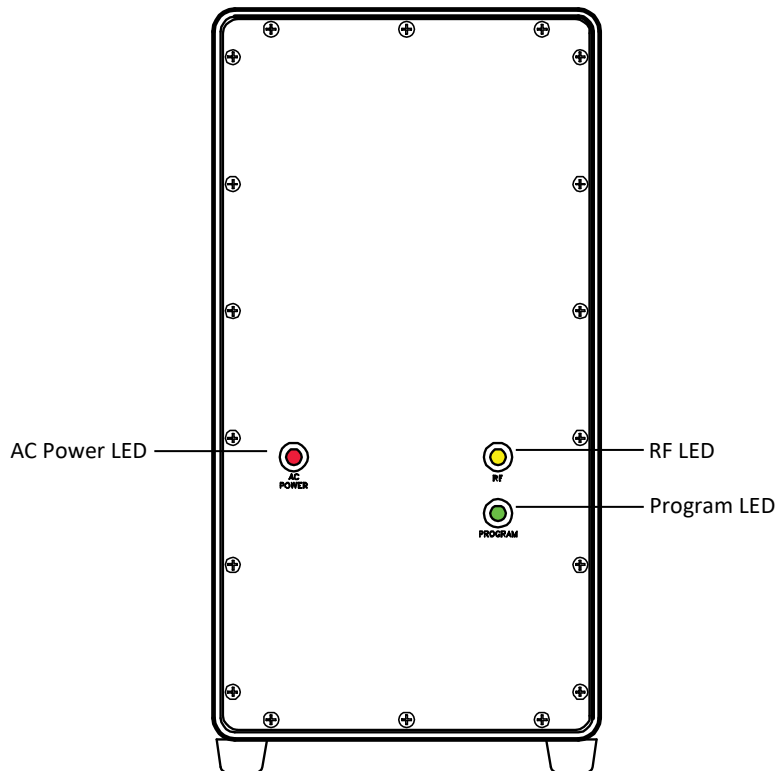
Figure 2-2: TPU Front Panel

T500 Tag Programming Station

- AC POWER** (red): illuminates when AC power is connected to the TPU and the rear TPU power switch is turned on.
- PROGRAM** (green): illuminates after a tag has been successfully programmed. It will remain lit until another Read or Program is attempted.
- RF :** (amber) illuminates momentarily when the TPS has sensed that the AU drawer has closed or while the TPS is successfully communicating with the tag.

The TPS Interconnections

Figure 2-3: TPS System Overview Schematic

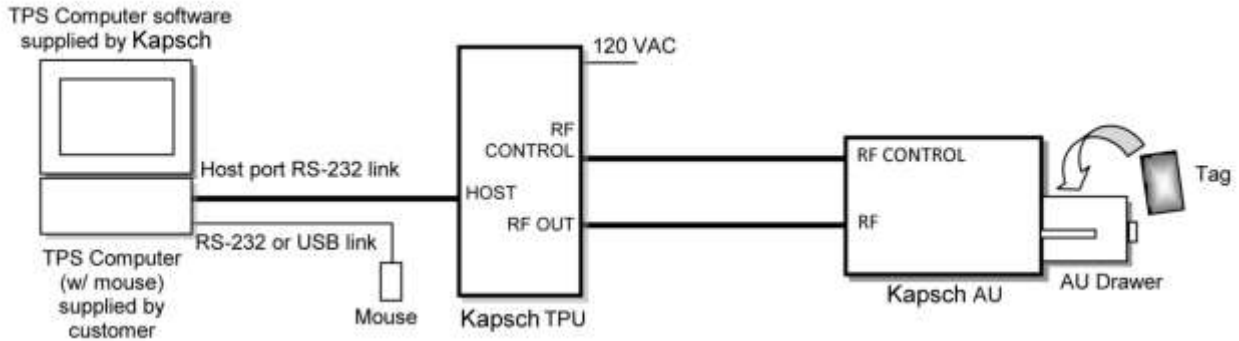

The TPU and AU communication ports

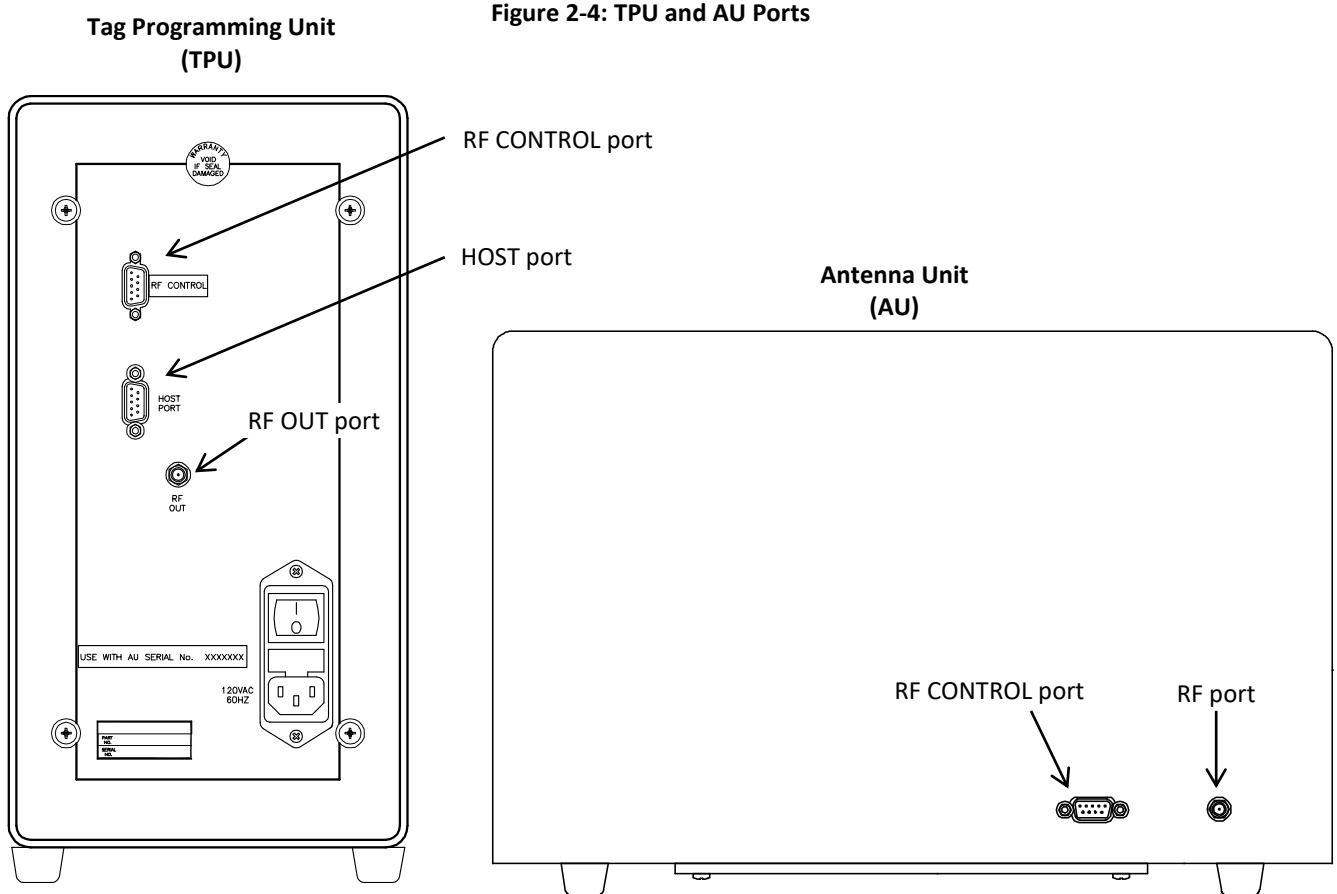

User Interface Nomenclature

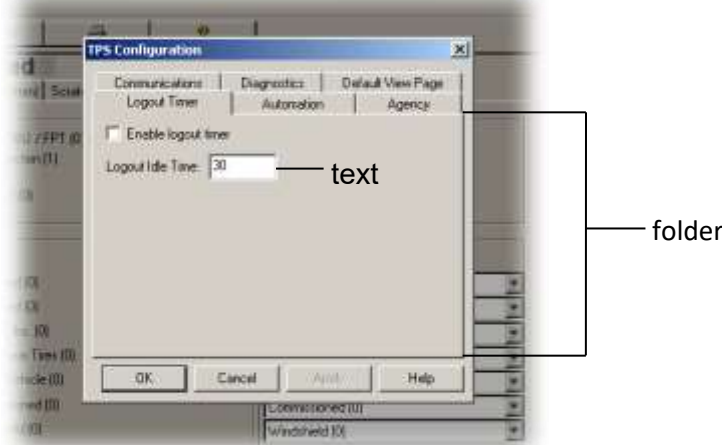
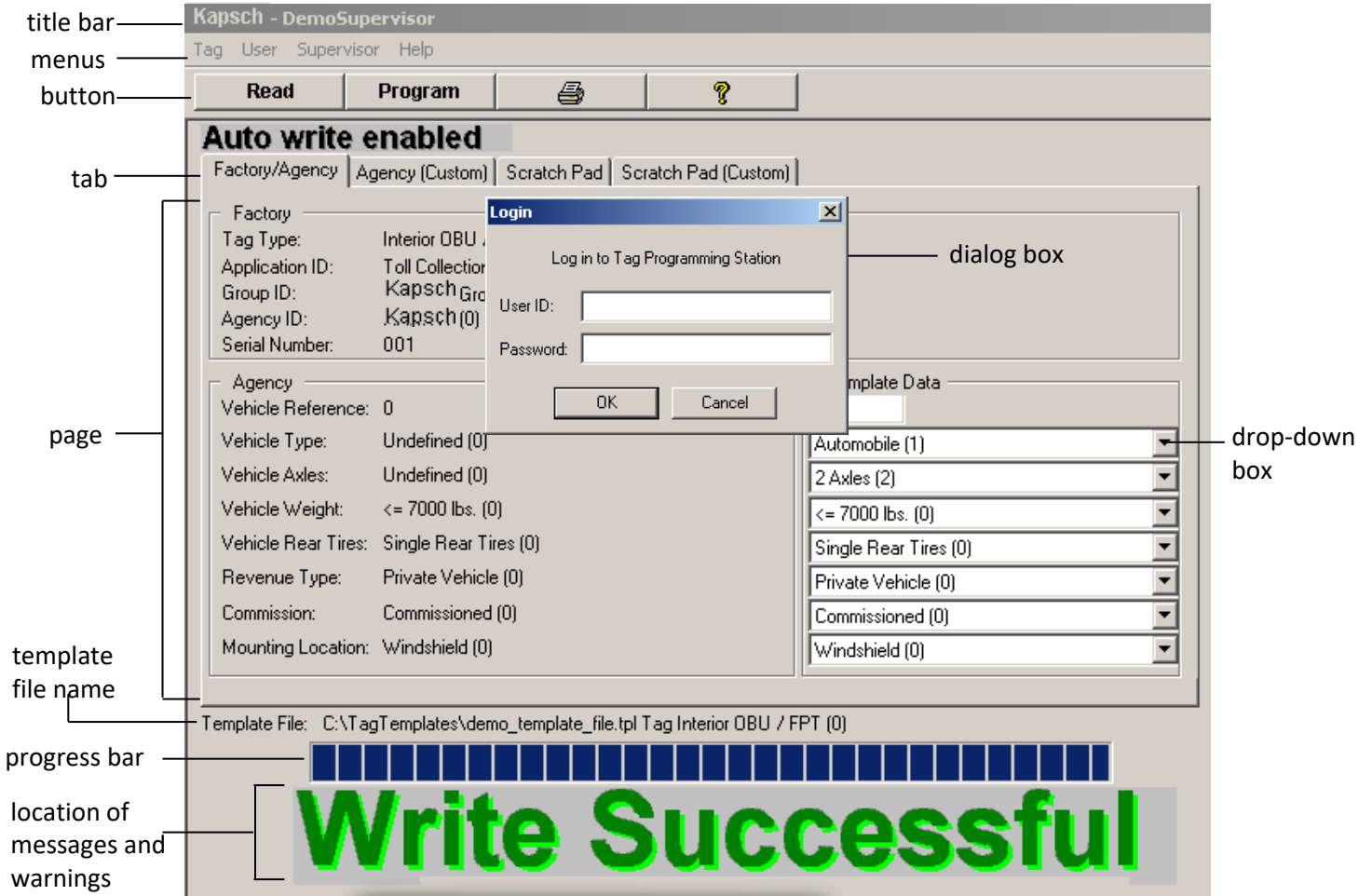

Help files

Help files can be accessed selecting **Help Topics** from the **Help** menu, by pressing the F1 key, by clicking the question mark button, or by selecting **Help** from the pop-up windows.

Types of operators

There are two classes of operators; Users and Supervisors. Your User ID was classified as either a User or Supervisor when the ID was created.

Users

Users' access is limited to the functions required for operating a configured TPS. Users can log in and out of the TPS software, create or change a password, read and program tags, load and unload templates, and print data.

When logged in as a User, the **Tag**, **User** and **Help** menus are available.

Supervisors

Supervisors have access to all TPS software functions. Only Supervisors can add or delete users, create or modify templates, change system preferences or exit the program.

When logged in as a Supervisor, the **Tag**, **User**, **Supervisor** and **Help** menus are available.

Forced logout

A Supervisor can enable a logout timer that automatically logs the operator out of the TPS software after the system has been idle for a predetermined time.

When the logout timer enforces a logout, the **Forced Logout** message appears at the bottom of the main screen. You must log in to continue using the TPS Software.

Figure 2-5: Forced Logout Indication

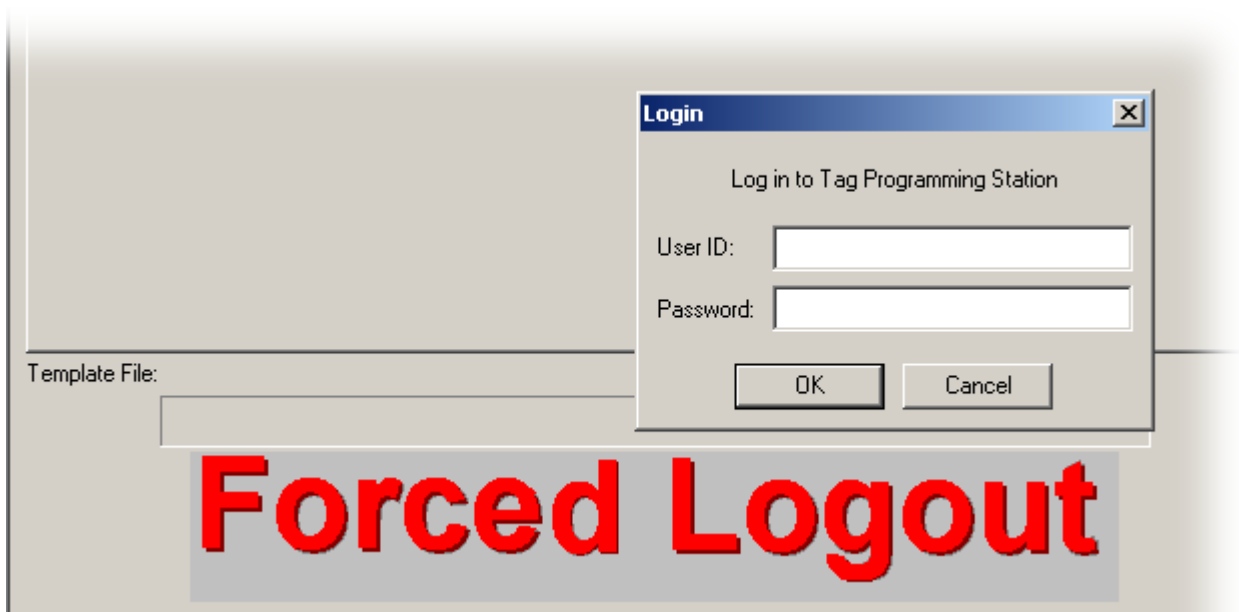

Reading and programming tags

Reading tags with the TPS software allows the user to view the data stored in the tag. Programming the tag allows the user to write data to the tag.

The relative progress of the tag read or write is displayed in the blue status bar:

Figure 2-6: The Read/Program Status Bar

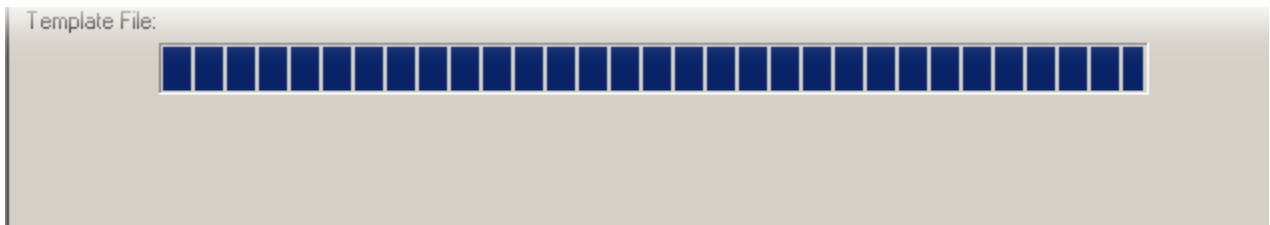

Automatic Write Enabled

The T500 can be configured to program a tag automatically once the AU drawer is closed and the tag has been automatically read. When this feature is enabled (see Setting automatic tag writing, page 51), the **Auto write enabled** caution message is displayed to caution that tag data will be overwritten with the current template data.

Figure 2-7: Auto Write Enabled Warning Message



3. OPERATING PROCEDURES

Starting the TPS Software

1. Ensure the TPS is properly connected to the TPS computer (see System component interconnections, page 46).
2. Contact Kapsch TrafficCom for the latest agency mapping file (see page 48 for upgrading agency mapping file procedure).
3. Launch the TPS software as Administrator by right-clicking the TPS software icon  on the desktop, or by right-clicking **Start→Programs→Kapsch TrafficCom IVHS→T500 Tag Programmer→T500 Tag Programmer (version #)** and select **Run as administrator** option.
4. An authentication code, unique to each TPU, must be entered before the TPS software will run.

Authenticating the TPS software

NOTE: The authorization code is provided by the Kapsch TrafficCom service technician. If an authentication error message is displayed, see Authentication error, page 54 to resolve the problem.



1. When the Authorization Code dialog box appears, enter the authorization code for the TPU and select **OK**.
2. After the TPS software launches, the Login dialog box appears.
3. If this is the first time launching the TPS Software, proceed to Launching the TPS software for the first time **Error! Reference source not found.**, page 48.
4. If the TPS software has been previously launched and Users and Supervisors exist in the system, proceed to Logging in, page 21.

Exiting the TPS software

Prerequisites: You must be logged on as a Supervisor.

1. Select Supervisor → Exit. The TPS software closes.

NOTE: When the TPS software is relaunched (see Starting the TPS Software, page 20), an authorization code unique to each TPS must be entered.

Logging in

Prerequisites: None.

1. Select User → Login.

NOTE: The **User ID** and **Password** are case-sensitive.

2. Type the **User ID** and **Password** in the appropriate text box and select **OK**. The Login dialog box appears.

3. If you are logging in for the first time, leave the password text box empty to be prompted to create a password (see Creating a password, page 22).

4. After successfully logging in, the user ID is displayed in the title bar following the agency name. In the example shown, the user ID is DemoSupervisor.

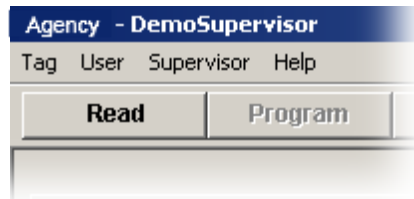

Logging out

Prerequisites: None.

NOTE: Logging out will automatically unload the current template.

1. Select User → Logout.

2. The message “Are you sure that you want to logout?” appears. Select **Yes** to log out.

3. After successfully logging out, the Login dialog box is displayed, waiting for a User or Supervisor to log in.

Creating a password

When a new User or Supervisor has been created, the User or Supervisor needs to log in to create a password for the account.

Prerequisites: Your User ID must have already been created by a Supervisor.

1. Select User → Login. The **Login** dialog box appears.
2. Type your user name in the **User ID** text box. Be sure to leave the **Password** text box empty. Select **OK**.
3. The message “You must create a password” appears. Select **OK** again. The **Create Password** dialog box appears.

NOTE: The user ID and password are case-sensitive. Passwords must be alpha-numeric and 6 to 32 characters long.

NOTE: The User ID and Password must not be the same.

4. Type the new password in the **New Password** text box. Type the new password again in the **Verify Password** text box.
5. Select **Ok** to create the new password. After the password is created, the User or Supervisor will be automatically logged in. The new password is required the next time you log in.

Changing a password

This procedure changes the password for the user currently logged into the TPS software. The user name of the person logged in is displayed in the title bar.

Prerequisites: You must be logged in.

1. Select User → Change Password. The **Change Password** dialog box appears.
2. Type the current password in the **Current Password** text box. Type the new password in the **New Password** and **Verify Password** text boxes. Select **OK** to make the change.
3. If the New Password and the Verify Password do not match, the message “Your new password and the verify password are not the same” is displayed. Repeat the procedure to change your password.

Reading tags

Tags can be read either automatically or manually. If you are automatically reading the tag data, be aware that the tag data will be overwritten after being automatically read whenever automatic tag writing is enabled.

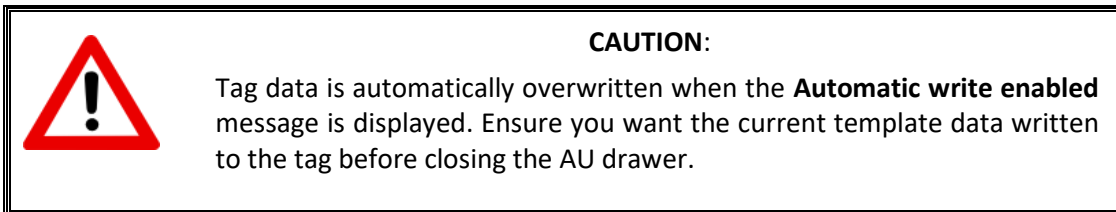

Prerequisites: None.

1. To begin reading a tag, place a tag into the foam insert in the AU drawer (see Placement of OBUs in the AU Drawer Cradle, page 79).

To Manually Read a Tag:

- a. Close the AU drawer.
- b. Click the **Read** button or select **Read Tag** from the **Tag** menu. The RF LED on the front panel of the TPS lights momentarily, indicating the TPS has successfully communicated with the tag and read the data.

To Automatically Read a Tag

- a. Close the AU drawer. When the door is closed, the RF LED on the front panel of the TPS will light momentarily, indicating the TPS has sensed the AU door has closed. The TPS will then automatically read the tag data.
- b. The message Read Failed appears if the read attempt was unsuccessful. See Read Failed Error, page 56 for a list of possible causes.

Programming tags

Ensure the correct template is loaded (see Loading a template, page 25).

If the correct template does not exist, the Supervisor must create a template (see Creating/Modifying a template file, page 60).

Prerequisites: A template must be loaded.

1. Place a tag into the foam insert in the AU drawer (see Placement of OBUs in the AU Drawer Cradle, page 79).
2. Verify whether automatic tag writing is enabled. "**Auto write enabled**" is displayed to caution the user that automatic tag writing is enabled. If not enabled, program the tag manually. If enabled, the tag will be programmed automatically.

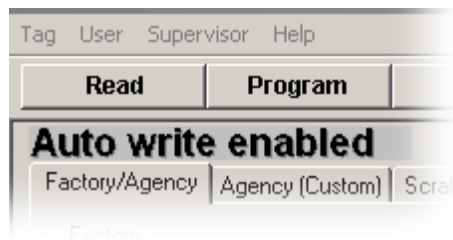

To Manually Program a Tag

- a. Close the AU drawer.
- b. Click the **Program** button or select **Program Tag** from the **Tag** menu.
- c. Within 1 second, **Write Successful** is displayed and the PROGRAM LED on the front of the TPS will light, indicating the tag has been programmed successfully.

To Automatically Program a Tag

NOTE: Automatic programming will not occur if Auto Read is not enabled.

- a. Close the AU drawer.
- b. Within 1 second **Write Successful** is displayed and the PROGRAM LED on the front of the TPS will light, indicating the tag has been programmed successfully.

The message **Write Failed** appears if the program attempt was unsuccessful. See

3. Write Failed Error, page 57).

Loading a template

A template contains preconfigured data fields. Template data can be written to tags once the template is loaded. Each template is designed for one tag type only.

Prerequisites: None.

1. Select User → Load Template.
2. Select the appropriate template file from the list of templates and select **Open**. The default file location for templates is \Tag Template under current TPS application software installed location. However, the Supervisor is able to save template files in any location. If the correct template does not exist, a Supervisor must create a new template (see Creating/Modifying a template file, page 60).
3. The selected template file will be shown at the bottom of the screen.
4. Verify that this is the correct template by reviewing the template data in each tab.
5. If the file selected is not a template file, the error message “**Unable to load template file**” appears. Contact a Supervisor to locate the appropriate template file.
6. Read a tag of the same tag type as the template designed for in order to show all the data fields. If the tag type mismatches, the error message “**The tag type of a tag in the antenna unit does not match the selected template. The template has not been applied.**” will appear.

NOTE: Loaded template data will not be displayed until a tag is read.

Ensure the tag to be programmed is the same type as the loaded template, otherwise, an error message will appear and the template will not be applied .

Unloading a template

Unloading a template will clear the template data being used by the TPS software.

Prerequisites: None.

1. To immediately unload the current template, select User → Unload Template.

Viewing User and Supervisor Account Information

The Users window displays a variety of useful account information.

Prerequisites: You must be logged in as a Supervisor.

T500 Tag Programming Station

1. Select Supervisor → Users. The **Users** window appears, listing any existing Users and Supervisors:

Figure 3-1: The Users Window

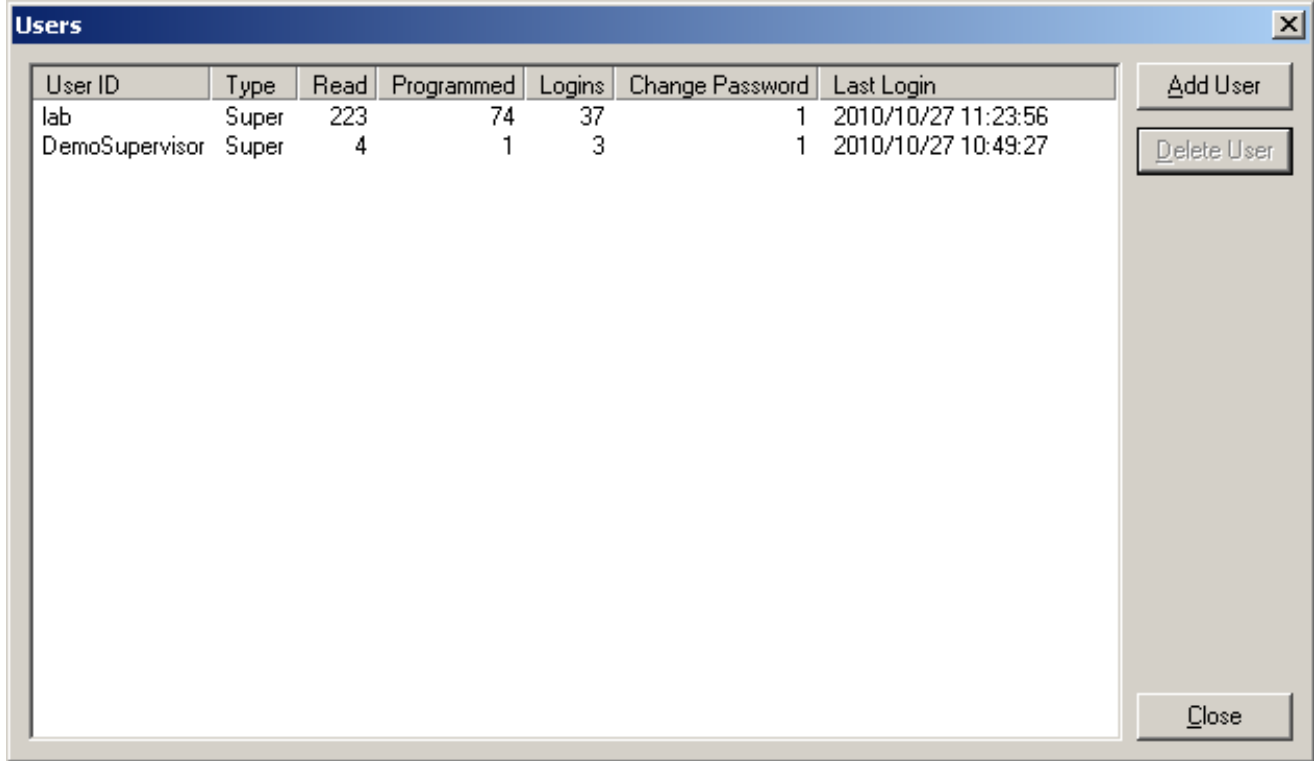

The following Information about the User or Supervisor is displayed in the Users window:

Table 3-1: User Information Fields

Column	Description
User ID	the User ID of each User and Supervisor
Type	the type of user, either Supervisor (Super) or User
Read	the number of tags which have been read by the user
Programmed	the number of tags which have been programmed by the user
Change Password	the number of times the User or Supervisor has changed their password
Last Login	the date and time when the user lasted logged. 'Never Logged In' will be displayed if that user has never logged in

Viewing Tag data vs. Viewing Template data

As a User or Supervisor, you can view the tag or template data by clicking on the page tabs: **Factory/Agency**, **Agency (Custom)**, **Scratch Pad** and **Scratch Pad (Custom)**. Toll/Balance tags display a fifth page of data labeled **Toll/Balance**.

It is important to know whether you are viewing tag or template data. This can be determined by looking at the Template File information near the bottom of the screen:

- You are viewing the tag data of the most recently read tag when no template file is loaded, as indicated by no template file name being displayed, as shown in Figure 3-2.

Figure 3-2: Template File Not Loaded

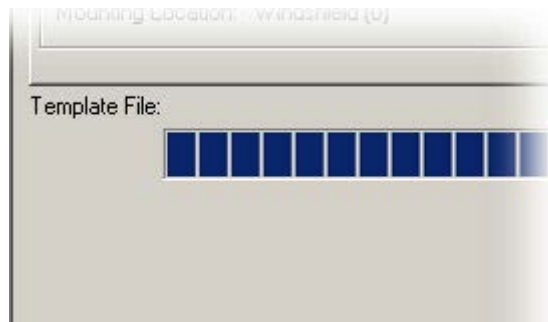

- You are viewing the template data when the template file name and tag type are displayed, as shown in Figure 3-3.

Figure 3-3: Template File Loaded

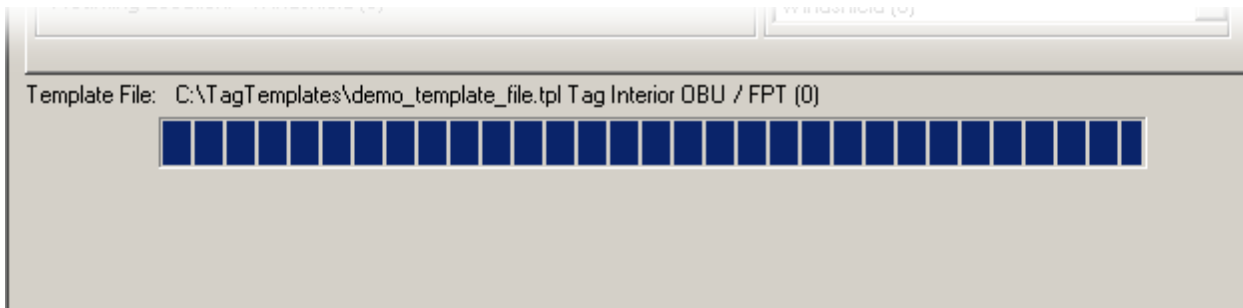

- You are viewing modified template data when the message 'Modified, Should save template before programming tag' is displayed after the template file name, as shown in Figure 3-4.

T500 Tag Programming Station

Figure 3-4: Modified Template Data

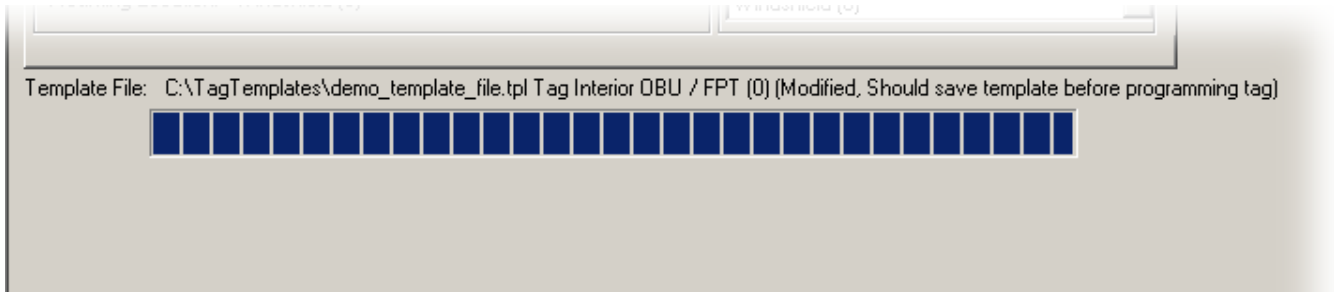

Viewing Factory/Agency data

This page displays the Factory and Agency data. The Factory data cannot be changed. A Supervisor can change Agency data by selecting from the drop-down boxes.

Prerequisites: None.

1. Click on the **Factory/Agency** tab to view the Factory/Agency page.

Figure 3-5: Factory/Agency Data Page

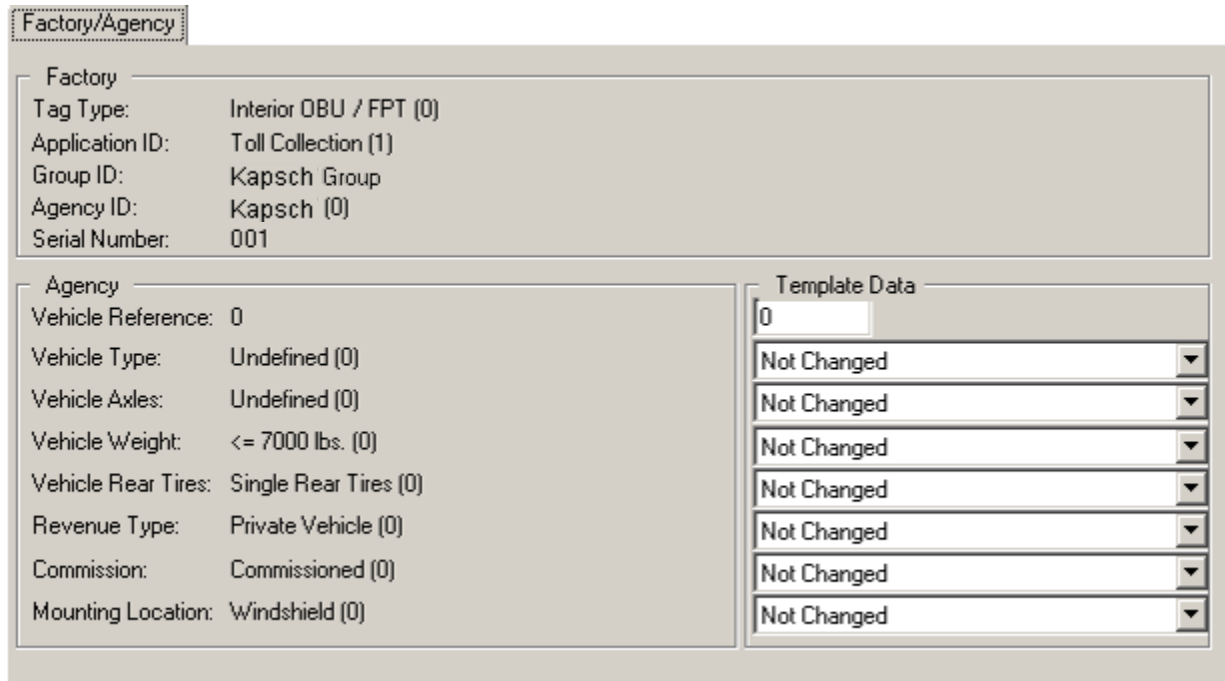

Viewing Scratch Pad data

This page displays the Scratch Pad data. This data is sent to the tag by the toll plaza reader.

Prerequisites: None

1. Click on the **Scratch Pad** tab to view the Scratch Pad page.

Figure 3-7: Scratch Pad Data Page

Scratch Pad

<p>Traffic Management Data</p> <p>Reader ID: 0 Date: Undefined (0) Time: 00:00:00 (0)</p>	<p>Template Setting</p> <p><input checked="" type="checkbox"/> Clear Traffic management Data</p>
<p>Toll Collection Data</p> <p>Agency ID: Kapsch 0) Plaza ID: 0 Lane ID: 0 Date: Undefined (0) Time: 00:00:00 (0) Vehicle Class: 0 Future (Reserved): 0 Txn Number: 0 (0 hex)</p>	<p>Template Setting</p> <p><input checked="" type="checkbox"/> Clear Toll Collection Data</p>
<p>Check Sum</p> <p>Checksum: 10593 (2961 hex)</p>	

Viewing Scratch Pad (Custom) data

This page displays the custom Scratch Pad data. The Supervisor can create up to 10 custom Scratch Pad data fields. The custom Scratch Pad Data is represented at the top of the page by a binary code.

Figure 3-8 shows the page with no custom Scratch Pad data configured. For standard tags, 30 bits are reserved for adding custom Scratch Pad data; for HOT and Feedback (FB) OBUs, 24 bits are reserved; for toll tags, 4 bits are reserved.

Prerequisites: None

1. Click on the **Scratch Pad (Custom)** tab to view the Scratch Pad (Custom) page.

Figure 3-8: Scratch Pad (Custom) Data Page



Viewing Toll/Balance data for toll balance tags

Toll balance tags contain additional data displayed on the Toll/Balance page.

Prerequisites: None

1. Click on the **Toll/Balance** tab to view the Toll/Balance page.

Figure 3-9: Toll/Balance Data Page

The screenshot shows a web interface for configuring a toll tag. At the top, there is a tab labeled "Toll / Balance". Below the tab, the page is divided into two main sections: "Toll Information" and "Internal Use".

Toll Information

Toll Amount:	\$0.00		
Balance:	\$35.55	Not Changed	\$ <input type="text"/>
Low Balance:	Icon Off (0)	Icon Off (0)	
Balance Adjust ID:	Replacement (3)	Not Changed	
Balance Adjust Date:	May 2 (5/2)	Not Changed	

Internal Use

LCD control:	Toll and Balance (1)
Beeper Control:	4 Short Tones (1)
Low Battery:	OK (0)
Extended LED:	0
LED control:	0
R/W format:	Toll / Balance

Viewing HOT/HOV data for HOT and Feedback tags

HOT/HOV and Feedback tags contain additional data displayed on the HOV /HOT & FB page.

Prerequisites: None

1. Click on the **HOT /HOV & FB** tab to view the HOT /HOV & FB page.

Figure 3-10: HOT /HOV & FB Data Page

The screenshot shows a web interface for the 'HOT /HOV & FB' data page. It features two main panels: 'HOT /HOV and Feedback OBU Data' and 'Template Setting'. The 'HOT /HOV and Feedback OBU Data' panel contains a list of settings: HOV mode toggle (1), Feedback mode toggle (1), Audio feedback (No Change (0)), Visual feedback (No Change (0)), Current HOT/HOV switch state (HOV ON (1)), and Captured HOT/HOV switch state (TOLL (0)). The 'Template Setting' panel contains a single checkbox labeled 'Clear OBU Data', which is checked.

HOT /HOV and Feedback OBU Data	
HOV mode toggle:	1
Feedback mode toggle:	1
Audio feedback:	No Change (0)
Visual feedback:	No Change (0)
Current HOT/HOV switch state:	HOV ON (1)
Captured HOT/HOV switch state:	TOLL (0)

Template Setting
<input checked="" type="checkbox"/> Clear OBU Data

Printing the contents of the tag currently displayed

You can opt to print only the contents of the current tag data instead of printing a log file of past tag transactions.

Prerequisites: None.

1. Read or Program the tag whose data you wish to print.

NOTE: If the last action is a Read, the Read Tag Contents Report will be printed.
If the last action is a Write, the Write Tag Contents Report will be printed.

2. To preview the printout, select Tag → Print Preview.

3. To print the tag data, click on the printer icon button or select Tag → Print, then Select **Ok**. The page now prints.

Command and Controls

Command	How is this command executed?	Who can execute this command?	What does this command do?	What is the purpose of this command?
About TPS	select About TPS from Help menu	Users or Supervisors	opens About TPS window	can view the TPS software and TPS firmware versions currently installed
Add (custom Agency data fields)	select Design Agency Custom from Supervisor menu then, select Add from Custom Fields window	Supervisors	opens Add Field window	<ul style="list-style-type: none"> • can create a new Agency data field by specifying a field name, assigning a start bit and assigning a bit width • once custom fields have been created, values can be added to the fields
Add (custom Scratch Pad data fields)	select Design Scratchpad Custom from Supervisor menu then, select Add from Custom Fields window	Supervisors	opens Add Field window	<ul style="list-style-type: none"> • can create a new Scratch Pad data field by specifying a field name, assigning a start bit and assigning a bit width • once custom fields have been created, values can be added to the fields

T500 Tag Programming Station

Command	How is this command executed?	Who can execute this command?	What does this command do?	What is the purpose of this command?
Add (values for custom Agency data fields)	Select Design Agency Custom from Supervisor menu then, highlight field name and select Values in Custom Fields window then, select Add in Values window	Supervisors	opens Add Value window	can create a new value by specifying a value name and assigning a value
Add (values for custom Scratch Pad data fields)	select Design Scratchpad Custom from Supervisor menu then, highlight field name and select Values in Custom Fields window then, select Add in Values window	Supervisors	opens Add Value window	can create a new value by specifying a value name and assigning a value
Add User	select Users from Supervisor menu then, select Add User in Users window	Supervisors	opens Add User window	<ul style="list-style-type: none"> •can create Users or Supervisors by selecting the User Type and assigning a User ID •at least one Supervisor must be created during installation of TPS software.
Agency Name	select Configuration from Supervisor menu then, from Agency folder, type Agency name in Agency Name text box	Supervisors	sets Agency name	used by TPS software to display Agency name in title bar

T500 Tag Programming Station

Command	How is this command executed?	Who can execute this command?	What does this command do?	What is the purpose of this command?
Change (custom Agency data field)	select Design Agency Custom from Supervisor menu then, highlight field name and select Change in Custom Fields window	Supervisor	opens Change Field window	can change a custom Agency data field name, change the start bit or change the bit width
Change (custom Scratch Pad data field)	select Design Scratchpad Custom from Supervisor menu then, highlight field name and select Change in Custom Fields window	Supervisor	opens Change Field window	can change a custom Scratch Pad data field name, change the start bit or change the bit width
Change (values for custom Agency data field)	Select Design Agency Custom from Supervisor menu then, highlight field name and select Values in Custom Fields window then, highlight value name and select Change in Values window	Supervisor	opens Change Value window	can change a custom Agency value name or numeric value
Change (values for custom Scratch Pad data field)	Select Design Scratchpad Custom from Supervisor menu then, highlight field name and select Values in Custom Fields window then, highlight value name and select Change in Values window	Supervisor	opens Change Value window	can change a custom Scratch Pad value name or numeric value

T500 Tag Programming Station

Command	How is this command executed?	Who can execute this command?	What does this command do?	What is the purpose of this command?
Change Password	select Change Password from the User menu	Users and Supervisors	opens Change Password window	<ul style="list-style-type: none"> allows an operator to change their password operators should periodically change passwords for enhanced system security
Communications (Com Port, Baud Rate, Data Bits, Parity Type, Stop Bits)	select Configuration from Supervisor menu then, from Communications folder, select parameter from drop-down boxes	Supervisors	changes communication settings for serial communications with TPS computer	<ul style="list-style-type: none"> can select Com Port and other parameters being used by TPS computer only the Com Port setting should be changed by Supervisor, unless directed in writing by Kapsch TrafficCom
Configuration	select Configuration from Supervisor menu	Supervisors	opens TPS Configuration window	can view and change a variety of TPS software parameters
Delete (custom Agency data field)	Select Design Agency Custom from Supervisor menu then, highlight field name and select Delete in Custom Fields window	Supervisor	deletes custom Agency data field	can delete a custom Scratch Pad data field and all values for that field
Delete (custom Scratch Pad data field)	Select Design Scratchpad Custom from Supervisor menu then, highlight field name and select Delete in Custom Fields window	Supervisor	deletes custom Scratch Pad data field	can delete a custom Scratch Pad data field and all values for that field

T500 Tag Programming Station

Command	How is this command executed?	Who can execute this command?	What does this command do?	What is the purpose of this command?
Delete (value for custom Agency data field)	Select Design Agency Custom from Supervisor menu then, highlight field name and select Values in Custom Fields window then, highlight value name and select Delete in Values window	Supervisor	deletes value for custom Agency data field	can delete value from custom Agency data field
Delete (value for custom Scratch Pad data field)	Select Design Scratchpad Custom from Supervisor menu then, highlight field name and select Values in Custom Fields window then, highlight value name and select Delete in Values window	Supervisor	deletes value for custom Scratch Pad data field	can delete value from custom Scratch Pad data field
Delete User	select Users from Supervisor menu then, highlight user ID and select Delete User in Users window	Supervisors	deletes User or Supervisor	<ul style="list-style-type: none"> •can delete account for any employee who will no longer be using the TPS software •can delete the account of any operator who has forgotten their password. A supervisor can then recreate the account so a new password can be created

T500 Tag Programming Station

Command	How is this command executed?	Who can execute this command?	What does this command do?	What is the purpose of this command?
Design Agency Custom	select Design Agency Custom from Supervisor menu	Supervisors	opens Custom Fields window	can create, change or delete custom Agency data fields and choose to view custom values from Custom Fields window
Design Scratchpad Custom	select Design Scratchpad Custom from Supervisor menu	Supervisors	opens Custom Fields window	can create, change or delete custom Scratch Pad data fields and choose to view custom values from Custom Fields window
Diagnostic Window	select Diagnostic Window from Supervisor menu	Kapsch service personnel	opens Diagnostic window	used by Kapsch service personnel during troubleshooting
Diagnostic Window Password	select Configuration from Supervisor menu then, type password in Diagnostic Window Password text box	Kapsch service personnel	allows Diagnostic window to be displayed	used by Kapsch service personnel during troubleshooting
Enable Automatic Read	select Configuration from Supervisor menu then, from Automation folder, select Enable Automatic Read check box	Supervisors	enables automatic reading of tags	TPS automatically reads the tag when the AU drawer is closed with tag inside
Enable Automatic Write	select Configuration from Supervisor menu then, from Automation folder, select Enable Automatic Write check box	Supervisors	enables automatic programming of tags	TPS automatically programs the tag when Automatic Read is enabled and AU drawer is closed with tag inside
Enable logout timer	select Configuration from Supervisor menu then, from Logout Timer folder, select Enable logout timer check box	Supervisors	activates logout timer	TPS automatically logs operators out after system has been idle for time, in minutes, entered in the Logout Idle Time text box

T500 Tag Programming Station

Command	How is this command executed?	Who can execute this command?	What does this command do?	What is the purpose of this command?
Exit	select Exit from Supervisor menu	Supervisors	closes TPS software program	TPS software needs to be exited so the software can be relaunched in order to enter an authorization code
Help	press F1 key or, select Help Topics from Help menu or, click question mark button or, Select Help from pop-up windows	Users and Supervisors	opens Help window	<ul style="list-style-type: none"> provides basic help information for more extensive information, consult this manual
Load Template	select Load Template from User Menu	Users and Supervisors	opens Open window	can load a preexisting tag data configuration saved as a template for use in programming tags
Login	select Login from User menu	Users and Supervisors	allows an operator to log into the TPS system	can log in to system when all operators are logged out
Logout	select Logout from User menu	Users and Supervisors	allows an operator to log out of the TPS system	can log out after a shift or when a different user needs to log into the TPS system
Logout Idle Time	select Configuration from Supervisor menu then, from Logout Timer folder, type time (in minutes) in Logout Idle Time text box	Supervisors	sets the logout idle time	can set the length of idle time that will force a lockout when the logout timer is enabled

T500 Tag Programming Station

Command	How is this command executed?	Who can execute this command?	What does this command do?	What is the purpose of this command?
Print	select Print from Tag menu or, click printer button	Users and Supervisors	opens Print window	<ul style="list-style-type: none"> •if the last action performed was a read, the read data is printed •if the last action performed was a write, the write data is printed
Print Preview	select Print Preview from Tag menu	Users and Supervisors	displays print preview of page	shows how the tag data will be printed so print settings can be adjusted as necessary
Print Setup	select Print Setup from Tag menu	Users and Supervisors	opens Print Setup window	can make changes to print settings (paper size, source, orientation) before printing tag data
Program	click Program button or, select Program Tag from Tag menu	Users and Supervisors	writes data to tag	can program tag with data from a template
Read	click Read button or, select Read Tag from Tag menu	Users and Supervisors	reads data from tag	can view data stored in a tag
Save Template	select Save Template from Supervisor menu	Supervisors	opens Save As window	<ul style="list-style-type: none"> •allows Supervisor to save the current template data under an existing or new file name •any changes to the template data should be saved. Saving the data under a new file name creates a new template, while saving under an existing file name effectively modifies the existing template file.

T500 Tag Programming Station

Command	How is this command executed?	Who can execute this command?	What does this command do?	What is the purpose of this command?
Selected View Page	select Configuration from Supervisor menu then, from Default View Page folder, select page from Selected View Page drop-down box	Supervisors	sets default page that is displayed after a read or write	can select which page of information is displayed after a read or write
Serial Data Window	select Serial Data Window from Supervisor menu	Kapsch service personnel	opens Serial Data window	used by Kapsch service personnel during troubleshooting
Serial Data Window Password	select Configuration from Supervisor menu then, from Diagnostics folder, type password in Serial Data Window Password	Kapsch service personnel	allows Serial Data window to be displayed	used by Kapsch service personnel during troubleshooting
Unload Template	select Unload template from User menu	Users and Supervisors	immediately unloads template	<ul style="list-style-type: none"> •can clear the template data from the TPS software •users will not be able to program tags until another template is loaded
Users	select Users from Supervisor menu	Supervisors	opens Users window	<ul style="list-style-type: none"> •can view information about each user, such as when the last login was, and how often the user has read, programmed and commissioned tags. •can add or delete user or supervisor accounts from this window

T500 Tag Programming Station

Command	How is this command executed?	Who can execute this command?	What does this command do?	What is the purpose of this command?
Values (custom Agency data)	Select Design Agency Custom from Supervisor menu then, highlight field name and select Values in Custom Fields window	Supervisor	opens Values window	can add, change and delete values for custom data fields
Values (custom Scratch Pad data)	Select Design Scratch Pad Custom from Supervisor menu then, highlight field name and select Values in Custom Fields window	Supervisor	opens Values window	can add, change and delete values for custom data fields

MAINTENANCE PROCEDURES

4. THEORY OF OPERATION

TPS System overview

The TPS provides a method for Users and Supervisors to read and/or modify some of the data stored in the tags. The TPS is comprised of: a customer-supplied TPS Computer, a TPU and an AU. The customer-supplied TPS computer runs the TPS software that provides the UI and controls the TPU.

The TPU consists of:

- a Radio Frequency (RF) module
- a controller module, which provides the control of the RF signal to read and program tags and communicates with the TPS computer
- a power supply

Each TPU is configured when it leaves the factory with specific information including an authentication number and an agency ID. Each TPS is agency-specific to prevent one agency from overwriting another agency's data.

The AU houses:

- an antenna used to receive and transmit RF data to and from the tag
- an AU drawer used to position the tag for successful communication between the tag and the TPS. The drawer, when closed, contacts a switch which enables RF communications. If the drawer fails to make contact with the switch, the TPS will not be able to communicate with the tag. Remove the AU drawer to access this bolt and make adjustments as necessary.

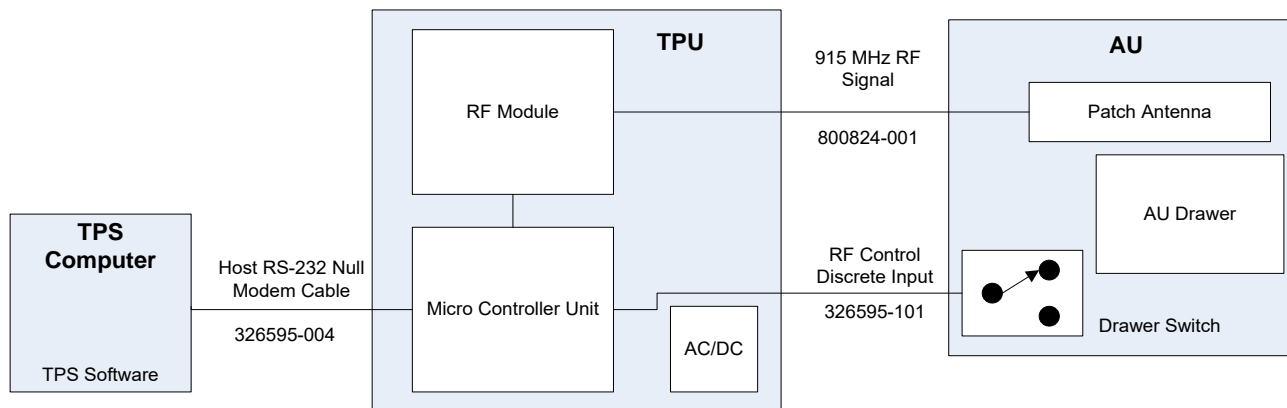

5. INSTALLATION

System component interconnections

NOTE: The two serial cables are not interchangeable. The TPU will not be able to communicate with the AU or TPS computer if these cables are swapped.

Table 5-1: TPS System Component Interconnections

Part No.	From	To	Description
326595-101	RF CONTROL port on TPU	RF CONTROL port on AU	straight through serial cable
326595-004	HOST PORT on TPU	serial port on customer-supplied computer	null modem serial cable
800824-001	RF OUT port on TPU	RF port on AU	RF cable
314922-004	120VAC power input on TPU	120VAC mains wall socket	AC power cable

Customer-Supplied TPS Computer requirements

The customer-supplied TPS Computer must be equipped with:

- a Microsoft Windows operating system: Windows XP, Windows 7, Windows 8 /8.1
- one available 9-pin serial port OR an available USB port and a USB-to-serial adapter that is supported by the operating system.
- a CD-ROM drive

Installing the TPS software

Only Supervisors should install the TPS software. To install the TPS software on the customer-supplied TPS computer, perform the following steps:

Prerequisites: You should be a Supervisor.

NOTE: The TPU does not have to be connected to the TPS computer during software installation.

1. Insert the TPS software CD in the TPS computer CD drive. Follow the instructions provided by the InstallShield Wizard. If InstallShield Wizard does not automatically launch, double-click **setup.exe** from the TPS software CD.

2. After the InstallShield Wizard welcome screen appears, select **Next** to proceed.

NOTE: Select **Cancel** to exit the installation at any time.

3. After reviewing the license agreement, select **I accept the terms in the license agreement**. Select **Next** to proceed.

4. Review the **Readme Information**. Select **Next** to proceed.

5. Enter a user name and organization name in the appropriate text boxes. The default user name and organization are shown. Note that this user name and organization name are not used by the TPS software and is for installation purposes only.

6. Under **Install this application for**, select **Anyone who uses this computer** so the TPS software can be accessed by all users. Select **Next** to proceed.

7. Select the destination folder where the software will be installed. Select **Next** to proceed.

NOTE: Instead of using the default folder
C:\Program Files (x86)\Kapsch TrafficCom IVHS\T500 Tag Programmer <version>,
select **C:\Users\myUserName\Kapsch TrafficCom IVHS\T500 Tag Programmer <version>**
in order to have full control (read / write) permissions of folder & files.

8. Review the installation settings. Select **Back** to return to the previous installation steps and make changes as needed. Select **Install** to begin installation.

NOTE: A shortcut icon  to launch the program is created on the desktop when installation is complete.

9. After the installation is completed, click **Finish** to exit InstallShield Wizard.

Constraints:

Following notes are only applied to Windows Vista and above, and the installation folder is under C:\Program Files (x86).

Due to security feature User Account Control (UAC) introduced since Windows Vista, any non-Administrator program that tries to write to protected locations such as "Program Files" will get their writes caught and redirected to an alternative location, Virtual Store.

T500 Tag Programming Station

Most programs in Windows including T500 do not run as an administrator even if you are signed into an admin account.

In our case, if T500 attempts to write to files in installation folder eg. "C:\Program Files (x86)\Kapsch TrafficCom IVHS\T500 Tag Programmer 1.12.04.16", such as template files and log files, the write will get redirected to "C:\Users\username\AppData\Local\VirtualStore\Program Files (x86)\Kapsch TrafficCom IVHS\T500 Tag Programmer 1.12.04.16".

To avoid triggering the use of Windows Virtual Store, run T500 PC software as Administrator by right-clicking the executable TPS.exe and select **Run as administrator** option. If necessary, use **Windows Explorer** to copy the agency mapping file TPSCfg.xml to the T500 installation folder in C:\Program Files (x86).

Installing /Upgrading the agency mapping file

The agency mapping file TPSCfg.xml included in the supplied CR-ROM /software package is installed when installing the T500 software.

To install updates on the agency mapping file provided by Kapsch TrafficCom (see constraints in page 47), follow these steps.

1. Use **Windows Explorer** to copy the agency mapping file **TPSCfg.xml** into the folder created in Installing the T500 software on page 47.
2. Launch the T500 software by right-clicking the executable **TPS.exe** and select **Run as administrator** option to have the new mapping file take effect.

Note: User is advised NOT to modify the agency mapping file. Incorrect settings may cause improper function of the T500 Tag Programming Station. Contact Kapsch TrafficCom for new update on the file.

Launching the TPS software for the first time

The first time you launch the TPS software, you must log in using the installer password and then create a Supervisor account.

NOTE: The **User ID** and **Password** are case-sensitive.



1. Launch TPS software by right-clicking the icon  or the executable TPS.exe and select **Run as administrator** option.
2. Once the Login dialog box appears after starting and authenticating the TPS software, type 'installer' in the **User ID** text box and type 'doinstall' in the **Password** text box. Select **OK**.
3. The message "You must add a supervisor to the user database" appears. At least one Supervisor must now be created before the TPS software can be run. Proceed to Creating a new User or Supervisor, page 59.

Setting the logout timer

The Logout Timer automatically logs the operator out of the TPS software after the system has been idle for a preset time. When the logout timer enforces a logout, the **Forced Logout** message appears at the bottom of the main screen. Log in to continue using the TPS Software.

Prerequisites: You must be logged in as a Supervisor.

1. Select Supervisor → Configuration. The TPS Configuration window appears.
2. From the TPS Configuration window, select the **Logout Timer** tab.
3. To enable the logout timer, select the **Enable logout timer** check box.
4. Enter the Logout Idle Time by typing a value, in minutes, between 1 and 180. The default Logout Idle Time is 30 minutes. Select **Apply** or **OK** to make changes.

Entering the Agency name

The Agency parameter is used to determine how the Agency name is displayed in the TPS software title bar.

Prerequisites: You must be logged in as a Supervisor.

1. Select Supervisor → Configuration. The TPS Configuration window appears.
2. Select the Agency tab.
3. Type the agency name in the **Agency Name** text box. Select **Apply** or **OK** to make changes.
4. The agency name is now displayed in the title bar (in this case, the agency name is **Agency**).

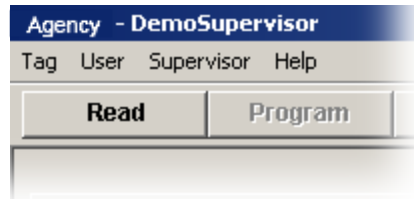

Setting the communications parameters

The communications parameters identify the settings of the customer-supplied computer serial port used to communicate with the TPU.

Prerequisites: You must be logged in as a Supervisor.

1. Select Supervisor → Configuration. The TPS Configuration window appears.

Figure 5-1: TPS Configuration Window

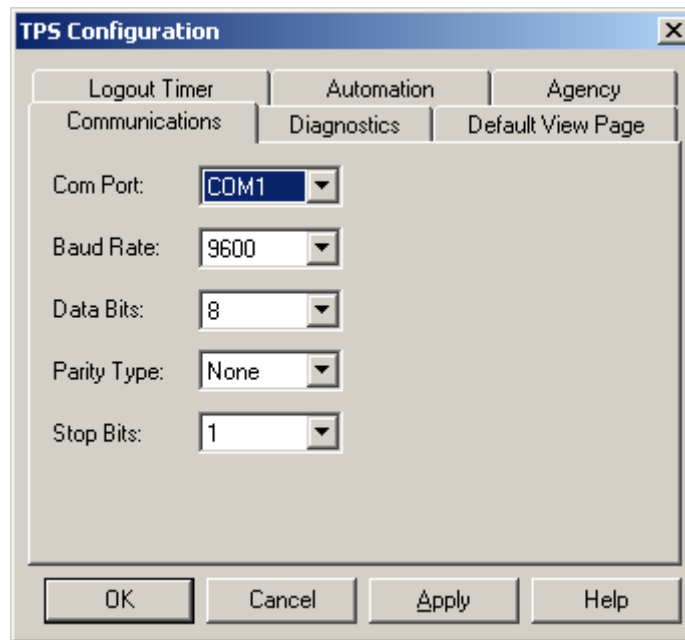

2. From the Com Port drop-down box, select the computer serial port that the TPU connects to.

3. The Baud Rate, Data Bits, Parity Type and Stop Bits default values are shown in Figure 5-1. Do not change these parameters without written authorization from Kapsch TrafficCom. See Communication error, page 53 to resolve any communication errors.

Setting automatic tag reading

When automatic tag reading is enabled, the T500 attempts to read the tag in the AU drawer whenever the T500 detects the AU drawer has been closed.

Prerequisites: You must be logged in as a Supervisor.

1. Select Supervisor → Configuration. The TPS Configuration window appears.
2. Select the Automation tab.
3. Select the **Enable Automatic Read** check box. Select **Apply** or **OK** to make changes.
4. The T500 now automatically reads the tag in the AU drawer whenever T500 detects the AU drawer has been closed.

Setting automatic tag writing

When automatic tag writing is enabled, the T500 attempts to write to the tag after the tag has been successfully automatically read.

Prerequisites: You must be logged in as a Supervisor.

	CAUTION:
Tag data is automatically overwritten when the Automatic write enabled message is displayed. Ensure you want the current template data written to the tag before closing the AU drawer.	

1. Select Supervisor → Configuration. The TPS Configuration window appears.
2. Select the Automation tab.
3. Select the **Enable Automatic Write** check box. Select **Apply** or **OK** to make changes.
4. The T500 now automatically programs the tag in the AU drawer once the tag has been automatically read successfully.

Setting the default view page

Set the default view page to set which page of tag information appears after a tag read or write.

Prerequisites: You must be logged in as a Supervisor.

1. Select Supervisor → Configuration. The TPS Configuration window appears.
2. Select the Default View Page tab.
3. Select the desired default page from the **Selected View Page** drop-down box.

Note: The Toll/Balance default page option is only available for Toll/Balance tags.

6. TROUBLESHOOTING

Diagnostics

The Diagnostics feature of the T500 software is for use by Kapsch TrafficCom service personnel.

The password on the Diagnostics tab are for use by Kapsch TrafficCom personnel only.

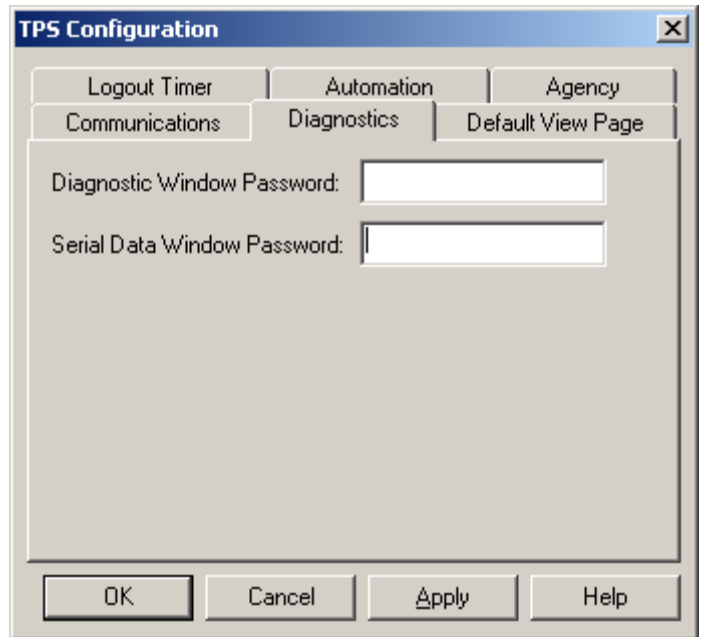

Viewing the software and firmware versions

Prerequisites: None.

1. Select Help → About TPS.
2. The **About TPS** window appears, displaying the software and firmware version.
3. Select **Ok** to close the window.

Communication error

When communications fail between the TPU and the customer-supplied computer, the following error message appears:

Figure 6-1: Communication Problem between TPU and Customer-Supplied Computer



To resolve this error:

1. Verify that the TPU is turned on and is connected to the host computer. Check the TPU Status at the bottom right of the TPS computer screen.

Figure 6-2: TPU status – not connected to customer-supplied computer

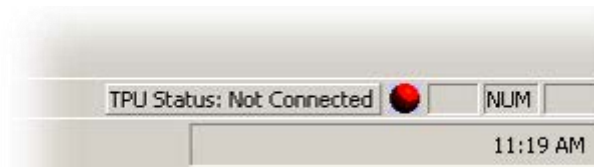

Figure 6-3: TP status – connected to customer-supplied computer



NOTE: Cable 326595-001 connects the TPU to the AU. Cable 326595-002 connects the TPU to the customer-supplied computer. These two serial cables are not interchangeable. The TPU will not be able to communicate with the AU or customer-supplied computer if these cables are swapped.

2. Verify all cable connections between the TPU and the TPS computer and between the TPS and the AU (see System component interconnections, page 46).
3. Verify that the TPS computer serial port settings match the settings in the TPS software (see Setting the communications parameters, page 50).

Authentication error

An Authentication Error message (Figure 6-4) occurs when the authentication code entered during software initialization (see Authenticating the TPS software, page 20) does not match the TPU. Each TPU has its own unique Authentication code and cannot be connected to a different TPS computer without providing the TPS computer with the correct Authentication code.

Figure 6-4: Authentication Error Message

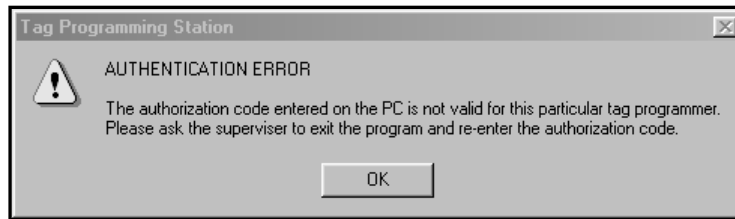

To resolve this error:

Prerequisites: You must be logged in as a supervisor to exit the program.

1. Exit the T500 software (see Exiting the TPS software, page 21).
2. Launch the T500 software to re-enter the Authentication code again.

Login error

A login error message (Figure 6-5) occurs when either the user ID or password entered does not match known user information. Both the user ID and password are case-sensitive.

Figure 6-5: Login Error Message

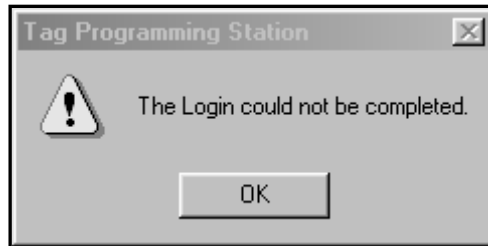

To resolve this error:

- 1.Reenter your user ID and password.
- 2.If the error persists, get someone to log in as a Supervisor to confirm the user ID exists.

Configuration error

A configuration error message refers to a difference in the configuration data stored in the TPU versus the data stored in the customer-supplied TPS computer. Contact the Kapsch service department to resolve this error.

Read Failed Error

A Read Failed error (see Figure 6-6) is generated when the TPU fails to read a tag. The Read Failed error includes a failure message that provides an indication of the specific type of read failure. Check Table 6-1 for a list of possible causes and solutions for your specific error. Select **Details** to view additional error information (see Figure 6-7) for the failure. These details may be request by Kapsch TrafficCom to aid in troubleshooting.

Figure 6-6: Read Failed Error Message



Figure 6-7: Typical Read Error Message Details

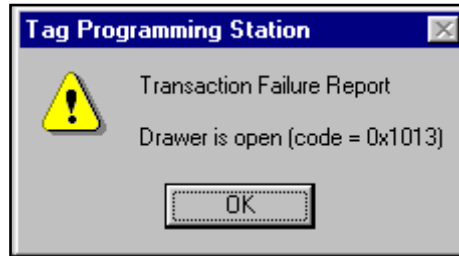

Table 6-1: Read Errors, Causes, and Solutions

Read Failure Error Messages		
Failure Message	Possible Causes	Solution
Could not read tag after multiple attempts	Tag is not orientated correctly in AU Drawer	check placement of tag in AU drawer
	Non-operational tag	Replace tag
	Non-operational TPU	Contact Kapsch service department
Drawer is open	Drawer not fully closed	Ensure drawer is closed and retry read
	Drawer Switch needs adjusted	remove drawer from AU and adjust bolt at back of

T500 Tag Programming Station

Read Failure Error Messages		
		drawer as required
	Drawer Switch failure	Contact Kapsch service department
Authentication Error	TPU has been swapped without updating the TPS authentication.	exit and relaunch the software to enter the TPS authentication code
Configuration Error	TPU battery has failed (older units only)	Contact Kapsch service department

Write Failed Error

A Write Failed error (see Figure 6-8) is generated when the TPU fails to program a tag. The Write Failed error includes a failure message that provides an indication of the specific type of write failure. Check Table 6-2 for a list of possible causes and solutions for your specific error. Select **Details** to view additional error information (see Figure 6-9). These details may be request by Kapsch TrafficCom to aid in troubleshooting.

Figure 6-8: Write Failed Error Message



Figure 6-9: Typical Write Error Message Details

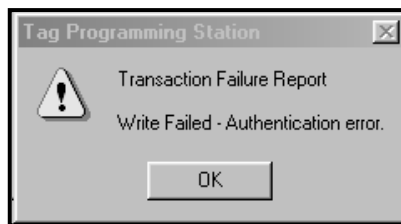

T500 Tag Programming Station

Table 6-2: Write Errors, Causes, and Solutions

Read Failure Error Messages		
Failure Message	Possible Causes	Solution
Agency Not Supported	The tag has a different Agency ID	confirm Agency ID is correct
Tag ID Specified is different than last read	Attempting to program the tag without having first read the tag.	read tag, then retry write
Could not read tag after multiple attempts	Tag is not orientated correctly in AU Drawer	check placement of tag in AU drawer
	Non-operational tag	Replace tag
	Non-operational TPU	Contact Kapsch service department
Drawer is open	Drawer not fully closed	Ensure drawer is closed and retry read
	Drawer Switch needs adjusted	remove drawer from AU and adjust bolt at back of drawer as required
	Drawer Switch failure	Contact Kapsch service department
Authentication Error	TPU has been swapped without updating the TPS authentication.	exit and relaunch the software to enter the TPS authentication code

7. MAINTENANCE PROCEDURES

This section outlines procedures for maintaining the T500 system software for normal operation. For hardware failures, return failed equipment to Kapsch TrafficCom for service.

Creating a new User or Supervisor

Prerequisites: You must be logged in as a Supervisor.

1. Select Supervisor → Users.
2. Select **Add User** from the **Users** window.
3. Select the type of operator (either **User** or **Supervisor**) to be created from the **User Type** drop-down box.
4. Type the operator's user ID in the **User ID** text box and select **OK**.
5. The **Users** window now lists the new operator. Select **Close** to exit the **Users** window.

NOTE : All new users added to the list must create a password before using the TPS software (see Creating a password, page 22).

Deleting a User or Supervisor

Prerequisites: You must be logged in as a Supervisor.

1. Select Supervisor → Users.
2. Select the User or Supervisor to be deleted.
3. Select Delete User.
4. The User or Supervisor is now removed from the **Users** window. Select **Close** to exit the **Users** window.

Creating/Modifying a template file

Templates contain standardized data that you can use to program multiple tags of a type with the same data. Template data includes four common areas for all tag types: **Factory/Agency**, **Agency(Custom)**, **Scratch Pad**, **Scratch Pad (Custom)**. Some tag types have specific template data. The following sections outline how to create or change template data.

Prerequisites:

- You must be logged on as a Supervisor.
- You must first read a tag in order to display all the data fields on screen.

NOTE: A template is designed for one tag type only.
Try to program a tag of different type will generate error.

To create a new template:

1. First read a tag of the type that the new template is intended for (see Reading tags, page 23), to initially populate the data fields. Make sure that no template file is open.
2. Edit Factory/Agency area (see Changing Factory/Agency data , page 61)
3. Edit Agency(Custom) area to create data fields and define field values (see Changing custom Agency data , page 62)
4. Edit Scratch Pad area (see Changing Scratch Pad data , page 71)
5. Edit Scratch Pad (Custom) area to create data fields and define field values (see Changing custom Scratch Pad data, page 72)
6. Edit Toll/Balance area if the template is for Toll/Balance tags (see Changing Toll/Balance data , page 75).
7. Edit HOT/HOV & FB area if the template is for HOT /HOV and Feedback tags (see Changing HOT/HOV & FB data , page 76).
8. Save the template file.

To modify a template:

1. First read a tag of the same tag type as the template file to be loaded (see Reading tags, page 23) to show all the data fields.
2. Load an existing template file (see Loading a template , page 25).
3. Modify the four areas: Factory/Agency, Agency(Custom), Scratch Pad, Scratch Pad (Custom).
4. Save the template file.

Changing Factory/Agency data

NOTE: The Vehicle reference data is the decimal value of the binary code representing the first four Agency fields (**Vehicle Type**, **Vehicle Axles**, **Vehicle Weight**, and **Vehicle Rear Tires**). Change in any of the four Agency fields will automatically update the Vehicle reference data which is used as a reference only.

1. In the following example, an OBU tag is read and the tag data acts as a baseline in creating a template.
2. Select new template values from the drop-down boxes in the **Template Data** area.

Figure 7-1: Factory /Agency page

The screenshot shows the 'Factory/Agency' page in the Kapsch - DemoSupervisor application. The page is divided into several sections:

- Factory:**
 - Tag Type: Interior OBU / FPT (0)
 - Application ID: Toll Collection (1)
 - Group ID: Kapsch (65)
 - Agency ID: Kapsch (0)
 - Serial Number: 16777214
- Agency (Current data read from a tag):**
 - Vehicle Reference: 72
 - Vehicle Type: Automobile (1)
 - Vehicle Axles: 2 Axles (2)
 - Vehicle Weight: <= 7000 lbs. (0)
 - Vehicle Rear Tires: Single Rear Tires (0)
 - Revenue Type: Private Vehicle (0)
 - Commission: Commissioned (0)
 - Mounting Location: Windshield (0)
- Template Data (New tag data selected for a template):**
 - 201
 - Pickup Truck (3)
 - Not Changed
 - Not Changed
 - Dual Rear Tires (1)
 - Commercial Vehicle (1)
 - Not Changed
 - Not Changed

At the bottom of the page, there is a 'Template File' section with a grid of blue squares representing a barcode or data matrix.

Changing custom Agency data

NOTE: The **Clear Unassigned Bits** checkbox should always be enabled.

1. Go to **Agency (Custom)** page to continue editing of a template.
2. Select menu **Supervisor**→**Design Agency Custom**, a **Custom Fields** dialog appears for you to add or modify data fields.
3. To add a new Agency data field, see section “Creating custom Agency data field” on page 63.
4. To modify a custom Agency data field, select the data field and click **Change** button.
5. To remove a custom Agency data field, select the data field and click **Delete** button.

Figure 7-2: Agency (Custom) page

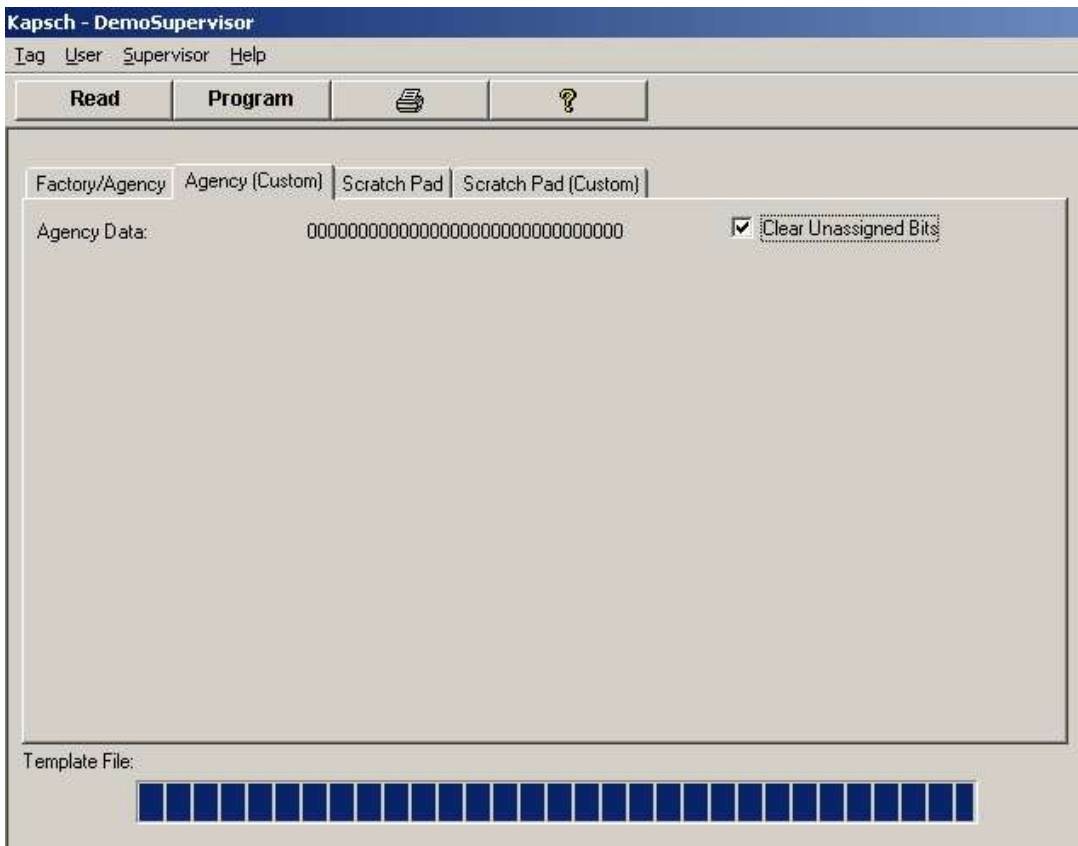

Creating custom Agency data field

A supervisor must first create a data field, and then create the available values for the data field. These values will then be available for selection via a drop-down box on the **Agency (Custom)** page. The custom Agency data is represented by a 31-bit binary code for standard tags and a 7-bit binary code for toll/balance tags. This binary code is displayed at the top of the Agency (Custom) page.

A maximum of 10 custom agency data fields can be created. In the example used in this procedure we will create the custom data fields and values in Table 7-1:

Table 7-1: Data Fields and Values (used in task example)

Data Field Name	Value Names	Values
Fleet	Undefined	0
	VehicleA	1
	VehicleB	2
	VehicleC	3
Taxi	Undefined	0
	CompanyA	1
	CompanyB	2
	CompanyC	3
	CompanyD	4

1. To create a custom Agency data field, select menu **Supervisor** → **Design Agency Custom**, the **Custom Fields** dialog box appears.

Figure 7-3: Custom Fields dialog

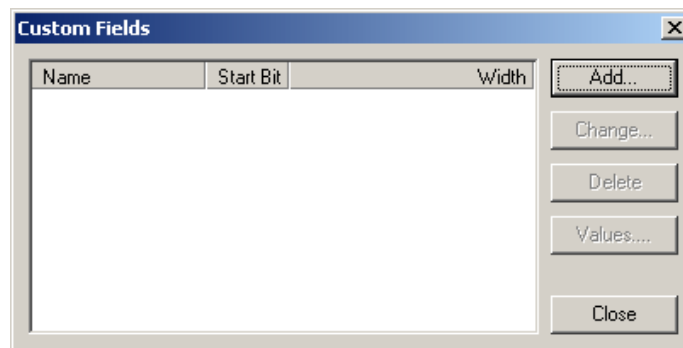

2. From the **Custom Fields** dialog box, click **Add** button. The **Add Field** dialog box appears.

NOTE: The data field name is limited to 25 characters

3. From the **Add Field** dialog box, type the name of the first data field (in this case, 'Fleet') in the **Name** text box.

NOTE: The default **Start Bit** value should be used to simplify the process of creating an Agency data field. The default Bit Width indicates the remaining size that can be used. Set the width according to the size of a data field.

Figure 7-4: Add Field dialog



4. In the **Add Field** dialog box: Leave the **Start Bit** value of 65 unchanged.

Working from left to right, the initial default Start Bit is 65 for both standard and toll/balance tags, and the maximum Bit Width is 31 and 7 respectively. Following diagrams show how the agency data will look like.

Figure 7-5: Start Bit for First Custom Agency data field (for Standard Tags)

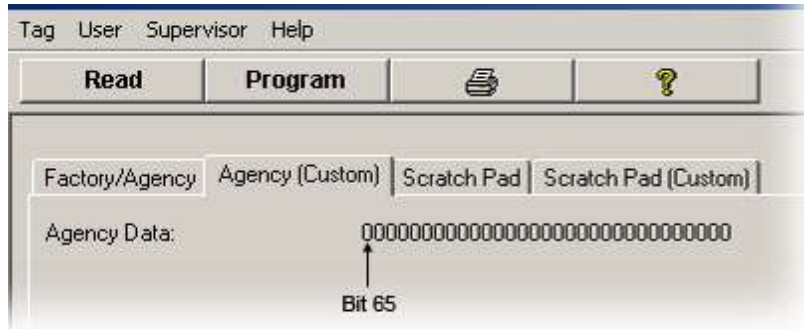

Figure 7-6: Start Bit for First Custom Agency data field (for Toll/Balance Tags)



T500 Tag Programming Station

5. Determine the Bit Width required to accommodate the maximum value of the custom data field. Looking back at Table 7-1:, we see the Fleet data field will have a maximum value of 3, representing VehicleC.

As is shown in Table 7-2, a data field with a maximum value of 3 requires a bit width of 2.

Table 7-2: Bit Width of Values

Maximum Value of Data Field	Bit Width
1	1
2-3	2
4-7	3
8-15	4
16-31	5
32-63	6

6. In the **Add Field** dialog box: Type number of bits in the Bit Width text box. In this example, the maximum value is 3, so a bit width of 2 is required.

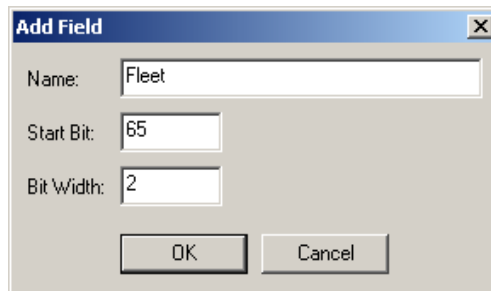

7. Select **OK** to create the new Field. The new Fleet field is now displayed in the **Custom Fields** window.

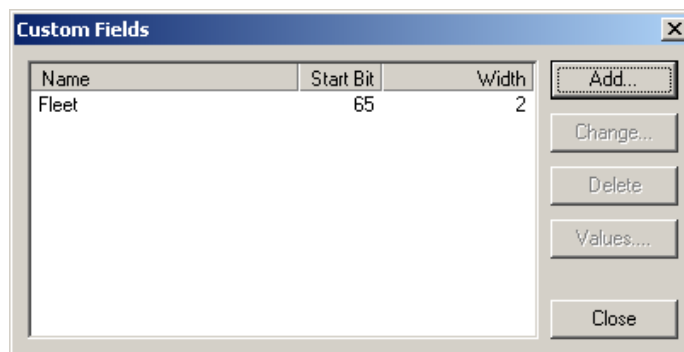

T500 Tag Programming Station

8. To begin creating the next data field, in this case, Taxi, click **Add** button from the **Custom Fields** window. The **Add Field** dialog box appears.
9. Type a field name (in this case, 'Taxi') in the **Name** text box.
10. In the **Add Field** dialog box: Leave the **Start Bit** value of 67 unchanged.
Working from left to right, the default Start Bit is now 67 because in this example, bits 65 and 66 were reserved for the Fleet data which has a Bit Width of 2.

Figure 7-7: Example of Start Bit for Second Custom Agency data field (for Standard Tags)



11. Referring to Table 7-2 on page 65, determine the bit width required for the data field by determining what the maximum value will be. In our example, the Taxi data field with a maximum value of 4 requires a bit width of 3.
12. In the **Add Field** dialog box: Type the Bit Width, in this case '3', in the Bit Width text box. Select **Ok**.
The binary Agency data code will now have 5 bits reserved for the Fleet and Taxi data fields. The remaining 25 bits are unassigned.

Figure 7-8: Example of Reserved Bit for Second Custom Agency data field (for Standard Tags)

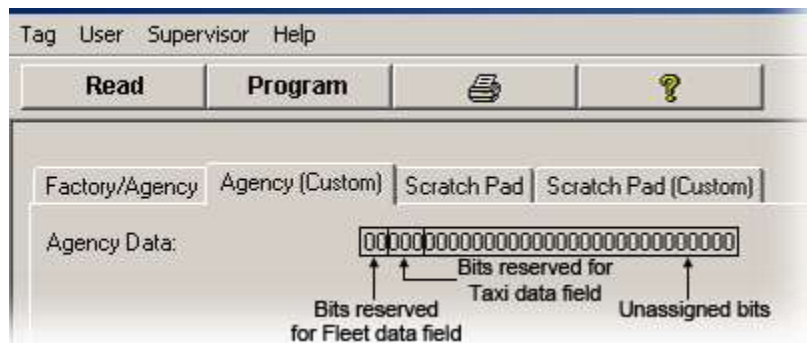

Creating values for an Agency data field

1. Select menu **Supervisor**→**Design Agency Custom**. From the **Custom Fields** window, select the Agency data field name which requires new Values. Click **Values** button. The **Values** window appears.

Figure 7-9: Custom Fields dialog box with added data fields

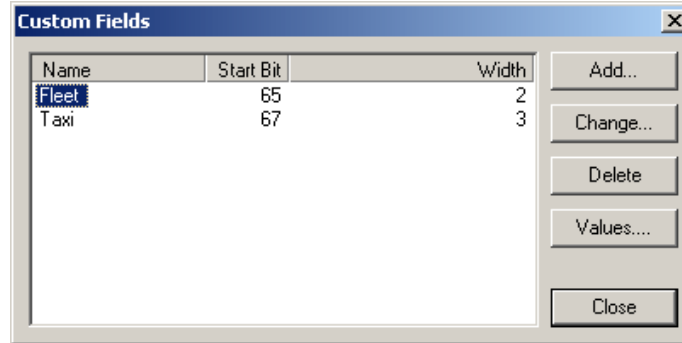

2. In the **Values** window, click **Add** button to define values.

Figure 7-10: Values Window of data field

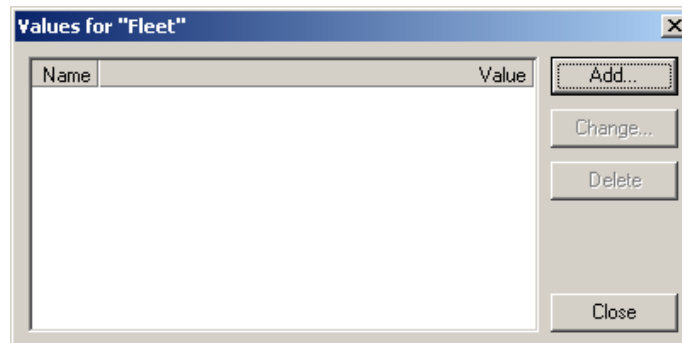

3. Type the name of the value in the **Name** text box.

Figure 7-11: Add Value dialog

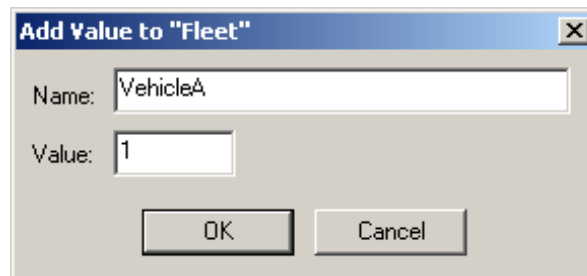

T500 Tag Programming Station

4. Enter a unique numeric value in the **Value** text box. Select **OK** to create the value.

NOTE: Each value must be unique. An error message appears if an attempt is made to create duplicate values.

NOTE: If a value is entered that is too large for the Bit Width specified, a message will be displayed showing the range of values available for the data field's Bit Width. The Bit Width must be increased to accommodate values outside the available value range.

5. The new value name and value are displayed in the **Values** window. Repeat steps 1 through 4 until all value names and values have been created for the data field.

Figure 7-12: Values window with added values

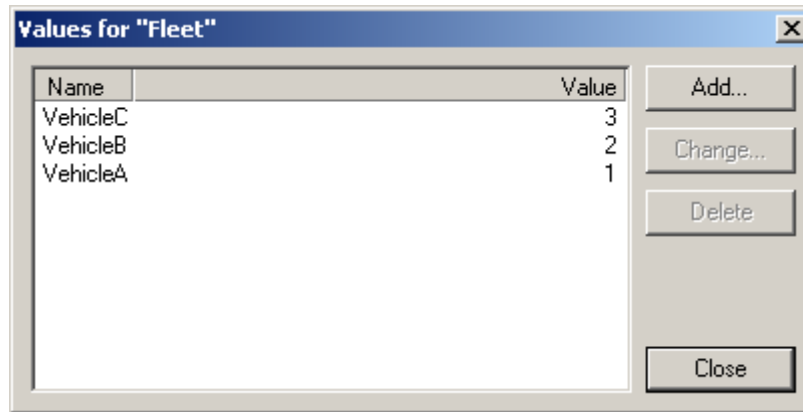

6. To change any value name or value, select the value to highlight it, and then select **Change**. To delete a value, select the value to highlight it, and then select **Delete**. Select **Close** to exit the **Values** window.

7. Repeat step 1 through 6 to set values to all data fields.

8. Once finish and close the **Custom Fields** dialog, the **Agency(Custom)** page will show all the data fields.

9. In the template area on the right-hand side, select value for each data field from the drop-down box. Any unassigned value of a data field will be automatically named as "Undefined".

Figure 7-13: Custom Agency Data Available for Selection

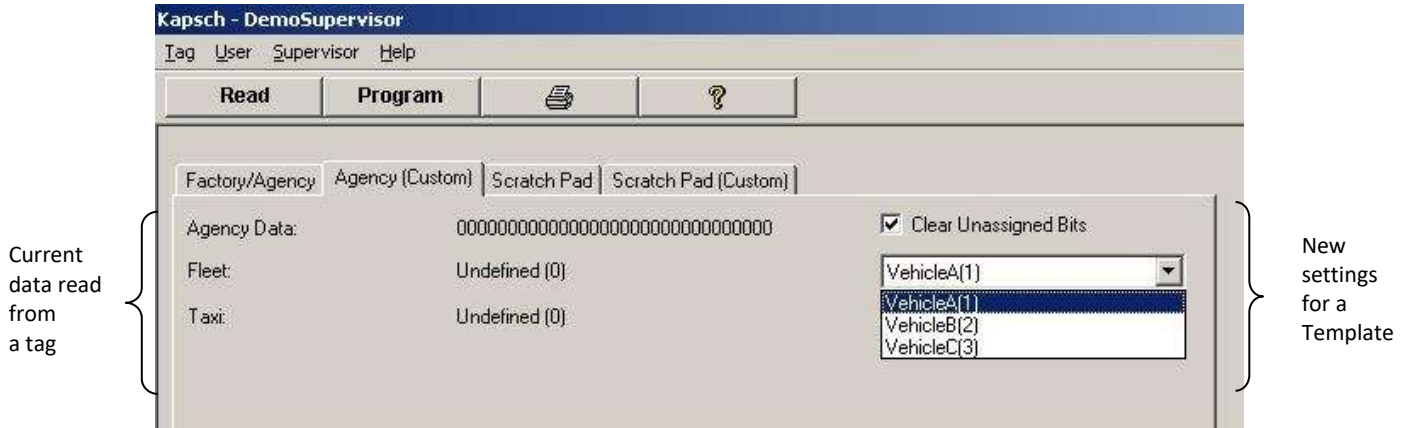

10. Go to Scratch Pad tab to continue template editing or save template and program a tag, the Agency (Custom) page will show the programmed field data in tag.

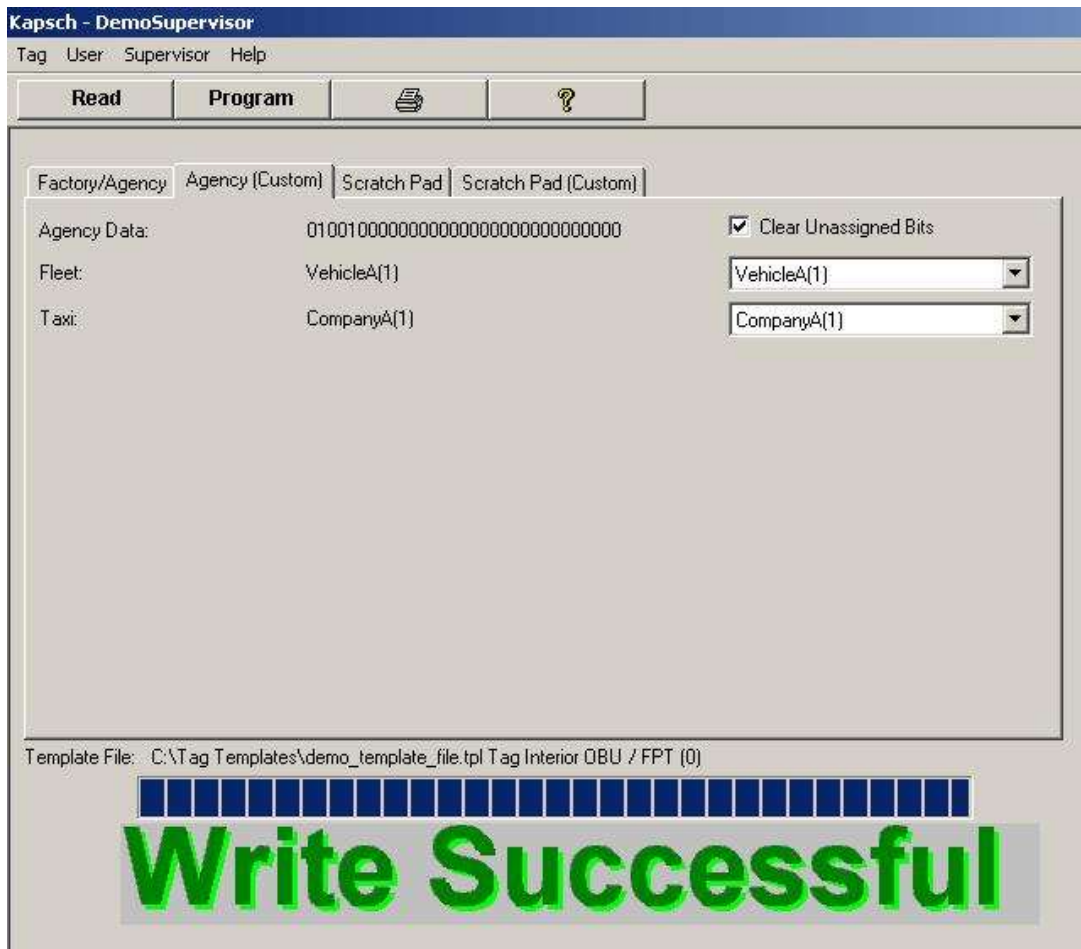

Figure 7-14: Programmed Custom Agency Data



Deleting a custom Agency data field

Prerequisites: You must be logged on as a Supervisor.

1. Select menu **Supervisor** → **Design Agency Custom**.
2. From the **Custom Fields** window, select the custom Agency data field to be deleted.
3. Click **Delete** button to remove data field.

Changing Scratch Pad data

1. Go to the **Scratch Pad** page to continue editing of a template .
2. The Scratch Pad data displays data gathered from a toll plaza reader. Select the **Clear Traffic management Data** and **Clear Toll Collection Data** check boxes to set all values to 0.

Figure 7-15: Scratch Pad page

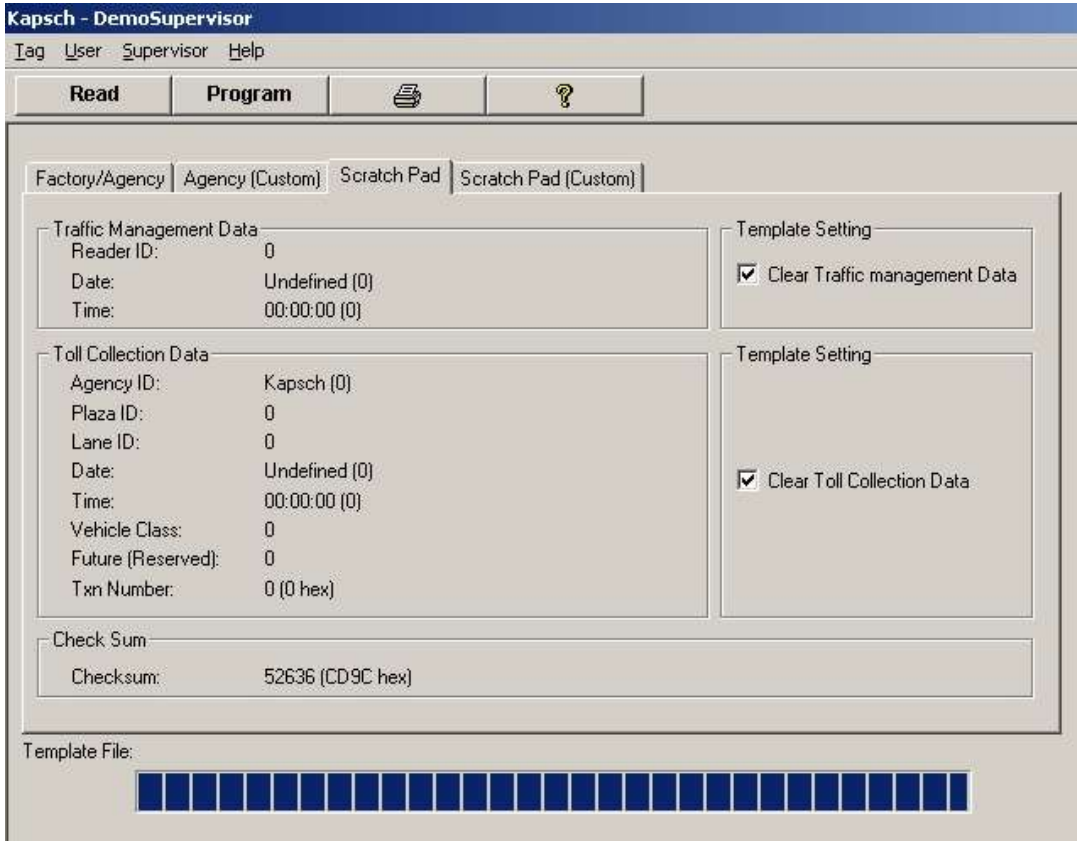

Changing custom Scratch Pad data

1. Go to **Scratch Pad (Custom)** page to continue editing of a template.
2. Select menu **Supervisor** → **Design Scratchpad Custom**, a **Custom Fields** dialog appears for you to add or modify data fields.
3. To add a new Scratch Pad data field, see section “Creating custom Scratch Pad data field” on page 73.
4. To modify a custom Scratch Pad data field, select the data field and click **Change** button.
5. To remove a Scratch Pad data field, select the data field and click **Delete** button.

NOTE: **Clear Unassigned Bits** should always be enabled.

Figure 7-16: Scratch Pad (Custom) page

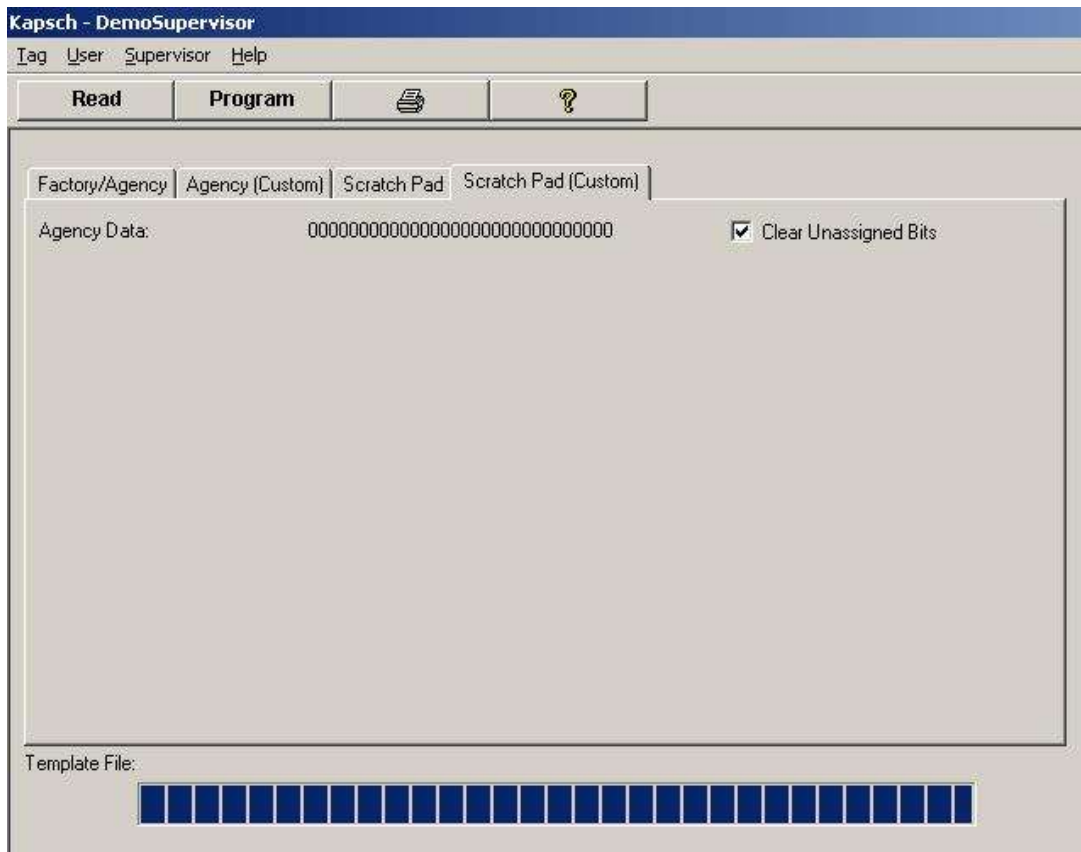

Creating custom Scratch Pad data field

The supervisor must first create a data field, and then create the values for the field. These values will then be available for selection via a drop-down box on the **Scratch Pad (Custom)** page. The custom Scratch Pad data is represented by a 30-bit binary code for standard tags and a 4-bit binary code for toll balance tags. This binary code is displayed at the top of the Scratch Pad (Custom) page.

A maximum of 10 custom scratch pad data field can be created.

Prerequisites: You must be logged on as a Supervisor.

1. Select menu **Supervisor** → **Design Scratchpad Custom**.

2. Create custom Scratch Pad data, follow the procedure for creating custom Agency data (see Creating custom Agency data, page 63), keeping in mind the following differences:

- For standard tag, the custom Scratch Pad binary code is 30 bits long, starts at bit 194 (see Figure 7-17, page 73).
- For toll/balance tag, the custom Scratch Pad binary code is 4 bits long, starts at bit 72 (see Figure 7-18, page 73).
- For HOT and Feedback tags, the custom Scratch Pad binary code is 24 bits long and starts at bit 200.

Figure 7-17: Standard custom Scratch Pad data

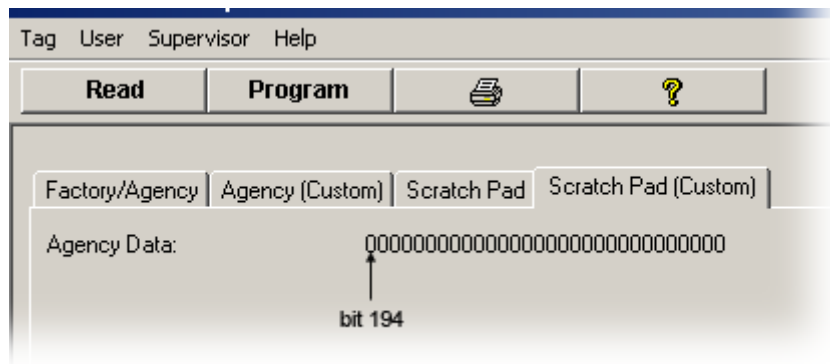
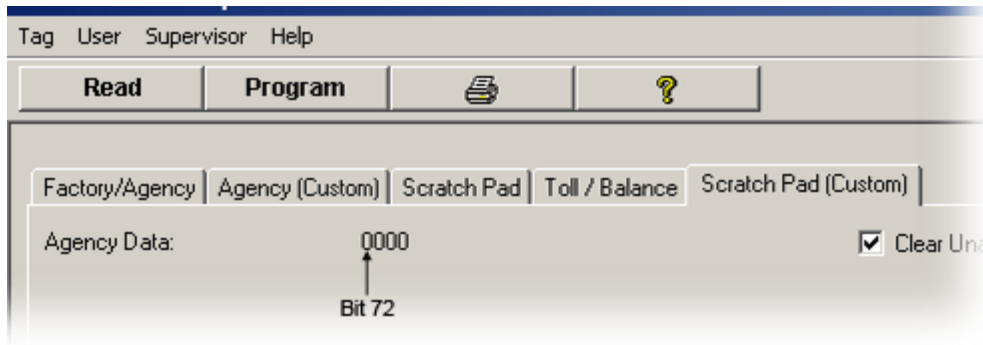

Figure 7-18: Toll/Balance custom Scratch Pad data



Deleting a custom Scratch Pad data field

Prerequisites: You must be logged on as a Supervisor.

1. Select menu **Supervisor**→**Design Scratchpad Custom**.
2. Select the custom Scratchpad data field to be deleted.
3. From the **Custom Fields** window, select **Delete**. The data field is deleted.

Changing Toll/Balance data

The Toll/Balance page displays the Toll/Balance data for Toll/Balance tags.

1. Go to the **Toll/Balance** page to continue editing of a template if the template is for Toll/Balance tags.
2. To clear the Balance and set the value to zero, select “Clear” from the Balance drop down box.
3. To change the Balance: Select “Specific” from the Balance drop-down box.
4. Enter a value between \$0.00 and \$3276.75 in \$0.05 increments in the \$ text box. Select any of the drop-down boxes on the Toll/Balance page to apply changes.
5. If a value outside of this range is entered or the value is not in \$0.05 increments, the error message “Balance is Invalid (Range from: \$0.0 to \$3276.75. Increments of 0.05)” will appear.
6. Make any other changes by selecting the desired parameter from the appropriate drop-down box.

Figure 7-19: Toll/Balance page

The screenshot shows the 'Toll / Balance' page in the Kapsch software. The page is divided into two main sections: 'Toll Information' and 'Internal Use'. The 'Toll Information' section contains fields for Toll Amount, Balance, Low Balance, Balance Adjust ID, and Balance Adjust Date. The Balance field is currently set to \$0.00, but the 'Specific' dropdown menu is selected, and a text box next to it shows a new value of \$50.00. The 'Internal Use' section contains fields for LCD control, Beeper Control, Low Battery, Extended LED, LED control, and R/W format. A 'Template File' field is located at the bottom of the page.

Annotations on the screenshot:

- A bracket on the left side of the 'Toll Information' section is labeled "Current data read from a tag".
- A bracket on the right side of the 'Toll Information' section is labeled "New settings for a Template".

Changing HOT/HOV & FB data

The HOT /HOV & FB page displays the state of HOT /HOV and Feedback tag.

1. Go to the **HOT /HOV & FB** page to continue editing of a template if the template is for HOT /HOV and Feedback tag.
2. Select Clear OBU Data to set all values to 0 except Current HOT/HOV switch state which reflects the hardware switch position of a tag.

Figure 7-20: HOT /HOV & FB page

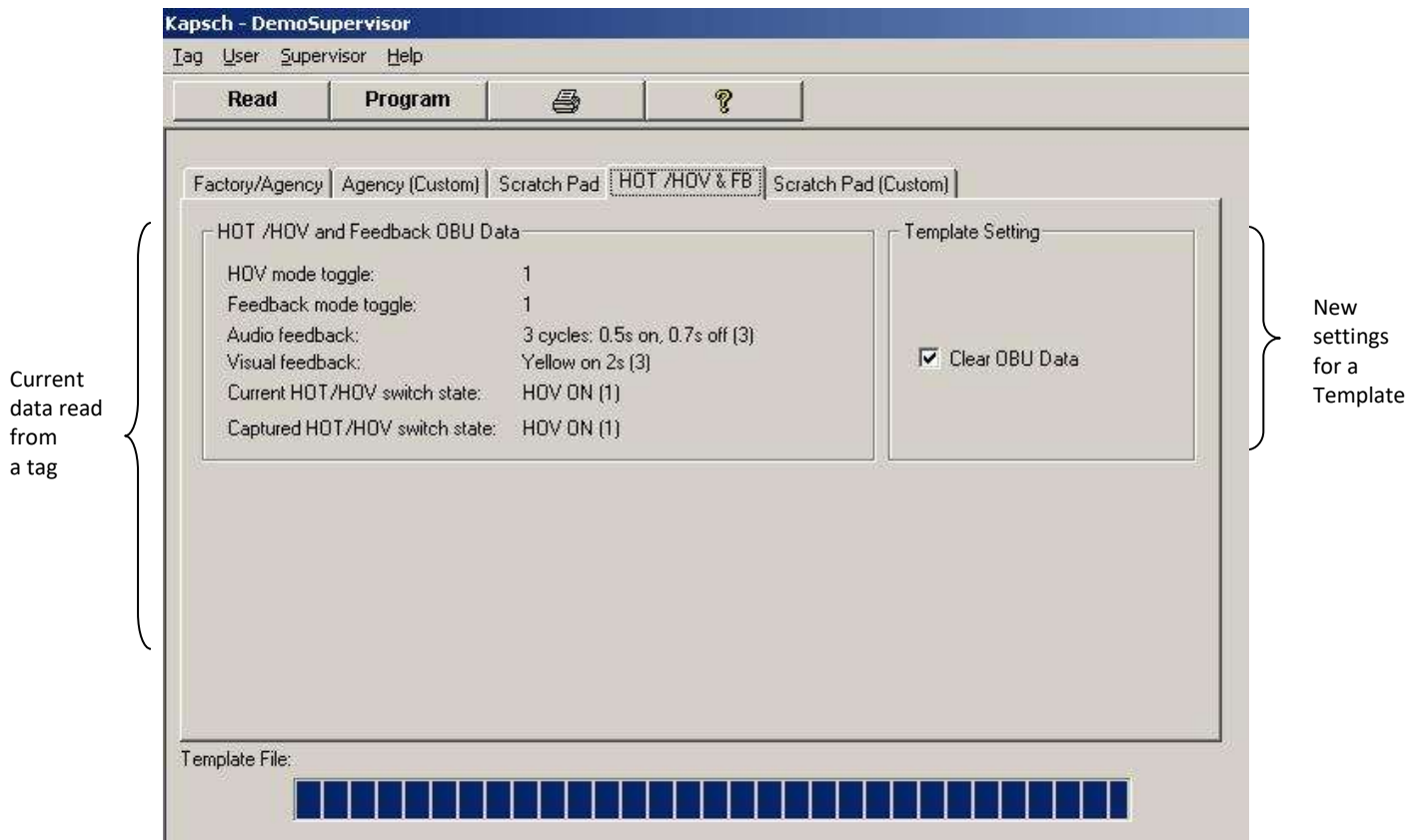

Saving a Template

Save a template to retain any changes made to a template or to save read tag data as a template.

Prerequisites: You must be logged on as a Supervisor.

1. Select menu **Supervisor** → **Save Template**. Select a location for the template.
The chosen location is displayed on screen.
2. To modify a template, save the template using the file name of the template you would like to modify.
3. To create a new template, save the template using a new file name.

Viewing and/or Printing Log Files

The logs of each read and write are contained in text files stored in the same directory as the file **tps.exe**. The different log files are shown in Table 7-3.

Table 7-3: The Log Files

Log file name	Log data type
TPSRDyyyyymmdd.TXT	read data for standard tags
TPSWRyyyyymmdd.TXT	write data for standard tags
TPSRD_TollBal_yyyymmdd.TXT	read data for toll/balance tags
TPSWR_TollBal_yyyymmdd.TXT	write data for toll/balance tags
TPSRD_HotFb_yyyymmdd.txt	read data for HOV and Feedback tags
TPSWR_HotFb_yyyymmdd.txt	write data for HOV and Feedback tags

These logs are easily viewed and printed using Excel. Log files are only created once data is created to populate the log (i.e, there will not be a read data log for toll/balance tags if no toll/balance tags were read). There may be more than one set of log files if the program was exited and subsequently re-started.

Prerequisites: None.

Note: The Excel options selected when opening the log file is the same for all versions of Excel, although the exact procedure for setting these options may differ slightly.

1. From Excel, open the log file. Be sure to select **Text Files** or **All Files** from the **Files of type** drop-down box to view the text files. The Excel text import wizard launches.
2. Select **Delimited**. Select **Next** to proceed.
3. Select the **Comma** check box for the **Delimiters**. Clear the check boxes of all other Delimiter types.
4. Ensure the **Treat consecutive delimiters as one** check box is cleared. Select **Next** to proceed.
5. Keep the **Column data format** selected as **General**. Select **Finish**. The log file appears in Excel for viewing, with each data field assigned a unique column.
6. Use the Excel print features to print the log file.

APPENDIX

Placement of OBUs in the AU Drawer Cradle

The following illustrations indicate the correct placement of each tag type in the cradle to ensure successful programming.

Placement of the LCD in the AU drawer:

NOTE: Ensure the OBU is oriented in the AU Drawer Cradle as in the diagram

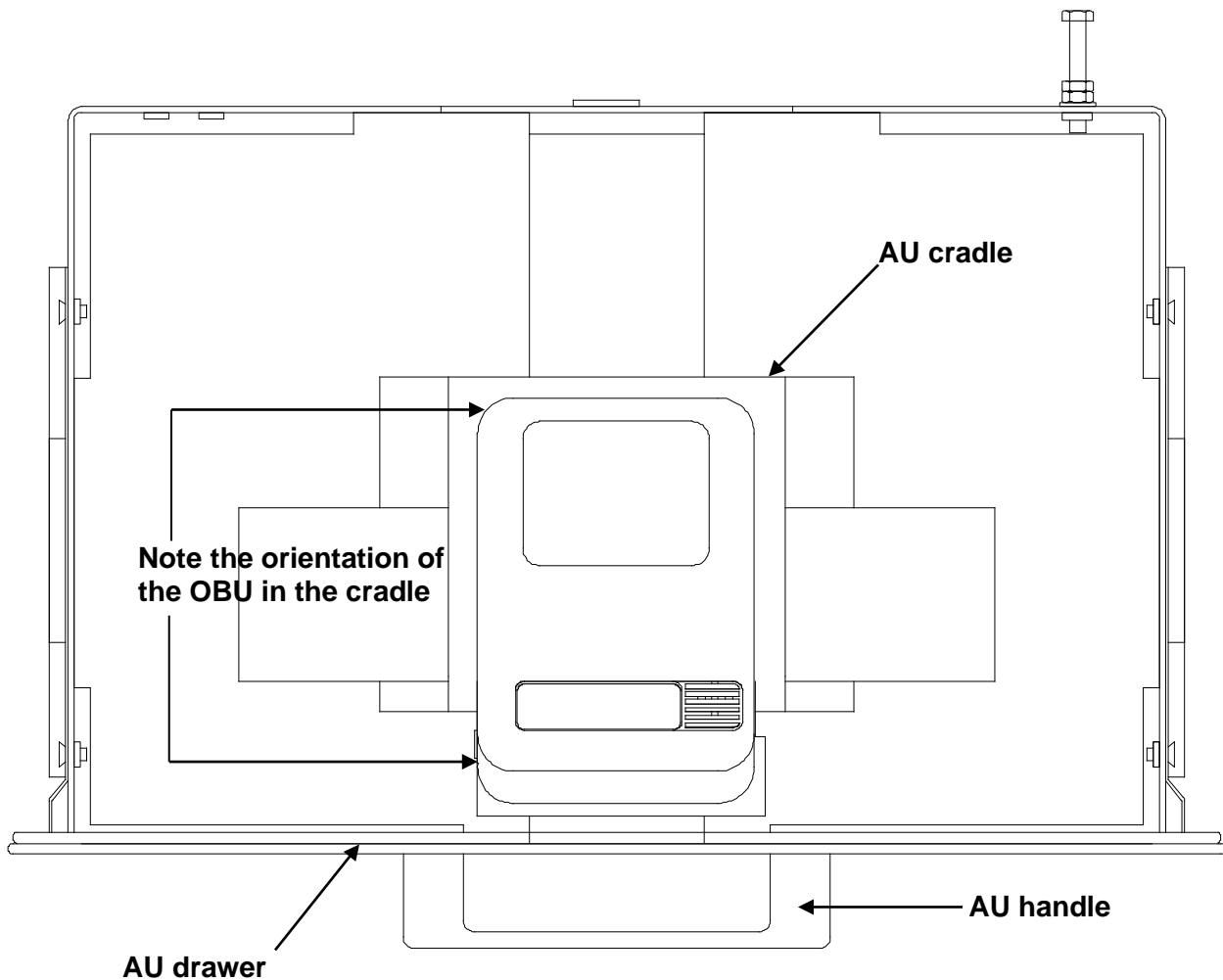

Placement of the LPT in the AU drawer:

NOTE: Ensure the OBU is oriented in the AU Drawer Cradle as in the diagram.

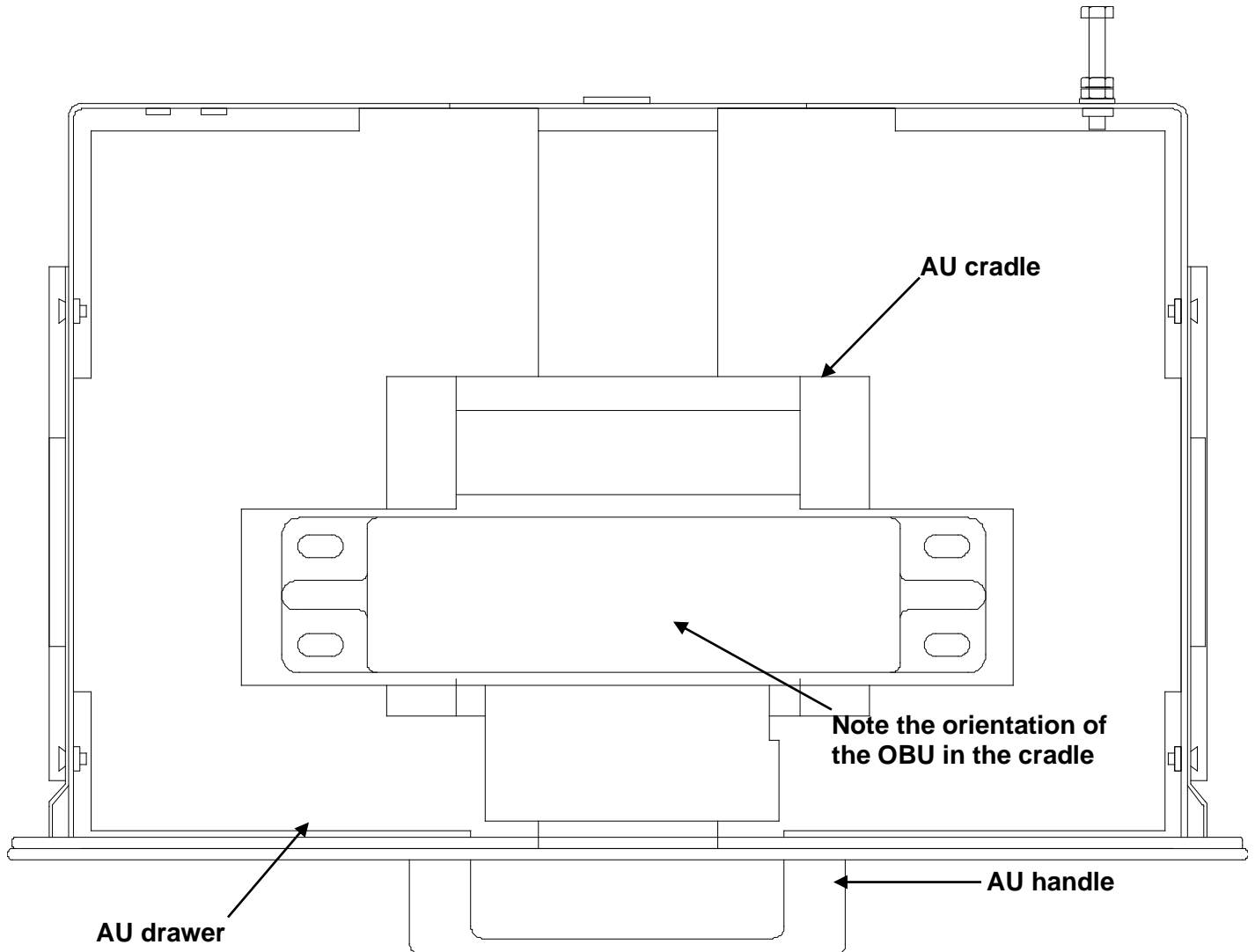

Placement of the CVO in the AU drawer:

NOTE: Ensure the OBU is oriented in the AU Drawer Cradle as in the diagram.

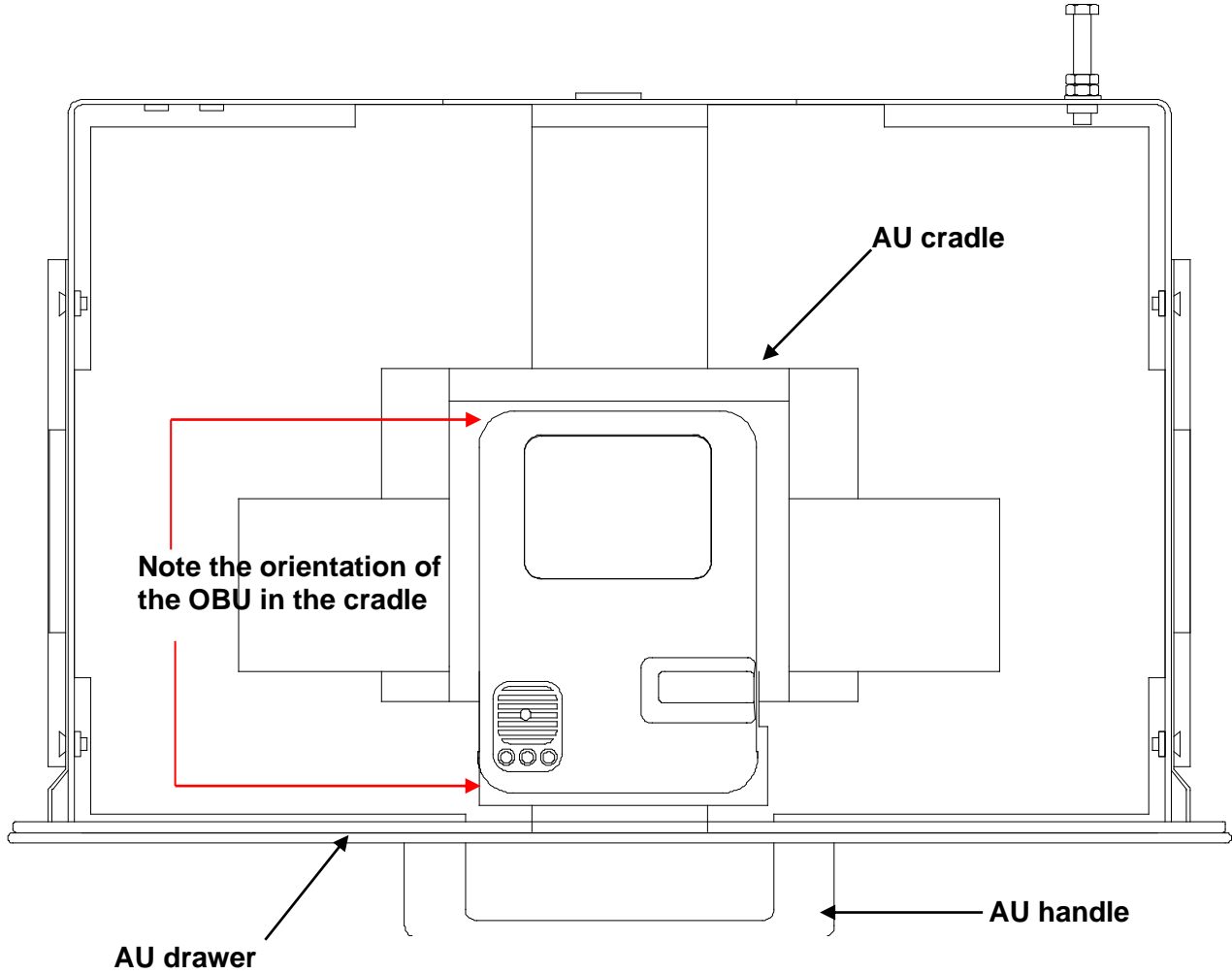

Placement of the G4 OBU in the AU drawer:

NOTE: Ensure the OBU is oriented in the AU Drawer Cradle as in the diagram.

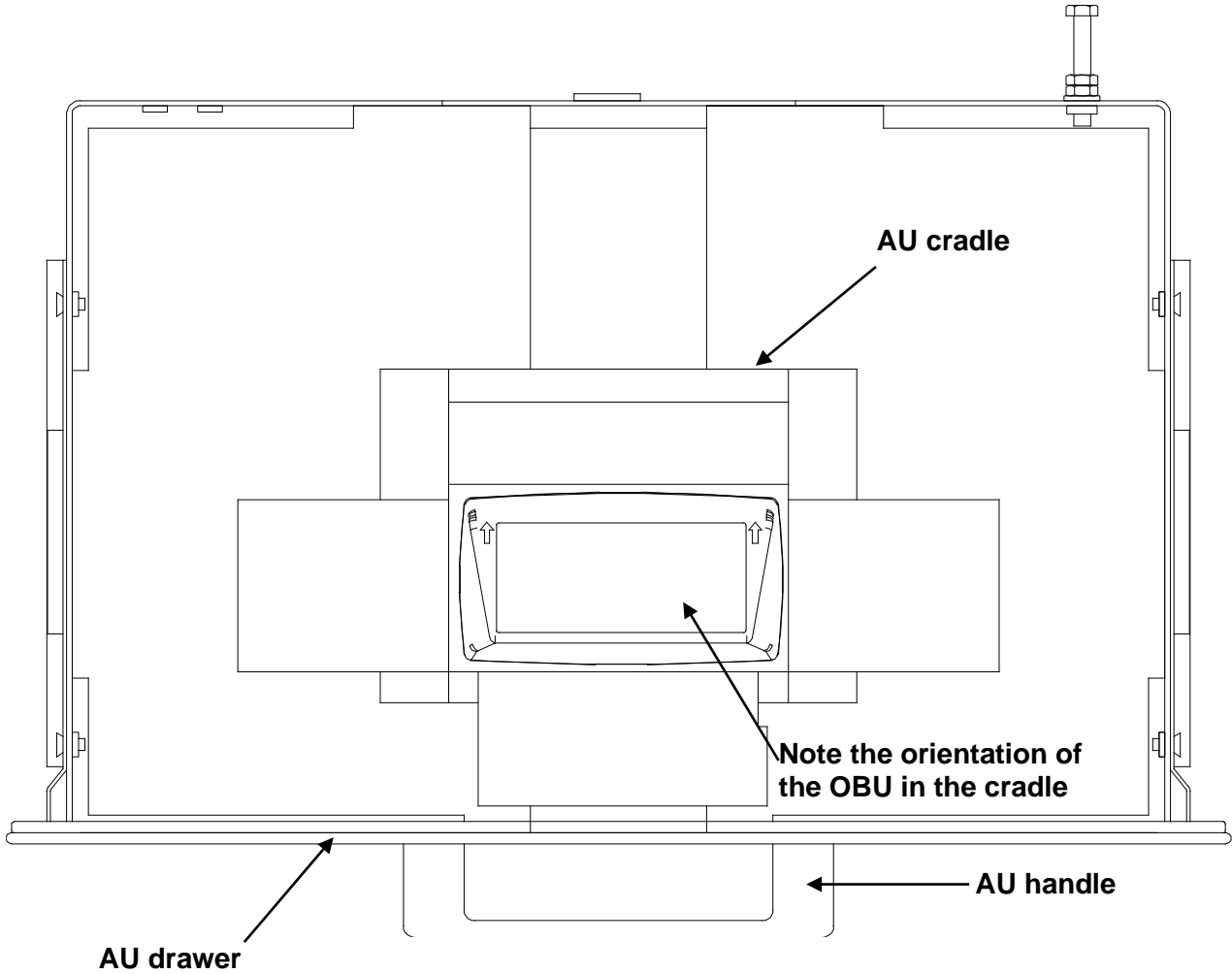

Placement of the G3B OBU in the AU drawer:

NOTE: Ensure the OBU is oriented in the AU Drawer Cradle as in the diagram.

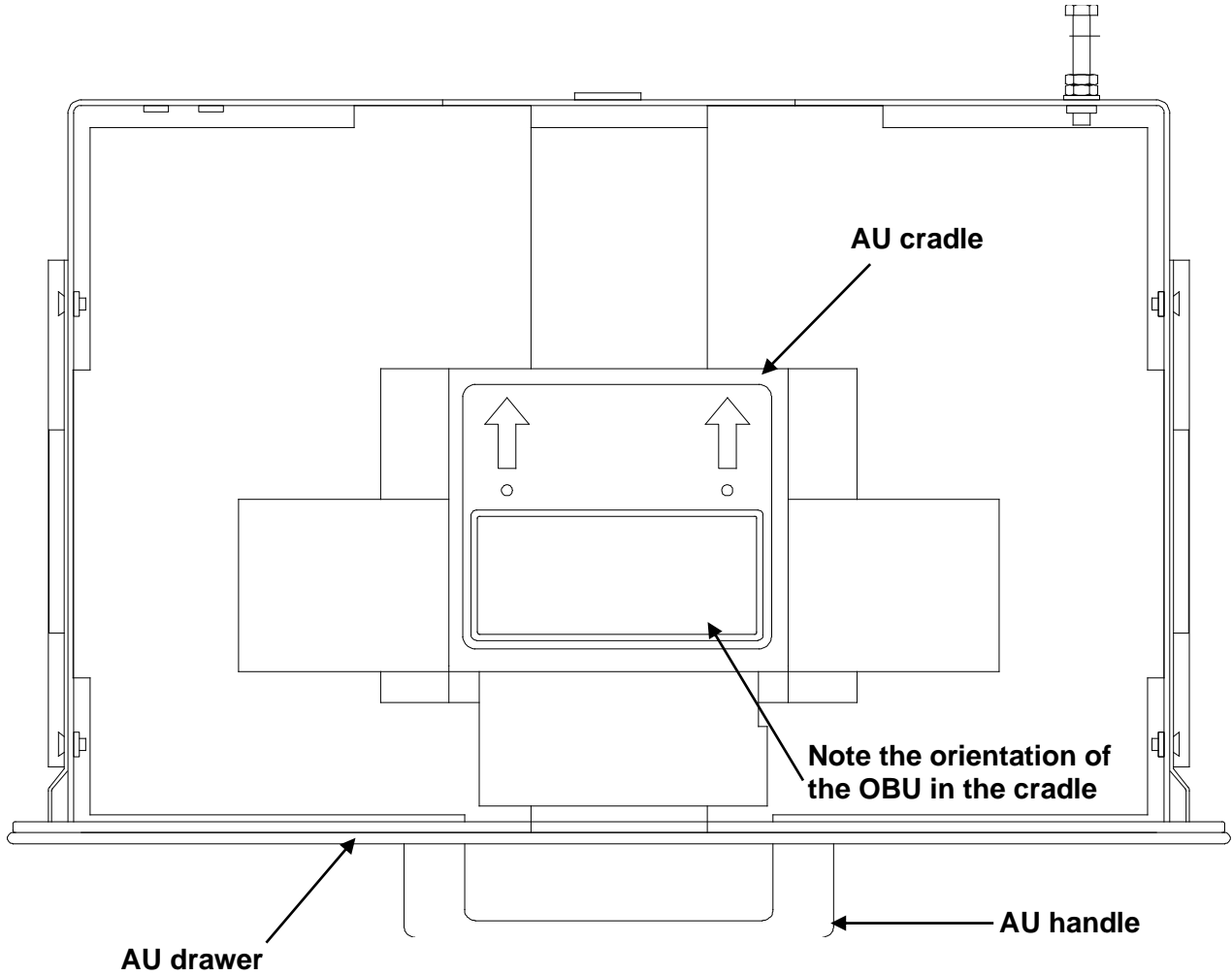

Placement of the FME OBU in the AU drawer:

NOTE: Ensure the OBU is oriented in the AU Drawer Cradle as in the diagram.

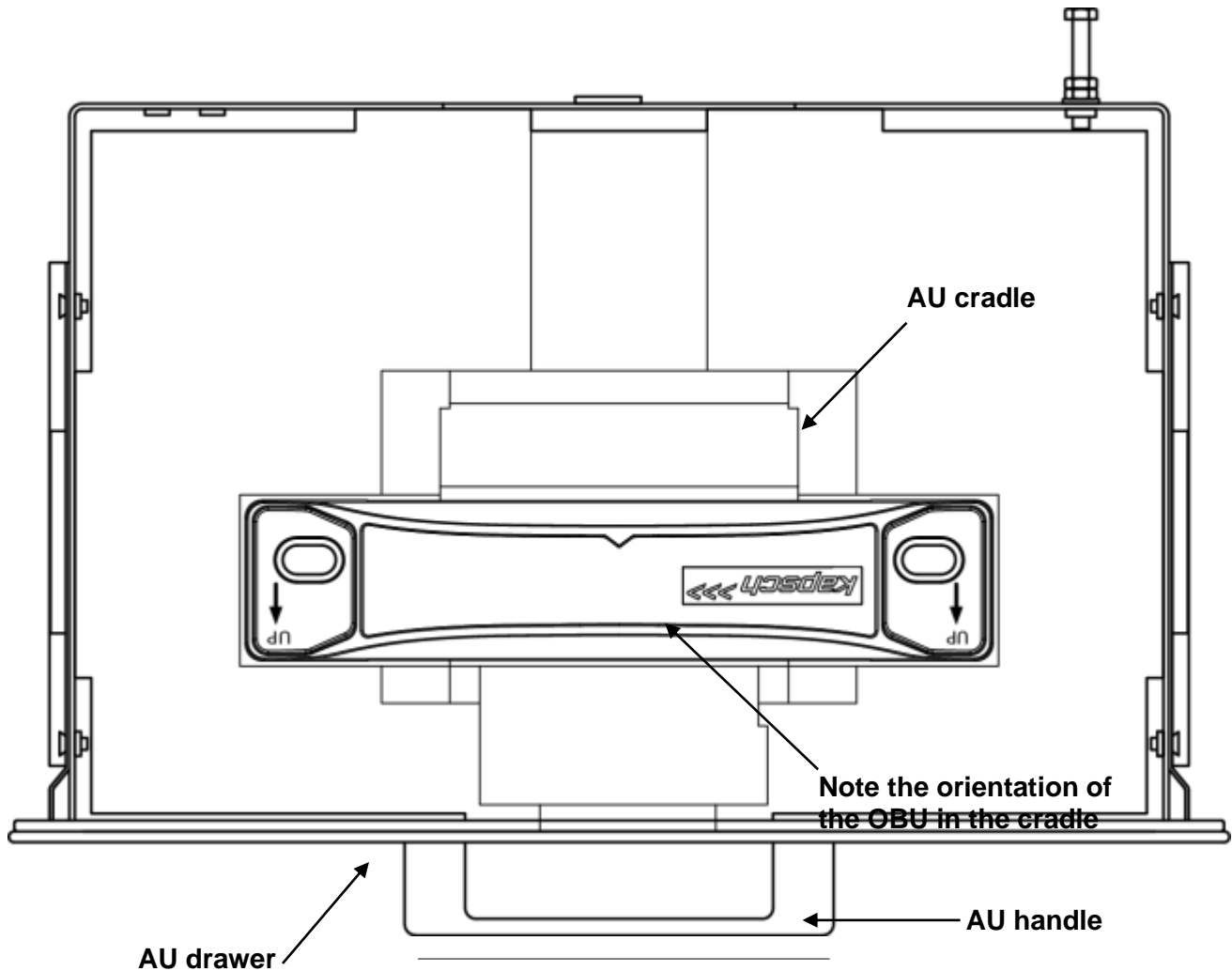

T500 Tag Programming Station

Placement of the HOT OBU in the AU drawer:

NOTE: Ensure the OBU is oriented in the AU Drawer Cradle as in the diagram.

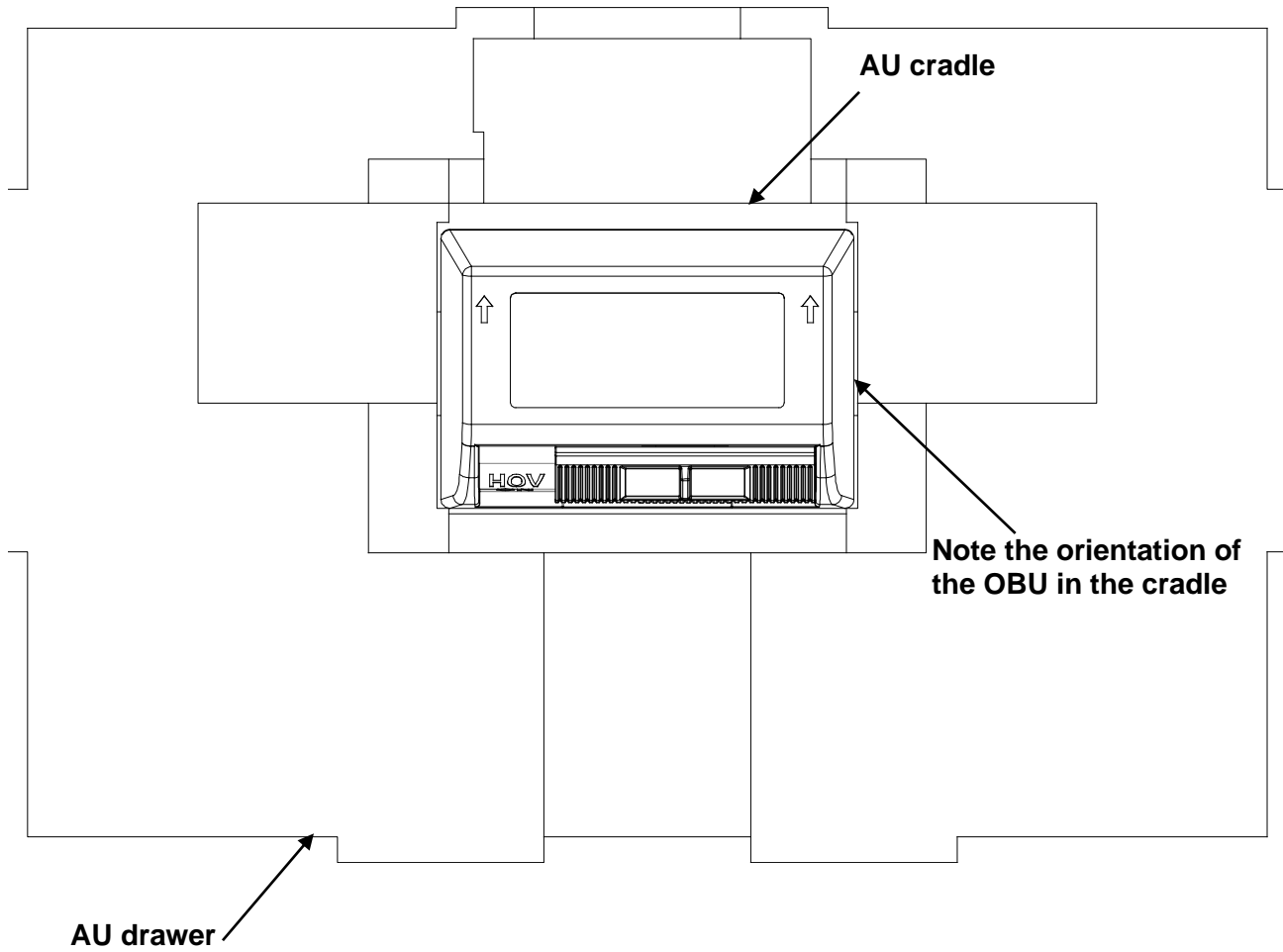

Accessing Documentation

You can access the documentation package for the T500 Tag Programming Station online at <http://dds.kapsch.ca>. A Username and Password can be obtained from Kapsch TrafficCom .

The documentation package includes:

- Bill of Materials
- Assembly Drawings
- Schematic Drawings
- Parts Specifications (for purchased items)
- Operator and Maintenance Manuals
- Installation Instructions
- Software Design Documents (Context Diagrams, Data Flows, etc.)
- As-built installation drawings (services)

Acronyms

Term	Meaning	Reference or example
AC	Alternating Current	
agency	customer	
AU	Antenna Unit	The portion of the TPS that houses both the RF antenna and the drawer to hold the tag.
CD	Compact Disc	Device used to store electronic data
CD-ROM	Compact Disc - Read Only Memory	
factory	Kapsch TrafficCom	
F	Feedback	G4F transponder
FME	Front Mount Exterior	A tag mounted on the exterior of the vehicle
FPT	Flat Pack Transponder	A tag mounted on the interior of the windshield
HOV	High Occupancy Vehicle	
ID	identification	
Kapsch	Kapsch TrafficCom	
LCD	Liquid Crystal Display	LCD transponder
LED	Light Emitting Diode	TPU front panel indicators
LPT	License Plate Transponder	A tag mounted on the front license plate
OBU	On Board Unit	Also referred to as a transponder or tag
operators	includes users and supervisors	
RF	Radio Frequency	Broadcast band transmission frequencies
tag	transponder	
template	tag configuration data file	
TPS	Tag Programming Station	The piece of equipment, including software, necessary to allow users to configure data stored in tags
TPU	Tag Programming Unit	The portion of the TPS that houses the electronics to support RF communications with the tags
QMS	Quality Management System	
UI	User Interface	
UPS	Uninterruptible Power Supply	
VAC	Volts Alternating Current	

T500 Tag Programming Station

Term	Meaning	Reference or example
write	program	