

JANUS® MULTI-PROTOCOL READER 2.4

OPERATIONS AND MAINTENANCE MANUAL

QMS EDITION – ISO 9001:2015

DOCUMENT: UM 360467-110

REVISION:D

DATE: March 6, 2023

Kapsch TrafficCom:

6020 AMBLER DRIVE
MISSISSAUGA, ON L4W 2P1
TEL: (905) 624-3025
FAX: (905) 624-4572

2855 PREMIERE PARKWAY, SUITE F
DULUTH, GA 30097
TEL: (678) 473-6400
FAX: (678) 473-9003

This Page Intentionally Left Blank

FCC License Notice:

This equipment emits RF signals. In order to operate this equipment the customer must obtain a separate FCC Part 90 Site license for each location. In addition, the FCC ID component identification **JQU802295A, or JQU802295A-A, or JQU802870** must appear on a label on the front of the RF Modules installed in these Readers.

The power output of a module at ambient ($P_{\text{out(amb)}}$) shall be constrained using internal or external Tx attenuation so that the following is satisfied:

$$P_{\text{out(amb)}} \leq 43.77 \text{ dBd} - G_{\text{fund}};$$

Where G_{fund} is the net gain from antenna connector on the RF module to the antenna radiated signal. The antenna gain is expressed in **dBd**. $P_{\text{out(amb)}}$ is expressed in **dBm**.

The Power output from the amplifier assembly of a module plus external amplifier at ambient (AmpOut(amb)) shall be constrained using module internal TX attenuation so that the following are both satisfied:

$$\text{AmpOut(amb)}: \leq 39 \text{ dBm}; \text{ and}$$

$$\text{AmpOut(amb)}: \leq 43.77 \text{ dBmd} - G_{\text{fund}};$$

where G_{fund} is the net gain at fundamental frequency from the antenna connection on the amplifier assembly to the antenna radiated signal where the antenna gain is expressed in dBd.

The net gain at the second harmonic from the antenna connection on the amplifier assembly to the antenna radiated signal shall be:

$$G_{2\text{nd}} \leq G_{\text{fund}} - 14\text{dB}.$$

Note: This device complies with Part 15 of the FCC Rules. Operation is subject to the following two conditions: (1) this device may not cause harmful interference and (2) this device must accept any interference received, including interference that may cause undesired operation.

Note: This equipment has been tested and found to comply with the limits for a Class A digital device, pursuant to Part 15 of the FCC Rules. These limits are designed to provide reasonable protection against harmful interference when the equipment is operated in a commercial environment. This equipment generates, uses, and can radiate radio frequency energy and, if not installed and used in accordance with the instruction manual, may cause harmful interference to radio communications. Operation of this equipment in a residential area is likely to cause harmful interference in which case the user will be required to correct the interference at their expense.

Changes or modifications not expressly approved by Kapsch TrafficCom could void FCC compliance and the authority to operate the equipment.

Note: IEC 60950-1 and/or EN60950-1, First Edition, Information Technology Equipment – Safety – Part 1: General Requirements require that this equipment must be located in a RESTRICTED ACCESS LOCATION (RAL). Only authorized personnel can have access to the equipment.

MODEL 802295A-A PART 2 of 2 RF AMPLIFIER ASSEMBLY

The amplifier is only approved for use with the corresponding module (part 1 of this model)

115VAC – 230VAC, 2A, 60Hz

SOFTWARE/FIRMWARE Note

The current software set is identified in the Software Release document.

The active Reader software and firmware version is displayed in the Reader web interface.

FACTORY SUPPORT SERVICE

For Return Material Authorization (RMA) numbers please telephone: 905 624-3020.

For Kapsch Service information and other requests please FAX: 905 624-4572.

NOTICE

The information presented in this document is current although it is subject to change. As such, **Kapsch TrafficCom** assumes no liability on behalf of the USER with respect to interpretation based on the use of this information

Kapsch TrafficCom ©2021

COPYRIGHT STATEMENT

All information contained herein is proprietary to, and may only be used with express, written permission from, Kapsch TrafficCom Canada Inc. Copyright © 2021 Kapsch TrafficCom Canada Inc.

IMPORTANT!

NOTICE OF PATENTS:

Kapsch TrafficCom

has patented or has patents pending on critical design features of the item or items described herein. Contact Kapsch TrafficCom for all queries regarding patents.

Document Revision Control

Version Date	Revision	Editor	Changes
2023/03/6	D	E. Rolo	ECN 23005 Change the RF exposure statement from a caution to a warning.
28 Mar 2022	C	B. Mac	ECN 22021 revised address for US office
2021/04/13	B	E. Rolo	Initial Release

This Page Intentionally Left Blank

Table of Contents

1. ABOUT THIS MANUAL..... 17

Technical Background..... 17

Assumptions..... 17

Warnings and Cautions..... 17

New Feature Symbol 20

Conventions used in this manual..... 20

2. OVERVIEW 23

Introduction 23

Overview of the MPR 2.4 Electronic Toll Collection (ETC) Subsystem 23

JANUS MPR 2.4 system components..... 23

Antenna 27

Module Descriptions..... 28

Smart Multi-protocol RF Module (MRFM-S)..... 28

Distributions Module (DSM) and Rack..... 30

Configuration Module (CFM) 31

Control Module (CTM) 32

Synchronization Port Module (SPM)..... 34

Lane Port Module (LPM) 35

Power Supply Module (PSM) 36

Ethernet Switch Module (ESM) (Optional) 38

Reader web interface 39

3. OPERATING PROCEDURES..... 42

Starting up the Reader 42

Connecting a service laptop to the Reader 43

Accessing the Reader web interface 43

Shutting down the Reader45

Manually switching a Reader to the redundant side45

Logging out of the web interface46

Changing your password46

Resetting a forgotten password46

Checking Reader Status.....47

Configuring the Reader52

 Using the Reader Setup Wizard 57

 Channel configuration..... 59

 Frequency and Time Multiplexing 61

 RF Attenuation..... 62

 Programming tags..... 62

 Configuring Reader switch-over events..... 64

 Multi-protocol tag acquisition sequence building 65

 Reader supported protocols 66

 Reader synchronization 69

 Example building a Frame Sequence 69

 Configuration Alignment..... 71

Commands and controls75

4. THEORY OF OPERATIONS 142

Multi-protocol RF Module Smart143

Power Supply Module (PSM)143

Lane Controller Port Module (LPM)145

Sync Port Module (SPM)145

Controller Module (CTM)145

Configuration Module (CFM)146

Distribution Module (DSM).....146

Multiple reader synchronization.....146

Transaction Buffering 149
 Buffering and Dual Ethernet LC Destination 149

Log files 150

5. INSTALLATION 154

Introduction 154

The earth ground system..... 155

Lightning protectors 156

Installing the Reader hardware 157

Installing a Lane Kit 159

Use of the RF amplifier 165

Performing Lane Tuning 167

The Synchronization circuit 167

The Ethernet Network 170

Reader connections to the LC via the LPM serial ports 171

Reader connections to the LC and Inter-Reader via Ethernet 173
 Configuring an LC Ethernet network..... 173

Lane Assignment 174
 Multiple Reader Lane Assignment 175
 Configuring Voting Time 179
 Configuring Channel Weight for straddle antennas 181

6. TROUBLESHOOTING AND TESTING 183

Troubleshooting Methodology 183

LED Statuses 185

Troubleshooting tree: LC Ethernet 1 Port communications not working 187

Troubleshooting tree: Ethernet 2 Port communications not working 188

Troubleshooting tree: LPM Serial Port communications not working 189

Troubleshooting tree: MRFM-S (Plus) not working 190

Troubleshooting tree: Synchronization not working 191

Troubleshooting tree: Reader does not automatically switch back to Primary side after fault recovery 195

Troubleshooting tree: Simultaneous faults on Primary and Secondary CTMs 196

Identifying failures on the primary and/or secondary side..... 197

Events that cause an automatic switchover 197

Reader recovery actions..... 198

Testing the CTM Ethernet 1 port 199

Testing the Synchronization Circuit..... 199

Testing the MRFM-S slots 199

Lane Check Diagnostic..... 200

7. MAINTENANCE PROCEDURES 202

Corrective maintenance procedures 202

Preventive maintenance procedures and scheduling 203

MRFM-S (Plus) replacement..... 204

Antenna replacement 205

RF cable or connector replacement..... 206

CTM replacement 206

SPM replacement..... 208

LPM replacement..... 208

PSM replacement..... 209

CFM replacement..... 210

Replacing a PSM fuse 211

Rebooting the CTM 212

Updating Reader Software 213

Configuration management..... 215

 Saving the Reader configuration..... 215

 Loading a reader configuration file..... 215

 Resetting the Reader configuration to the factory default 216

User Administration 216

Network Time Protocol 218

Saving Reader Log files 220

APPENDIX A MISCELLANEOUS..... 223

Using PuTTY to connect to the DIAGNOSTIC PORT 223

Using HyperTerminal to connect to the DIAGNOSTIC PORT 223

Accessing Documentation 224

Technical Specifications and Pin outs 225

Antenna Specifications 230

RF Cable Specifications 231

Synchronization Cable and Terminal Block specifications 232

Spares and Tools 232

Reference Documents 234

Acronyms and Synonyms 235

Glossary 241

Differences between MPR2.4 and MPR 2.3 242

Differences between MPR2.4 and the Badger and JANUS Readers..... 243

APPENDIX B FCC APPROVED CHANNEL FREQUENCIES AND SELECTION247

APPENDIX C UI READER STATUS INDICATORS249

APPENDIX D NON-REDUNDANT READER250

List of Figures

FIGURE 2-1: A MPR 2.4 REDUNDANT READER 25

FIGURE 2-2 MPR 2.3 REDUNDANT READER (SHOWN WITH MRFM-S MODULES)..... 26

FIGURE 2-3: IAG 3 ANTENNA 27

FIGURE 3-1: EXAMPLE FRAME SEQUENCE (BALANCED PROTOCOL WEIGHTING)..... 68

FIGURE 3-2: EXAMPLE FRAME SEQUENCE (6B WEIGHTED) 68

FIGURE 3-3: EXAMPLE FRAME SEQUENCE WITH DUMMY FRAME..... 68

FIGURE 4-1: READER POWER DISTRIBUTION..... 144

FIGURE 5-1: EARTH GROUND SYSTEM (WITH RECOMMENDED LIGHTNING PROTECTORS SHOWN) 156

FIGURE 5-2: AC MAINS 157

FIGURE 5-3: LC DATA CABLE INSTALLATION..... 158

FIGURE 5-4: GENERIC IAG3 MOUNTING DIMENSION INFORMATION..... 161

FIGURE 5-5: INLINE ORT ANTENNA INSTALLATION 161

FIGURE 5-6: STAGGERED ORT ANTENNA INSTALLATION 162

FIGURE 5-7: RF CABLE INSTALLATION SCHEMATIC BI-STATIC OPERATION 165

FIGURE 5-8: RF CABLE INSTALLATION SCHEMATIC BI-STATIC TDM ONLY OPERATION..... 165

FIGURE 5-9: RF CABLE INSTALLATION SCHEMATIC BI-STATIC OPERATION WITH RF AMPLIFIER 166

FIGURE 5-10: RF CABLE INSTALLATION SCHEMATIC MONO-STATIC OPERATION (MRFM-S PLUS ONLY) 166

FIGURE 5-11: SYNCHRONIZATION CIRCUIT SCHEMATIC FOR THREE READERS 169

FIGURE 5-12: SCHEMATIC OF A THREE-READER IR NETWORK..... 170

FIGURE 5-13 SCHEMATIC OF A THREE-READER LC NETWORK 171

FIGURE 5-14: TWO READERS COMMUNICATING WITH ONE OBU 175

FIGURE 5-15: THREE READERS COVERING ONE DIRECTION OF WIDE LANE ORT TRAFFIC..... 177

FIGURE 5-16: THREE WIDE ORT LANES WITH TWO STRADDLE ANTENNAS	182
FIGURE 6-1: SIGNAL FLOW DIAGRAMS	184
FIGURE 7-1: PSM FUSE AND FUSE HOLDER	211

List of Tables

TABLE 2-1: READER MENU SUMMARY 40

TABLE 3-1: COMMUNICATIONS FIELDS 47

TABLE 3-2: POWER SUPPLY STATUS FIELDS..... 49

TABLE 3-3: RF MODULES FIELDS 49

TABLE 3-4: READER STATUS FIELDS 51

TABLE 3-5: READER CONFIGURATION PAGES..... 53

TABLE 3-6 CONFIGURATION ALIGNMENT OPERATION 71

TABLE 3-7: COMMANDS AND CONTROLS 75

TABLE 4-1: BOOLEAN LOGIC TRUTH TABLE FOR SYNCHRONIZATION OF TWO READERS 149

TABLE 4-2: LIST OF LOG FILES TYPES..... 150

TABLE 4-3: LIST OF FIELDS IN A TRANSACTION LOG REPORT 151

TABLE 5-1: LOCATIONS FOR THE INSTALLATION OF LIGHTNING PROTECTORS 156

TABLE 5-2: ANTENNA MOUNTING AND LANE CONFIGURATION 159

TABLE 6-1: CTM LED STATES EXPLAINED 185

TABLE 6-2: PSM LED STATES EXPLAINED 186

TABLE 6-3: MRFM-S (PLUS) LED STATES EXPLAINED 186

TABLE 6-4: SWITCHOVER TRIGGERS..... 197

TABLE 6-5: FAILURES AND THE READER RECOVERY ACTIONS THEY TRIGGER..... 198

TABLE 7-1: IMPORTANT DIFFERENCES BETWEEN THE BADGER READER AND THE JANUS READER 243

This Page Intentionally Left Blank

1. ABOUT THIS MANUAL

The JANUS® Multi-Protocol Reader 2.4 Operations and Maintenance Manual consists of two main parts :

- Operations
- Maintenance

Sections and subsections within these main parts are used to present theoretical as well as practical and procedural information. See the table of contents for more details on each section.

This manual is the main reference document used during training. Training is provided by Kapsch TrafficCom for the following personnel.

- Operations
- Installations
- Maintenance
- Service

This manual is also used as a reference by Kapsch TrafficCom for its service-certified technical service personnel in the field once training has been completed.

This version of the manual is current to and uses screens and information pertaining to software version 2020oct22a-MPR24. Earlier versions may not support all configuration parameters and features shown or described, while later versions may have additional features and configuration parameters.

Technical Background

Personnel must have an electrical/electronic technical background, understanding of toll and RF, and some prior experience using web browsers.

Assumptions

A redundant JANUS® Multi-Protocol Reader 2.4 used for Electronic Toll Collection (ETC) is assumed throughout the manual.

Warnings and Cautions

Warnings

Warnings indicate a risk of bodily harm and include a symbol indicating the type of injury risked.

**WARNING:**

WARNING DESCRIPTION HERE.

The following warnings appear in the manual:



AN IMPROPERLY GROUNDED READER COULD RESULT IN ELECTRIC SHOCK. ENSURE A HIGH CURRENT EARTH GROUND CONNECTION IS ESTABLISHED BEFORE CONNECTING SUPPLY POWER TO THE READER.



THE MODULES MAY HAVE SHARP EDGES. HANDLE THE MODULES CAREFULLY. WHENEVER POSSIBLE, USE A MODULE EXTRACTION TOOL TO REMOVE A MODULE.



THE MRFM-S or MRFM-S Plus MAY BECOME HOT UNDER NORMAL OPERATING CONDITIONS. ENSURE THE MRFM-S (PLUS) HAS COOLED DOWN OR WEAR GLOVES WHEN HANDLING THE MRFM-S (PLUS).



THE PSM MAY BECOME HOT UNDER NORMAL OPERATING CONDITIONS. ENSURE THE PSM HAS COOLED DOWN OR WEAR GLOVES WHEN HANDLING THE PSM.



EXPOSED HIGH VOLTAGE IS PRESENT IN THE PSM. ENSURE THAT THE POWER SWITCH IS SET TO THE OFF POSITION AND THAT THE AC INPUT POWER CORD IS DISCONNECTED BEFORE REMOVING THE PSM.



INSTALLING A FUSE OF THE WRONG TYPE OR RATING MAY CAUSE A FIRE. ENSURE A TIME-LAG FUSE RATED FOR 10A, 250VAC IS INSTALLED.



KEEP AT LEAST 100 CM AWAY FROM THE RADIATING FACE OF THE ANTENNA WHEN THE RF MODULE IS CONNECTED AND OPERATING.

Cautions

Cautions indicate a risk of damage to equipment or loss of data.



The following cautions appear in the manual:

Improper modification of configuration parameters may adversely affect system operation. The default values may not be appropriate for the specific application. It is the system integrator's responsibility to tailor the configuration parameters to the specific operating environment.

Both CTMs in a redundant Reader must be properly configured. Each CTM has its own browser interface and is configured independently, unless Configuration Alignment is enabled. If Configuration Alignment is not enabled, ensure any configuration changes made to one CTM are applied to the other CTM, as required.

Log file formats are not under ICD control and the format may change without prior notification. Log files are for diagnostic purposes only and are not guaranteed to be maintained in non-volatile storage.

Excessive bending or kinking can damage the RF feedline cables. Do not excessively bend or kink the RF feedline cables when installing them between the antennas to the Reader enclosure.

Removing a powered CTM from the Reader rack can damage the CTM. Before removing a CTM from the Reader, ensure that power on the affected side of the Reader is turned off, i.e. the power switch on the PSM is in the off position, or the PSM AC input power cord is disconnected.

To avoid damaging the modules, ensure that the connector on the module is properly aligned with the connector on the DSM back plane before the module is securely plugged into the DSM.

During software/firmware activation (typically less than 60 seconds), the Reader will switch over to the other side to process and report transactions, regardless of the position of the mode switch on the SPM module. Ensure that the other side is running normally and all lane

controller links are functioning. The Reader will be unable to process or report transactions if it is unable to switch over to the other side.

During software/firmware activation (typically less than 60 seconds), a non-redundant Reader is unable to process or report transactions.

The factory default configuration should not be restored on a running Reader. Save the current Reader configuration before resetting the Reader configuration to the factory default.

New Feature Symbol

The following symbol indicates a new feature for the MPR 2.4 reader.



New features include a Setup Wizard (see Using the Reader Setup Wizard, page 57); a mode to keep the Secondary side settings in sync with the Primary (see Configuration Alignment, page 71); a new Dual-Destination Buffering Mode option to allow independent tag buffering when using Dual Ethernet LC links; NTP status checking (see Network Time Protocol, page 218).

Conventions used in this manual

The following information is provided to the user to aid in understanding and readability.

Highlighting and callouts are used in the guide to indicate importance, or to indicate a change to the user.

Example:

Bolding of words is used in the following cases:

- To indicate that an action is required (example: Click the **Next** button.)
- To indicate a main menu item and/or a menu option (example: Select a feedback option from the **OBU Audible Feedback** drop-down box.

When required, tables listing screen fieldnames and/or column headings and their definitions or meanings are placed below selected screens to aid in understanding technical terms.

The terms **Tag**, **Transponder** and **On-board Unit** or **OBU** are interchangeable in this manual.

The terms **IAG** or **TDM** are interchangeable in this manual when referring to screens or the TDM protocol.

OPERATING INSTRUCTIONS

This Page Intentionally Left Blank

2. OVERVIEW

Introduction

The JANUS® Multi-Protocol Reader 2.4 (MPR 2.4) is part of the Electronic Toll Collection (ETC) Subsystem. Toll collection is the primary use of the Reader.

Overview of the MPR 2.4 Electronic Toll Collection (ETC) Subsystem

The MPR 2.4 Reader can interact with both active and passive OBUs. The MPR 2.4 is factory configured to enable all protocols. For an in-depth description of protocols and the MPR 2.4 ETC Subsystem, see Theory of Operations page 142.

Active OBU

For an active OBU, overhead antennas send out RF signals. As a vehicle equipped with an active OBU approaches a toll zone, the OBU receives an RF signal from the antenna. The OBU then starts transmitting data, which is received by the antenna and passed on to the Reader via an MRFM-S (Plus) module. The Reader processes and logs the OBU data, and then sends the information to the Lane Controllers (LCs). The Reader can also send data back to the OBU, such as an updated toll account balance.

Passive OBU

For a passive OBU, the antenna sends out a command or a continuous wave via an RF signal. As a vehicle equipped with a passive OBU approaches a toll zone, the OBU receives an RF signal from the antenna. **If commanded**, the OBU then starts transmitting data, which is received by the antenna and passed on to the Reader via an MRFM-S (Plus) module. The Reader processes and logs the OBU data, and then sends the information to the Lane Controllers (LCs). The Reader can also send data back to the OBU, such as an updated toll account balance.

JANUS MPR 2.4 system components

Figure 2-1: A MPR 2.4 Redundant Reader shows a rack equipped with eight Smart Multi-protocol Radio Frequency modules (MRFM-S).

A Lane Kit consists of:

- An antenna (see Figure 2-3)
- An MRFM-S(2) in Figure 2-1: A MPR 2.4 Redundant Reader) or an MRFM-S Plus
- NOTE: MRFM-S and MRFM-S Plus cannot be combined in one reader.
- Two feedline adapter cables (2 for MRFM-S and 1 for MRFM-S Plus)

- One Circulator (not required for MRFM-S Plus)
- One Circulator adapter cable LMR -400. (3'5" for 902-904MHz, 3'3" for all other frequencies) (not required for MRFM-S Plus)

The redundant Reader consists of:

Note: Numbers in the list below refer to those associated with Figure 2-1: A MPR 2.4 Redundant Reader. The DSM, and CFM are not shown in the figure.

- One rack and Distribution Module **1**
- Two Controller Modules (CTM) **3**, each equipped with an internal Main Controller (MC) and one Channel Group Controller (CGC)
- Two Configuration Modules (CFMs) attached directly to the DSM
- One Synchronization Port Module (SPM) **4**
- Two Lane Port Modules (LPM) **5** (Reader model dependent)
- One secondary Power Supply Module (PSM) **6**
- One primary Power Supply Module (PSM) **7**
- AC Power cords for the PSM's **8**

Note: Non-redundant Readers contain one CTM, one CFM, one LPM (Reader model dependent), and one PSM. For an illustration of a non-redundant reader, see Appendix C.

Additional installation components required are:

- Two RF cables from Reader to Circulator (type N male to type N female) (MRFM-S Only)
- Sealing tapes for RF connectors exposed to weather
- Lightning arrestors
- Optional Ethernet switch modules (ESMs)
- Sync and inter-reader Ethernet cabling (if required)
- Ethernet cables if ESMs used
- 300 CFM fan tray for operation above 131°F (55°C)

Additional Site requirements are:

- Cabinet with AC power, grounding, including reader ground bar,
- Mounting structure for antenna
- Ethernet or Serial cables to connect to the lane Controller(s)

Figure 2-1: A MPR 2.4 Redundant Reader

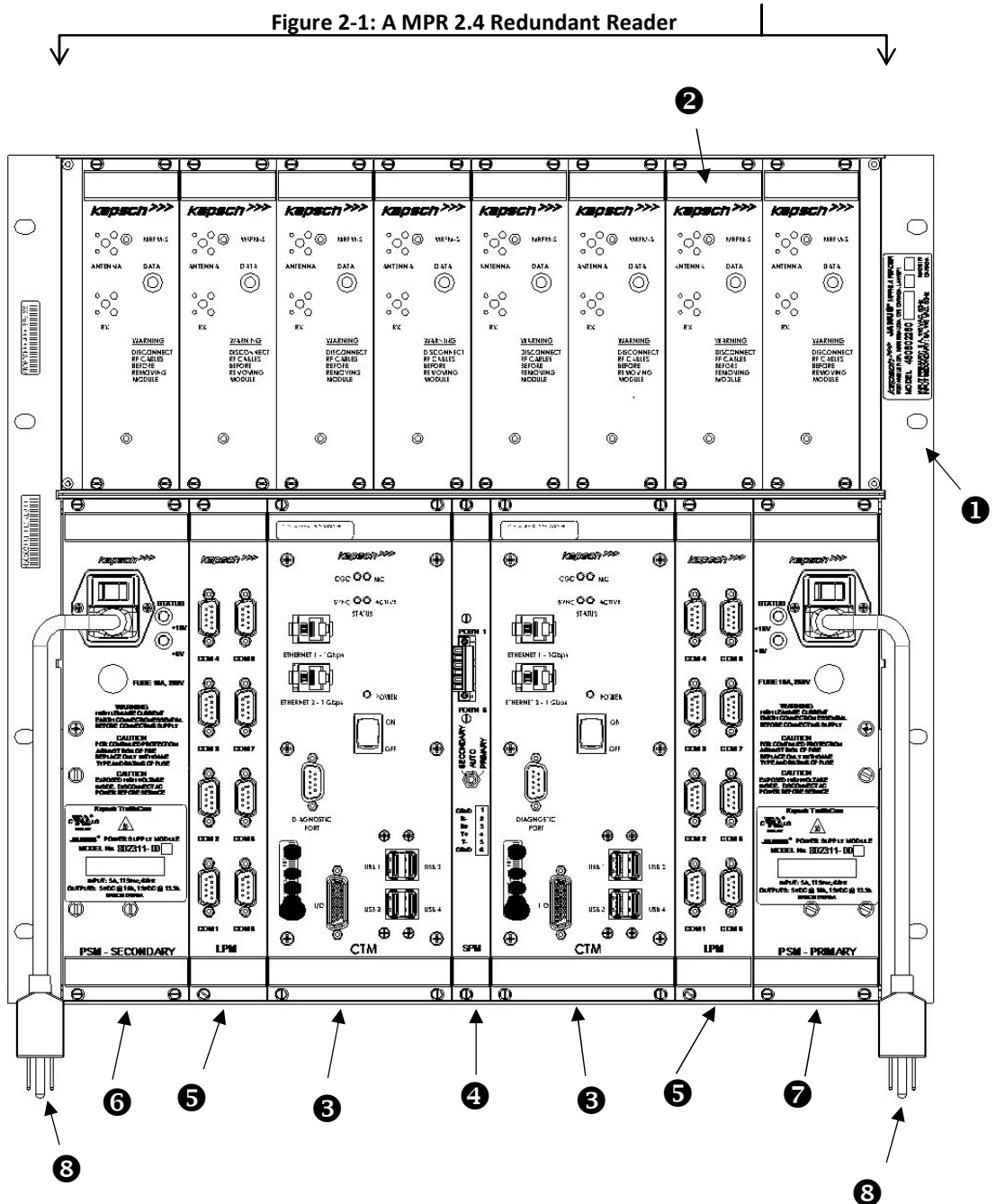
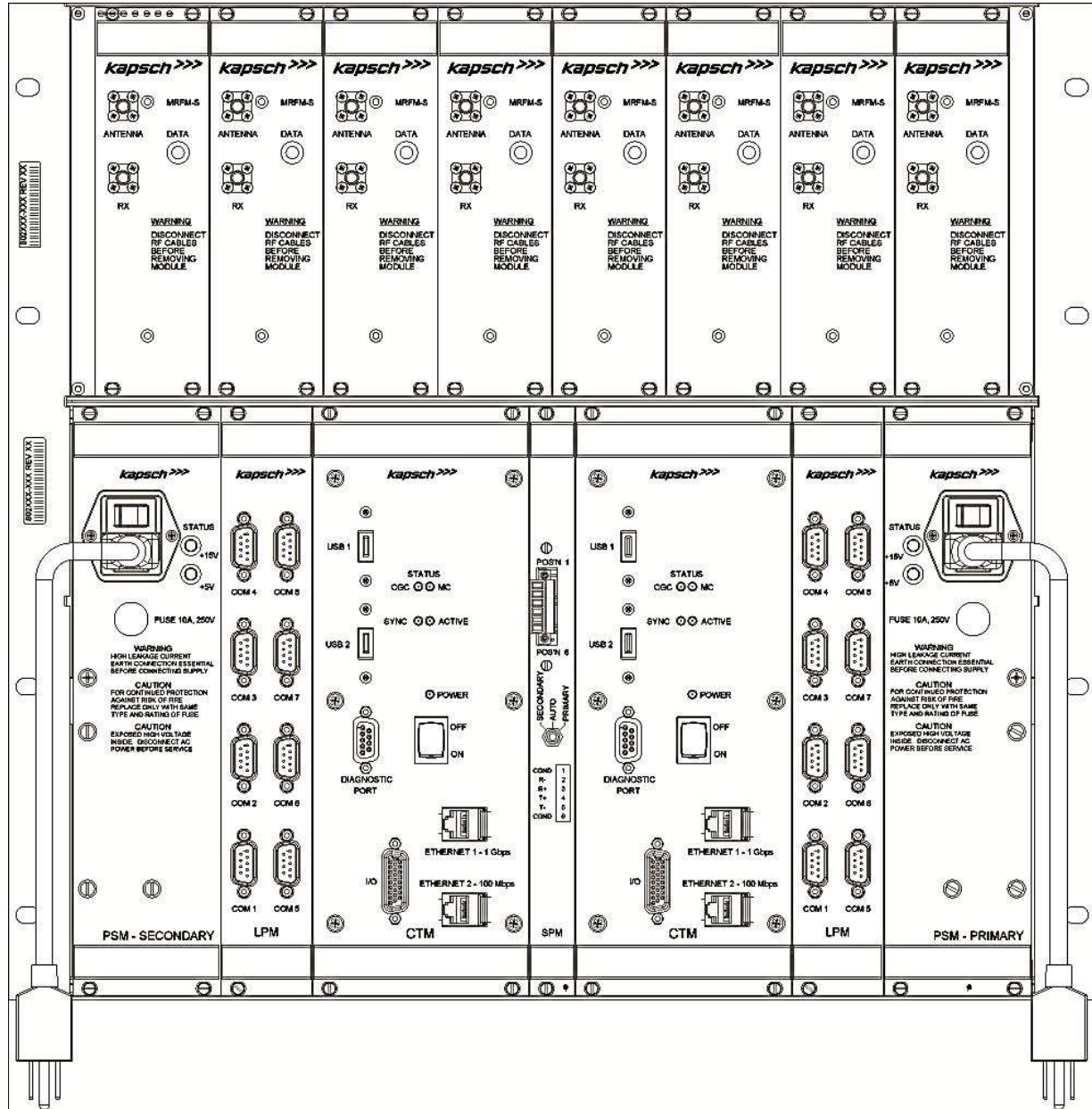
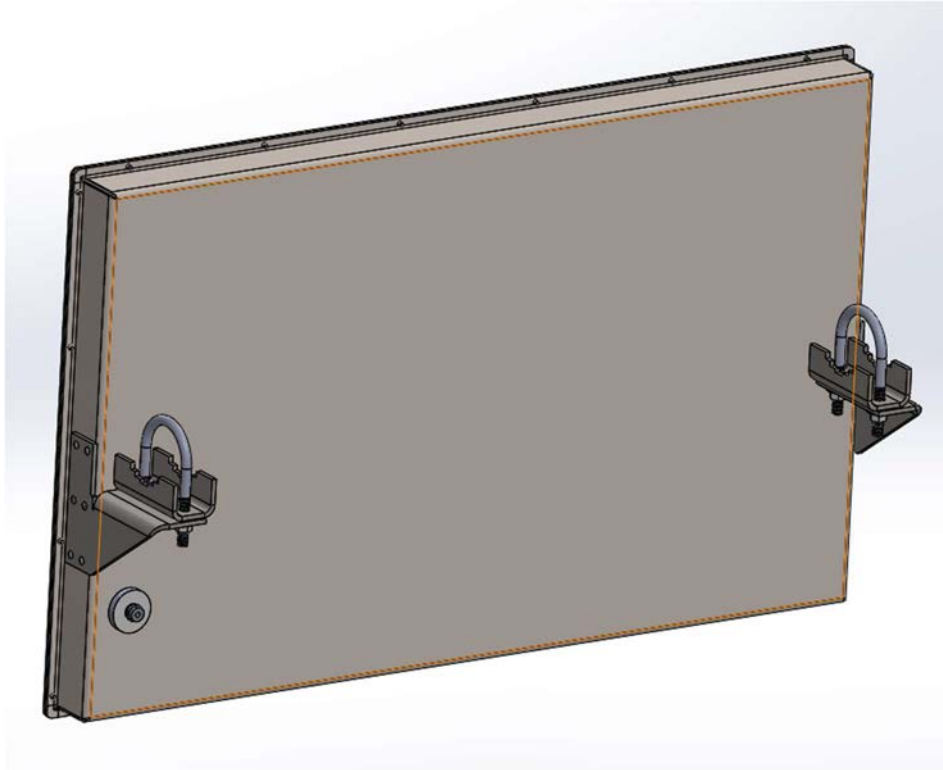

Figure 2-2 MPR 2.3 Redundant Reader (shown with MRFM-S modules)



Antenna

The antenna sends and receives RF signals to and from the vehicle On Board Units (OBUs). The IAG 3 antenna is recommended for the MPR 2.4 reader. See Antenna Specifications, page 230 for more details. Figure 2-3 shows an illustration of the IAG 3 antenna, the recommended antenna for the Multi-protocol Reader.

Figure 2-3: IAG 3 Antenna

Module Descriptions

Smart Multi-protocol RF Module (MRFM-S)	
Function	<p>Executes frame functions triggered by command or configuration messages and timing signals received from the CTM via the DSM.</p> <p>Executes the over-air aspects for a protocol within each frame, generating the analog RF signal that is sent to the OBU via the antenna.</p> <p>Receives the analog RF signal collected from the OBU via the antenna and recovers the data content from the over-air protocol messages.</p> <p>Reports the recovered data and status information as messages that are sent to the CTM via the DSM.</p> <p>Output Power = 33dBm ± 0.6dBm</p>
Units per Reader	One MRFM-S for each antenna. A maximum of 8 MRFM-S per Reader.
Redundant	No
Normal State	The DATA LED 1 illuminates solid green when RF is being transmitted.
Connections	<p>The MRFM-S module supports bi-static output configurations.</p> <p>In bi-static output configurations, both connections 2 and 3 are each connected by an RF cable to the antenna.</p>

The diagram shows the physical layout of the MRFM-S module. At the top is the 'kapsch >>>' logo. Below it are two antenna ports labeled 'ANTENNA' and 'RX'. To the right of the antenna ports is a 'DATA' LED labeled with a circled '1'. Below the antenna ports are two RF connection points labeled '2' and '3'. A warning label at the bottom of the module reads: 'WARNING DISCONNECT RF CABLES BEFORE REMOVING MODULE'.

Smart Multi-protocol RF Module Plus (MRFM-S Plus)	
Function	<p>Executes frame functions triggered by command or configuration messages and timing signals received from the CTM via the DSM.</p> <p>Executes the over-air aspects for a protocol within each frame, generating the analog RF signal that is sent to the OBU via the antenna.</p> <p>Receives the analog RF signal collected from the OBU via the antenna and recovers the data content from the over-air protocol messages.</p> <p>Reports the recovered data and status information as messages that are sent to the CTM via the DSM.</p> <p>Output Power = 36dBm ± 1dBm</p>
Units per Reader	One MRFM-S Plus for each antenna. A maximum of 8 MRFM-S Plus per Reader.
Redundant	No
Normal State	The DATA LED ❶ illuminates solid green when RF is being transmitted.
Connections	<p>The MRFM-S Plus module supports mono static output configurations.</p> <p>Only connection ❷ is connected by an RF cable to the antenna.</p>

Distributions Module (DSM) and Rack	
Function	The DSM is the back plane of the Reader rack.
Units per Reader	One DSM and one Rack
Connections	<p>The MRFM-S (Plus), PSM, LPM, CTM, and SPM modules slide into the Rack and connect to the DSM.</p> <p>The CFMs attach directly to the DSM.</p>

Configuration Module (CFM)	
Function	Stores the Reader configuration file so that the Reader configuration is retained when the CTMs fail or are removed.
Units per Redundant Reader	One CFM on the secondary side 1 , One CFM on the primary side 2
Connections	The CFMs attach directly to the DSM in the secondary location 1 and the primary location 2 . CFMs should not be swapped between readers or within the reader.

Configuration Module

Control Module (CTM)							
<p>Function</p> <p>Contains the Reader processor (MC), the Channel Group Controller module (CGC). Combined these control the operation of the RF modules.</p> <p>CTM ON/OFF switch ⑦</p>	<p>The diagram shows the front panel of the CTM control module. At the top, there are two status LEDs: 'CGC MC' and 'SYNC ACTIVE STATUS'. Below these are two Ethernet ports: 'ETHERNET 1 - 1 Gbps' and 'ETHERNET 2 - 1 Gbps'. A 'POWER' indicator and an 'ON/OFF' switch are located below the Ethernet ports. A 'DIAGNOSTIC PORT' is positioned below the switch. At the bottom, there are four USB ports labeled 'USB 1', 'USB 2', 'USB 3', and 'USB 4'. A 'CTM' label is at the very bottom. Numbered callouts 1 through 9 point to: 1. Ethernet 1 port, 2. Ethernet 2 port, 3. Diagnostic port, 4. USB 4 port, 5. USB 3 port, 6. USB 2 port, 7. ON/OFF switch, 8. Power LED, 9. SYNC ACTIVE STATUS LED.</p>						
<p>Units per Redundant Reader</p> <p>One CTM on primary side, One CTM on secondary side</p>							
<p>Normal State</p> <p>The POWER LED ⑧ illuminates green when the CTM is on and is receiving power from the PSM.</p> <p>The STATUS LEDs ⑨ illuminate green to indicate SYNC is functional, CTM is active, CGC is functional and MC is functional.</p> <p>See Table 6-1 for more information on CTM LED indicators.</p>							
<p>Connections</p>	<table border="1"> <thead> <tr> <th>Port</th> <th>Function</th> </tr> </thead> <tbody> <tr> <td>ETHERNET 1 - 1 Gbps ①</td> <td>Multiple functions, including connecting to external Ethernet lane controllers; connecting a service laptop for initial reader set-up.</td> </tr> <tr> <td>ETHERNET 2 – 1 Gbps ②</td> <td>For connecting several Readers together to create an Inter-Reader (IR) network, or for connecting a service laptop when Ethernet 1 is connected to the Lane Controller.</td> </tr> </tbody> </table>	Port	Function	ETHERNET 1 - 1 Gbps ①	Multiple functions, including connecting to external Ethernet lane controllers; connecting a service laptop for initial reader set-up.	ETHERNET 2 – 1 Gbps ②	For connecting several Readers together to create an Inter-Reader (IR) network, or for connecting a service laptop when Ethernet 1 is connected to the Lane Controller.
Port	Function						
ETHERNET 1 - 1 Gbps ①	Multiple functions, including connecting to external Ethernet lane controllers; connecting a service laptop for initial reader set-up.						
ETHERNET 2 – 1 Gbps ②	For connecting several Readers together to create an Inter-Reader (IR) network, or for connecting a service laptop when Ethernet 1 is connected to the Lane Controller.						

Control Module (CTM)		
	DIAGNOSTIC PORT ③	Serial port access to the reader, intended for Kapsch service use.
	I/O ④	Reserved for future use.
	Port	Function
	USB 1- USB 2 ⑤	Can be used to plug in a USB flash drive, and transfer reader logs to it. Note: only USB drives recognized by the reader's operating system will work.
	USB 3 – USB 4 ⑤	

CTM MC

The MC is a single-board computer that runs the Reader software. The MC is mounted in the CTM.

CTM CGC

The CGC handles the communications between the MC and the RF modules. It also handles the serial communications between the reader and the Lane Controller via the serial connections on the LPM. The CGC is mounted in the CTM.

The CGC hardware supports the following functions.

- Controls the protocol frame timing for each protocol
- Handles inter-reader frame synchronization
- Provides hardware interface for redundancy operation
- Provides hardware interface for supporting up to eight (8) MRFM-S (Plus)
- Provides in-system program capability via the Master interface, for software/firmware and hardware configuration where applicable
- Provides connections for eight serial Lane Controller Ports

Synchronization Port Module (SPM)	
Function	<p>Sends out the status of the Reader (ready or busy) to the other Readers in the synchronization network.</p> <p>Signals to the CTM when all other Readers in the synchronization network are ready.</p> <p>Allows the switchover mode to be set to SECONDARY—AUTO—PRIMARY by the Redundancy Mode switch 2 on the SPM.</p>
Units per Redundant Reader	One
Normal State	N/A (no status indicators on module)
Connections	<p>The SPM terminal block 1 is connected to the other Readers in the synchronization network via the sync terminal block hub.</p>

CGND	1
R-	2
R+	3
T+	4
T-	5
CGND	6

Lane Port Module (LPM)	
Function	Provides 8 serial interfaces between the LCs and CTM. When a reader is initially ordered it can be configured as RS-232 or RS-422 serial connection. It is not field switchable.
Units per Redundant Reader	One LPM on primary side, One LPM on secondary side
Normal State	N/A (no status indicators on module)
Connections	The Reader can send real-time OBU transactions to the LCs via the eight serial ports 1 on the LPM. The LC can also update the Reader configuration via these ports.

1

Power Supply Module (PSM)	
Function	<p>Provides DC power to the modules in the Reader rack.</p> <p>Allows each side (primary or secondary) to be powered on and off via a power switch 2.</p>
Units per Redundant Reader	<p>One secondary PSM on the secondary side</p> <p>One primary PSM on the primary side</p> <p>The secondary and primary PSMs are not interchangeable since they are mirror images of each other. The secondary PSM is keyed to insert in the leftmost rack slot and the primary PSM is keyed to insert in the rightmost rack slot.</p>

Power Supply Module (PSM)	
<p>Normal State</p>	<p>A +15V STATUS LED 4 illuminates green to indicate that 15V DC is being supplied to the Reader.</p> <p>A +5V STATUS LED 5 illuminates green to indicate that 5V DC is being supplied to the Reader.</p>
<p>Connections</p>	<p>A power cable plugs into a socket 1 to supply 115 to 230VAC to the PSMs. Each PSM is equipped with a replaceable 10A fuse 3.</p>

The diagram shows two PSM units side-by-side. The left unit is labeled 'PSM - SECONDARY' and the right unit is 'PSM - PRIMARY'. Both units feature a power input socket (1), a 10A 250V fuse (3), and two status LEDs: a +15V LED (4) and a +5V LED (5). The top of each unit has a 'Kapsch' logo and a 'STATUS' label. Below the LEDs are labels for '+15V' and '+5V'. Safety warnings and cautions are printed on the front panel of each unit.

Ethernet Switch Module (ESM) (Optional)	
Function	<p>Can connect an IR network with up to three Readers for Open Road Tolling (ORT) applications via the Ethernet 2 port on the CTMs. The IR network is used to improve the accuracy of the voting that determines the lane assignment between Readers covering adjacent lanes.</p> <p>Can connect an LC network with all Readers to a Lane Controller and host computer via the Ethernet 1 port on the CTMs. The host computer can be used to access the browser interface for each Reader CTM in the network. The Ethernet switch Module, if used, shall be mounted in a reader cabinet.</p>
Units per Redundant Reader	Two per Ethernet network
Normal State	See the manufacturer’s documentation for details.
Connections	See the manufacturer’s documentation for details.

Reader web interface



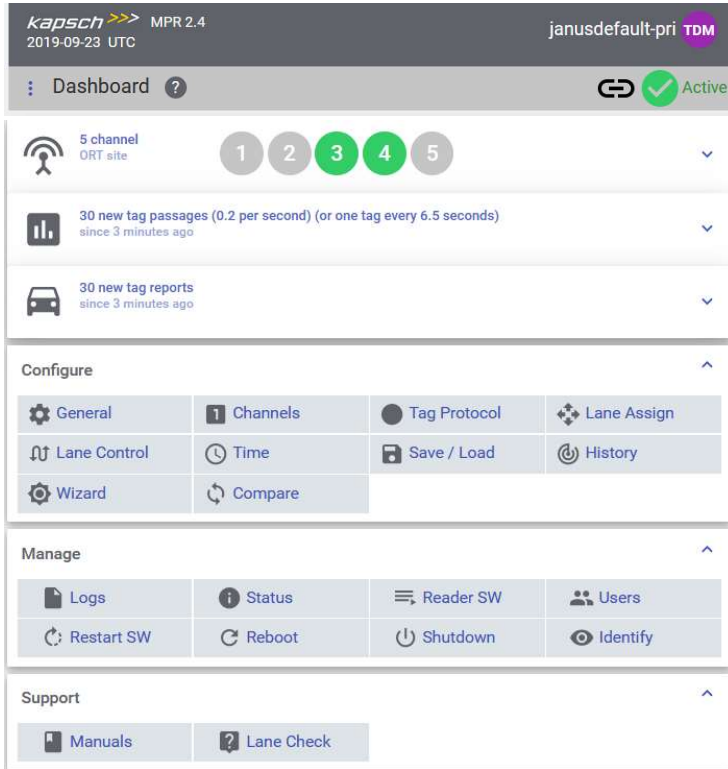



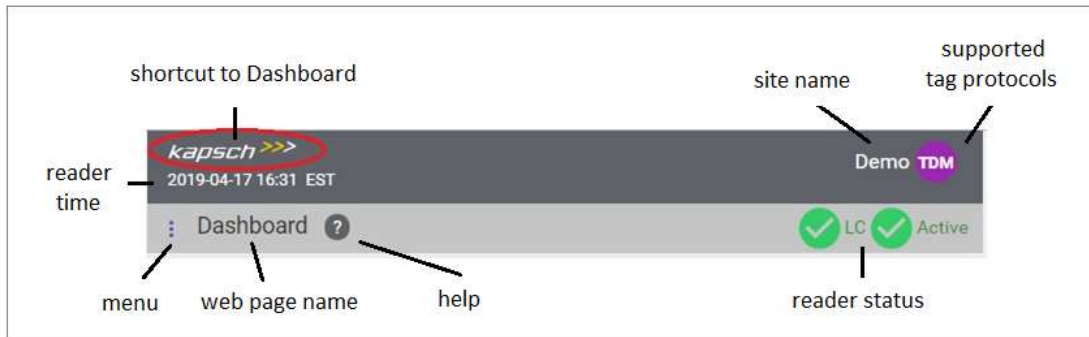





You can use a service laptop with a web browser to access the reader web interface. After logging in, the reader home page (dashboard) is shown, sample below.



The banner at the top of each web page provides the reader status and menu for navigating to commonly accessed pages.



Clicking on the results in the menu being displayed, as shown below:

	Dashboard
	Status
	Logs
	General
	Channels
	Tag Protocol
	Lane Assignment
	Lane Controller
	Time
	Save / Load Configuration
	Reader Software
	Log Out user admin

The menu provides the following options:

Table 2-1: Reader menu summary

Item	Description
Dashboard	The dashboard panel provides a live view of transactions, handshake chart, RF module status, and links to other pages for reader configuration and management.
Status	Show reader status including state of communication links, power supply, RF modules, and transaction buffering.
Logs	Select to access reader log files that includes Tag Transaction logs, Event logs, Trouble logs, NTP and Dev logs.
General	Select to access general settings including Network, SNMP, and switch-over settings.
Channels	Select to access channel state, voting time, and tag timeout settings.
Tag Protocol	Select to access the configuration on Frame and Firing Sequence, TX and RX attenuation, Protocol Frequency, Tag Programming and Advanced options.

Lane Assignment	Select to access the configuration on Lane Assignment algorithm, Inter-reader, TDM Low and Early Read logic.
Lane Controller	Select to access the configuration on Lane Controller interface, Destination and Reporting modes
Time	Select to set Reader Date, Time and Time Zone, Network Time Protocol settings.
Save / Load	Select to manage Reader Configuration, upload, download as well as reset reader configuration to defaults.
Reader Software	Select to view current software version or update reader software.
Log out	Select to quit session and log out of the system.

3. OPERATING PROCEDURES

CAUTION:



Improper modification of configuration parameters may adversely affect system operation. The default values may not be appropriate for the specific application. It is the system integrator's responsibility to tailor the configuration parameters to the specific operating environment, with the aid of the Kapsch Operations Group.

CAUTION: Redundant Reader



Both CTMs in a redundant Reader must be properly configured. Each CTM has its own browser interface and is configured independently, unless Configuration Alignment is enabled. If Configuration Alignment is not enabled, ensure any configuration changes made to one CTM are applied to the other CTM, as required.

Starting up the Reader

This procedure outlines the correct way to power on and boot up a Reader.

Prerequisites: PSM power switches set to the off (0) position.

1. CTM ON/OFF switches set to OFF.
2. Set the **Redundancy Mode** switch on the SPM to **AUTO**.
3. Set the secondary and primary PSM power switches to the **on (I)** position.

Result: The +15V STATUS LED and the +5 STATUS LED on the PSMs illuminate solid green.

4. Set the CTM ON/OFF switch to the ON position, and wait for the CTM to complete its power up cycle, when the Primary side ACTIVE indicator becomes green (typically less than 90 seconds). At this point the reader is able to process tag reads.

Result: The POWER LED illuminates green. The MC indicator should blink green to indicate the reader software is running. The CGC indicator should be solid green. The ACTIVE indicator should be green on the Primary side.

Note: If any CTM STATUS LEDs indicate an abnormal state, (see Table 6-1: CTM LED states explained on page 185) perform the necessary troubleshooting procedure. See Troubleshooting Methodology on page 183 for more information.

Connecting a service laptop to the Reader

You can use a service laptop to access the reader web interface by connecting an Ethernet cable directly to the CTM front panel ETHERNET 1 or 2 interface.

Determine the Reader IP address

Determine the last known IP address the reader was set to. During setup, it is typical for the IP address to be changed to reflect the local LAN configuration. Consult the record of system IP addresses to determine the correct IP address.

The factory default IP address of the primary and secondary ETHERNET 1 port is **192.168.1.50**.

It is expected that the reader ETHERNET 1 IP address be changed to non default values. Do not connect both Primary and Secondary CTMs to a local LAN without first changing one or both of the default IPs.

As an option, you can also connect via the ETHERNET 2 interface at its default address of 192.168.0.50 (primary side), or 192.168.0.51 (secondary side) if that interface is not in use.

Changing the service laptop address

1. To connect a laptop directly to the reader via an Ethernet cable, it must be on the same subnet as the reader. This means the laptop's Ethernet interface settings are temporarily changed to allow a connection with the reader.
2. In Windows, click on the Windows icon, then type in "control panel" and Enter. In the Control Panel, click on **Network and Sharing Center**. Click on **Change adapter settings**. Right click on the Ethernet interface used to connect to the reader, and click on **Properties**. Scroll to **Internet Protocol Version 4** and click on **Properties**. Select **Use the following IP address**, then enter an IP address that is on the same subnet as the reader; for example you could set the laptop IP address to **192.168.1.99**. Enter 255.255.255.0 in the subnet mask and leave the default gateway blank.

(Optional) Testing the connection to the reader

This procedure can help you troubleshoot a new connection.

1. In Windows, open a command line window. There are various ways of doing this depending on the version of Windows. For Windows 10/Windows 7, one method is to click the Windows icon, then type in **cmd** and Enter. This should open a command prompt window.
2. Within the command window, type 'ping', the space character, followed by the reader IP address determined above. If the connection to the reader is working, you should get "Reply from" messages indicating that the reader connection is good. Typically ping times are less than a few milliseconds. If you are not getting a response (e.g. "request timed out"), then you need to troubleshoot the connection. Check the cable, connections, and the reader IP address used.
3. To exit the cmd window, type "exit" and ENTER.

Accessing the Reader web interface

The reader web interface is used to view and change configuration settings, examine logs, update reader software, and check on reader operation.

Prerequisites: A service laptop connected to one of the front panel Ethernet ports. Refer to Connecting a service laptop to the Reader, page 43.

1. Launch a web browser on the service laptop. **Note:** Please use a recent version of Chrome, Firefox, or the Edge browser. Other browsers may work, but are not tested for compatibility.
2. In the address bar of the web browser, type: https:// followed by the reader IP address (e.g. https://192.168.1.50). Note the “s” in “https”.

Use the following decision table to continue the procedure.

IF ...	THEN ...
the browser shows the reader login page requesting a username and password,	go to step 4.
a "Unable to Connect," or "refused to connect" message appears,	ensure the IP address entered in the address bar is correct and that the IP address is preceded by https:// Note: When you connect to the Reader for the first time accept the reader certificate before continuing.
a web browser message indicating there is a connection problem appears,	confirm that the IP address entered in step 2 is correct
a security warning appears	This is expected the first time you connect; follow the instructions to accept the reader certificate.

3. Enter your reader username and password. The default reader integrator account is "admin", password "admin". Usernames and passwords are case-sensitive.
4. Click the log in button.

Result: The reader Dashboard (home page) should appear. Sample screenshot.

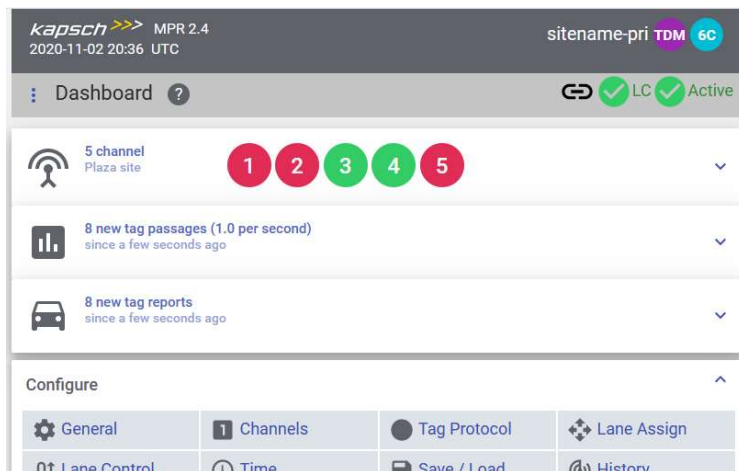

Shutting down the Reader

CAUTION:



A reader shutdown should not be done remotely (i.e. you should be on-site), as the only way to restart the reader is with a power cycle.

To shut down one side of the reader:

1. From the home page, click on the Shutdown  link. If a secondary CTM is also being shut down in parallel, you can open a 2nd browser window to the secondary CTM and apply the same procedure in parallel.
2. Confirm the shutdown (click the YES button).
3. Wait 5 seconds after the front panel indicators have turned off, then set the CTM ON/OFF switch to OFF.
4. Set the PSM power switch to the off (0) position.
5. Repeat on the other CTM if it also requires to be shut down.

Manually switching a Reader to the redundant side

The Reader can be manually switched between the primary and secondary sides. This can be used during reader setup for example, to confirm tag reporting from the Secondary CTM.

Prerequisites: Ensure no faults exist on the side being activated.

1. Set the SPM redundancy mode switch to either SECONDARY or PRIMARY, as applicable.

Result: The ACTIVE indicator on the CTM of the selected side illuminates green, indicating the selected side is active.

Note 1: If the redundancy mode switch is set to PRIMARY, the primary side is active and does not switch operation to the secondary side unless the primary side fails.

Note 2: If the switch is set to SECONDARY, the secondary side is active and does not switch operation to the primary side unless the secondary side fails.

Note 3: The redundancy mode switch should be restored to the AUTO position on a redundant reader, under normal operations.

Logging out of the web interface

Logging out of the web interface ends the session for the current user on that side of the reader. Note that the reader will also end the session automatically after a period of inactivity.



1. In the web interface banner, click on the menu icon , and select **Log Out**.
2. Select "YES" when the log out confirmation dialog appears.

Result: You are immediately logged out from that side of the reader. Repeat on the other side if need be.

Changing your password

You can change your web account password with this procedure.

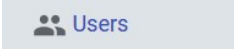
Prerequisites: Accessing the Reader web interface, page 43.

1. From the reader dashboard, select the Users page. 
2. Select your user name from the user table and select Change Password () icon
3. Enter your new password in the Password and retype password fields.
4. Click the SAVE button.

Result: Your password is now changed. Repeat on the secondary side.

Resetting a forgotten password

If a user forgets their password, the password can be cleared by another user with **Admin User** permissions. This procedure requires two users; a user with **Admin User** permissions and the user requiring a reset password.

Prerequisites: The user clearing the password must have **Admin User** permissions.

1. Have an admin user log in and navigate to the **Users** page.
2. Select a user listed in the table whose password is to to reset.
3. Click the corresponding Reset Password () button and then YES to confirm.

Result: The locked out user's password is reset to "password"

4. Log out (see Logging out of the web interface, page 46).
5. Have the locked out user try to log in, now with a password of "password".
6. Immediately change your password (see Changing your password, page 46).

Checking Reader Status

You can monitor and gather information about the Reader from the web interface. From the reader home page, click on the **Status** to get to the status page. The Status page displays the state of the communication links, the power supply modules, and the CTM/CGC, and is useful for troubleshooting the Reader. The Status page is divided into a number of panels.

Communications Status

The first panel indicates the Communication status, as shown below.

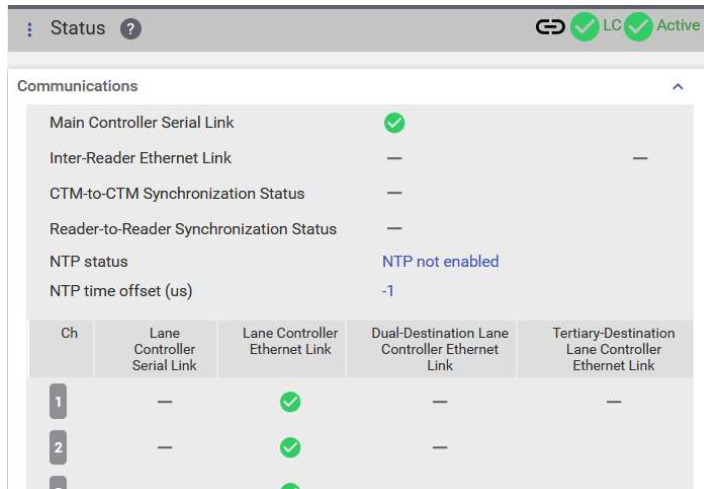



















Table 3-1 lists and describes the fields in the Communications panel of the Status page.

Table 3-1: Communications fields

Communications panel		
Field	Status	Description
Main Controller Serial link		successful link connection between redundant CTMs
		link failure or disabled (always Down on non-redundant Readers)
Inter-Reader Ethernet link		Inter-Reader link is up
		Inter-Reader link is down
		link not enabled

Communications panel		
Field	Status	Description
Lane Controller Serial link		successful serial connection to LC
		link is down
		link not enabled
Lane Controller Ethernet link		successful connection to LC
		link is down
		link not enabled
Dual-Destination Lane Controller Ethernet Link		successful link connection
		link is down
		link not enabled
Tertiary-Destination Lane Controller Ethernet Link		successful link connection
		link is down
		link not enabled
CTM-to-CTM Synchronization Status		Inactive side not in sync
		Inactive side in sync
Reader-to-Reader Synchronization Status		successful link connection
		link failure
		Synchronization not enabled

Power Supply status panel

Table 3-2 lists and describes the fields in the Power Supply panel of the Status page.

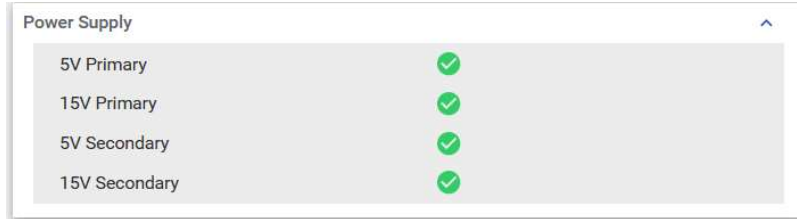

Table 3-2: Power Supply status fields

Power Supply status		
Field	Status	Description
All power supply fields		DC input operational
		DC input failure

RF Modules

Table 3-3 lists and describes the fields in the RF Modules panel of the Status page.

	Module Presence	Firmware Version	Comm. Status	Antenna Status
1		2017May12-1033-04		
2	—	?	?	?
3	—	?	?	?
4	—	?	?	?
5	—	?	?	?

Note the RF Module status on the inactive CTM of a redundant reader may not always reflect the current module status. Always refer to the active side for RF Module status.

Table 3-3: RF Modules fields

RF Modules panel		
Field	Status	Description
Module Presence		Not installed
		Installed

		Status not known
Firmware Version	yyymmdd- xxxx-xx	Firmware date
		Status not known
Comm Status		RF module is communicating
		RF module communication failed, or RF module removed.
		Receiving and/or transmitting
Antenna Status		Fault in receiving and/or transmitting
		Status not known

Reader Status panel

Table 3-4 lists and describes the fields in the Reader Status panel on the Status page.

Reader Status	
CTM Position :	Primary
Active State :	
Other side CTM Presence :	
Other side Config Compare :	
Front-panel Switch Position :	Auto
Frame Seq. Config :	
Super Frame Time (w. overhead, us) :	16390
CPU Load :	
Uptime (seconds) :	264740
USB Logging Status :	Not Detected

Table 3-4: Reader Status fields

Reader Status panel		
Field	Status	Description
CTM Position	Primary	CTM is installed on the primary side
	Secondary	CTM is installed on the secondary side
Active State		CTM is active
		CTM is not active
Other Side CTM Presence		The other side CTM is present in the chassis.
		The other side CTM is not present in the chassis.
Other Side Config Compare		Communication Down (peer CTM is not running so configuration state is unknown)
		Same (peer CTM configuration is identical to this CTM's configuration)
		Different (peer CTM configuration is different than this CTM's configuration)
Front-panel switch position	Auto; Primary; Secondary	Auto, Primary (switch set to Primary side), Secondary (switch set to Secondary side). For a redundant system, the switch would normally be set to Auto
CFM Status	Present	Indicates normal status
	Not Detected	Indicates a problem; call Kapsch Service
Frame Seq. Config.		Indicates whether or not the last attempted frame sequence configuration contains errors. If an error is indicated, review the Tag Protocol configuration, and review the event/trouble logs for more detailed information.
Super Frame Time (µs)	e.g. 18375	Reader timing information (frame sequence length) In microseconds
CPU Load 		CPU load is normal.
		CPU load is High (above 50%)

Reader Status panel		
Field	Status	Description
		CPU load is Extreme (above 80%)
Uptime 	Uptime value	Number of seconds since power up.

Transaction Buffering panel

This panel on the Status page shows how many reports are buffered for each channel. The reader buffers tag reports in its memory when a lane controller connection is down. The following screen shows an example.

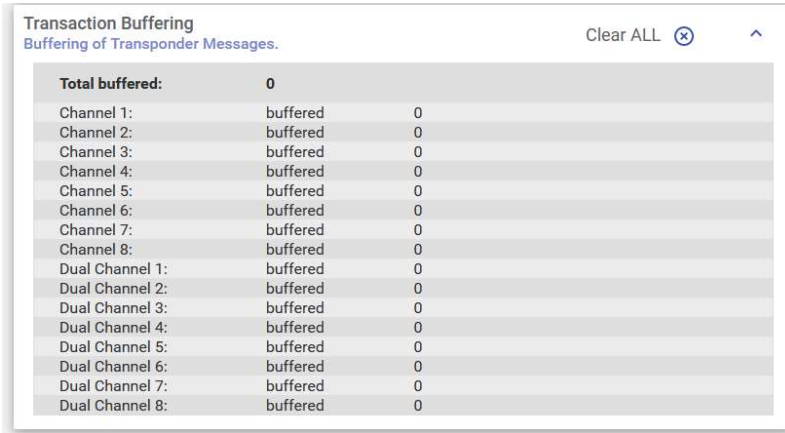

Configuring the Reader

Prerequisites: Connecting a service laptop to the Reader, page 43.

View or modify reader configuration settings from the Dashboard page, using the buttons in the Configure panel (sample shown below).

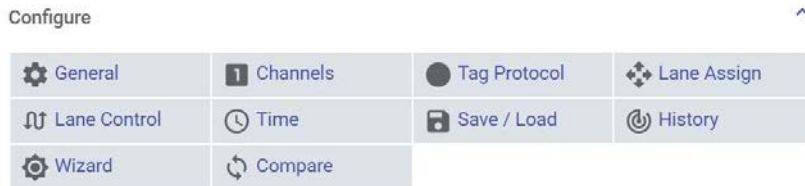

A list of settings available and their function is provided in **Commands and controls**, see page 75.

Each configuration button links to a configuration page listed in Table 3-5. It is recommended that the following configuration pages be reviewed:

- Time
- General
- Channels (“tag timeout” parameter is on this page)
- Tag Protocol
- Lane Controller
- Lane Assignment

The  icon at the top of any reader web page, indicates the current user account has **read-only** access to the configuration settings. In this mode, the user can view but is not able to change configuration settings.

Table 3-5: Reader Configuration pages

Button	Function																
General	<p>Configure site information, reader network settings, SNMP, and switch-over settings.</p> 																
Channels	<p>Configure RF module state (Active, Offline, Guard, NoModule).</p>  <table border="1" data-bbox="511 1428 1242 1648"> <thead> <tr> <th>Ch</th> <th>RF State</th> <th>Voting Time (ms)</th> <th>LPT/FME Voting Time (ms)</th> </tr> </thead> <tbody> <tr> <td>1</td> <td>Active</td> <td>100</td> <td>300</td> </tr> <tr> <td>2</td> <td>Active</td> <td>100</td> <td>300</td> </tr> <tr> <td>3</td> <td>Active</td> <td>100</td> <td>300</td> </tr> </tbody> </table>	Ch	RF State	Voting Time (ms)	LPT/FME Voting Time (ms)	1	Active	100	300	2	Active	100	300	3	Active	100	300
Ch	RF State	Voting Time (ms)	LPT/FME Voting Time (ms)														
1	Active	100	300														
2	Active	100	300														
3	Active	100	300														
Tag Protocol	<p>Set up which tag protocols are in use, their time slot and reader sync. You can also set the frequency (where applicable) and attenuation.</p>																

	<table border="1"> <thead> <tr> <th>Ch</th> <th>Rx Attenuation (dB)</th> <th>Tx Attenuation (dB)</th> <th>Frequency (MHz)</th> <th>Time Slot</th> </tr> </thead> <tbody> <tr> <td>1</td> <td>5</td> <td>0</td> <td>915.75</td> <td>...</td> </tr> <tr> <td>2</td> <td>5</td> <td>0</td> <td>915.75</td> <td>...</td> </tr> </tbody> </table>	Ch	Rx Attenuation (dB)	Tx Attenuation (dB)	Frequency (MHz)	Time Slot	1	5	0	915.75	...	2	5	0	915.75	...
Ch	Rx Attenuation (dB)	Tx Attenuation (dB)	Frequency (MHz)	Time Slot												
1	5	0	915.75	...												
2	5	0	915.75	...												
<p>Lane Assignment</p>	<p>View and modify inter-reader voting settings, and other settings for improving lane assignment.</p>															
<p>Lane Control</p>	<p>Configures the lane controller endpoints (destinations) and which reader events are reported. By default only the Vote report is generated.</p>															

<p>Time</p>	<p>Set the reader time manually or via NTP.</p>																																				
<p>Save/Load</p>	<p>Allows reader configuration to be saved, loaded or reset to defaults.</p>																																				
<p>History</p>	<p>Show recent history of configuration changes.</p> <table border="1"> <thead> <tr> <th>Time changed</th> <th>Parameter</th> <th>Set to</th> <th>By</th> </tr> </thead> <tbody> <tr> <td>2020-11-02 15:53:41</td> <td>Sequence (1-10) FRSEQ1[1]</td> <td>Empty</td> <td>WEB2_</td> </tr> <tr> <td>2020-11-02 15:53:40</td> <td>Reader-to-Reader Sync. Enable RFSYNC[0]</td> <td>0</td> <td>WEB2_</td> </tr> <tr> <td>2020-10-30 19:46:28</td> <td>Network Time Protocol NTP__[0]</td> <td>Disable</td> <td>WEB2_</td> </tr> <tr> <td>2020-10-30 19:34:05</td> <td>Dynamic Voting Control DVCTRL[4]</td> <td>Reader</td> <td>WEB2_</td> </tr> <tr> <td>2020-10-30 19:31:49</td> <td>Dynamic Voting Control DVCTRL[2]</td> <td>Reader</td> <td>WEB2_</td> </tr> <tr> <td>2020-10-30 19:31:17</td> <td>TDM Tx Attenuation (dB) TA6TX1[3]</td> <td>20</td> <td>WEB2_</td> </tr> <tr> <td>2020-10-30 19:31:15</td> <td>TDM Tx Attenuation (dB) TA6TX1[2]</td> <td>20</td> <td>WEB2_</td> </tr> <tr> <td>2020-10-30 18:56:47</td> <td>NTP Server 1 NTP__[1][0]</td> <td>0.0.0.0</td> <td>WEB2_</td> </tr> </tbody> </table>	Time changed	Parameter	Set to	By	2020-11-02 15:53:41	Sequence (1-10) FRSEQ1[1]	Empty	WEB2_	2020-11-02 15:53:40	Reader-to-Reader Sync. Enable RFSYNC[0]	0	WEB2_	2020-10-30 19:46:28	Network Time Protocol NTP__[0]	Disable	WEB2_	2020-10-30 19:34:05	Dynamic Voting Control DVCTRL[4]	Reader	WEB2_	2020-10-30 19:31:49	Dynamic Voting Control DVCTRL[2]	Reader	WEB2_	2020-10-30 19:31:17	TDM Tx Attenuation (dB) TA6TX1[3]	20	WEB2_	2020-10-30 19:31:15	TDM Tx Attenuation (dB) TA6TX1[2]	20	WEB2_	2020-10-30 18:56:47	NTP Server 1 NTP__[1][0]	0.0.0.0	WEB2_
Time changed	Parameter	Set to	By																																		
2020-11-02 15:53:41	Sequence (1-10) FRSEQ1[1]	Empty	WEB2_																																		
2020-11-02 15:53:40	Reader-to-Reader Sync. Enable RFSYNC[0]	0	WEB2_																																		
2020-10-30 19:46:28	Network Time Protocol NTP__[0]	Disable	WEB2_																																		
2020-10-30 19:34:05	Dynamic Voting Control DVCTRL[4]	Reader	WEB2_																																		
2020-10-30 19:31:49	Dynamic Voting Control DVCTRL[2]	Reader	WEB2_																																		
2020-10-30 19:31:17	TDM Tx Attenuation (dB) TA6TX1[3]	20	WEB2_																																		
2020-10-30 19:31:15	TDM Tx Attenuation (dB) TA6TX1[2]	20	WEB2_																																		
2020-10-30 18:56:47	NTP Server 1 NTP__[1][0]	0.0.0.0	WEB2_																																		

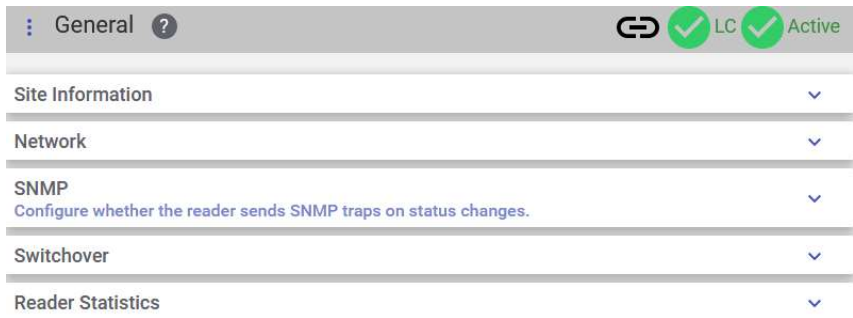
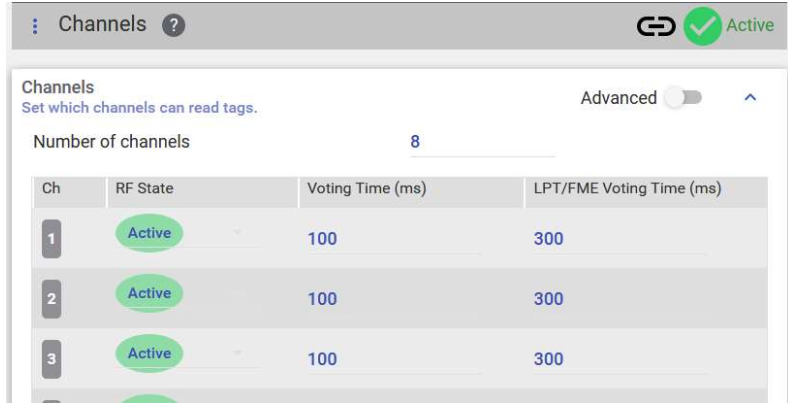
<p>Wizard</p>	
<p>Compare</p>	<p>Refer to Configuration Alignmentt, page 71.</p>

Using the Reader Setup Wizard



The Setup Wizard can help less experienced operators set up a new Reader.

NOTE: If the configuration alignment icon is shown in the banner , both primary and secondary sides of the reader are configured with the same settings; i.e. there is no need to repeat the Wizard on the Secondary side of the reader. Note that you will need to configure a small subset of unique settings (see Configuration Alignment, page 71).

1. Start the Wizard from the Primary side of the reader, from the Dashboard page, via the Wizard button.

Enter the Site Name. Avoid adding any Primary or Secondary side designation within the site name, as the reader automatically adds a “-pri” or “-sec” suffix in logs and in the banner. The same site name will be applied to the secondary side.

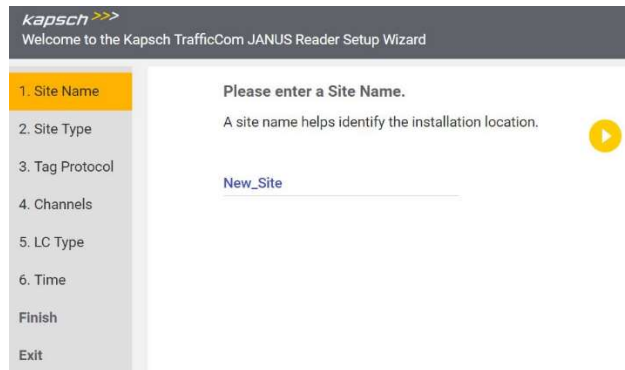

Select the site type. This sets an initial voting time, which is used to determine when the reader generates a passage (VOTE) report to the lane controller.

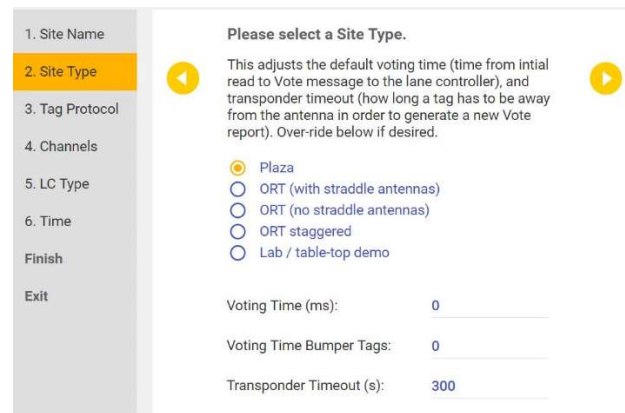

The next wizard page is used to select which tag protocols are enabled. Select all required tag protocols (click on the + icon to add items). You can enable reader sync here as well by adding a "Sync" item. Any power (Tx Attn) or

sensitivity (Rx Attn) settings will be applied as a baseline to all channels for that particular protocol, which can be adjusted individually after the wizard exits.

Please select the tag protocols.

Protocol	Rx Attn	Tx Attn	Freq
TDM	5	0	915.75
+	5	0	902.50

Protocol To add a protocol, or enable reader sync, click the + sign and select an item. The TDM protocol is enabled by default.

Rx Attn Enter a number to specify each channel's receive attenuation (in dB). A value of 0 means full sensitivity.

Tx Attn Enter a number to specify each channel's transmit attenuation (in dB). A value of 0 means full power. For lab testing with a patch antenna, try 15.

Freq For passive protocols, specify the starting frequency for channel 1. The wizard automatically assigns 2.5 MHz channel spacing for adjacent channels. For TDM protocol the frequency is fixed.

Note: Independent configuration for all channels can be made after the wizard exits.

The next wizard page asks for the number of antennas. This is used to reduce the number of settings shown on various web pages. For example selecting 5 antennas will set up the reader for a 5 channel scan, and will hide web interface settings for channels 6, 7, 8. Note: This setting can be adjusted after the wizard exits.

Enter the number of antennas to be configured for this reader.

5

On the next wizard page, select the lane controller Interface type.

Please select the Lane Controller Interface Type.

Specify default settings for Ethernet and Serial.

Ethernet
 Serial
 None

Enter Lane Controller Ethernet IP address and Port number.

IP Address: 192.168.1.50
 Port: 0

On the next wizard page, the time setting method can be specified.

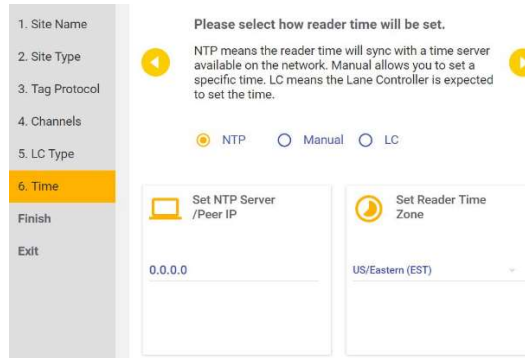

Review the settings.

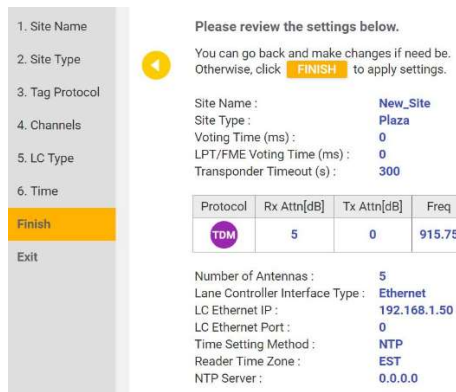

Click **FINISH** to apply the settings.

Channel configuration

The presence or absence of MRFM-S (Plus) modules in the rack and their assigned status is provided by the **Channels** page. Select this page and declare the "RF State" state of each physical slot in the reader. By default, all channels are set to Active. Channel 1 is the leftmost slot in the reader RF rack. Those RF channels that are known to be empty, should be marked on the Channels page as "NoModule" in order to avoid the reader assuming there is a RF module communications fault.

A voting time is specified for each channel, which controls the timing of the "Vote" report to the lane controller. A separate voting time is configurable for bumper mount (LPT/FME tags). There is one Vote report per tag passage to the lane controller, even when cross channel reads occur. Dynamic voting can be enabled (toggle the Advanced slider), which lets the reader chose an optimum voting time for that particular channel based on recent tag traffic in that channel.

Sample "Channels "page:

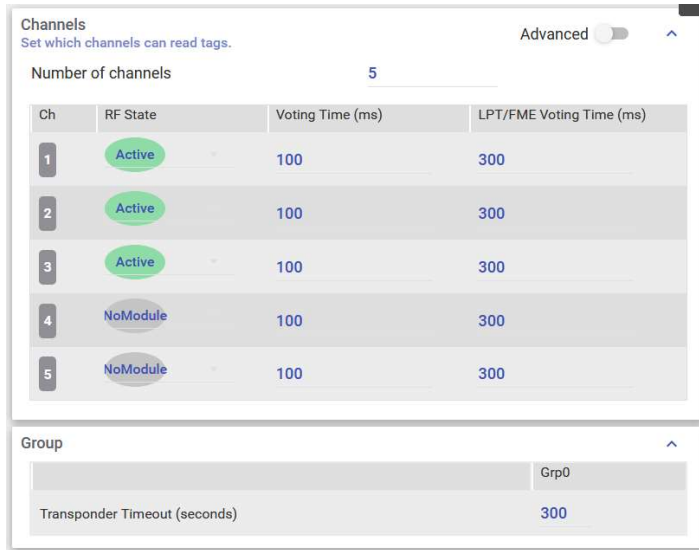

The group panel is where the **Transponder Timeout** parameter is set. This is the period of time (in seconds) after a given transponder’s last read, before the reader can generate a new passage (Vote) report for that same transponder. The default is 300 seconds. If you are doing a table top demo or a parking lot experiment, this value will likely need to be adjusted downward, to perhaps 1 or 2 seconds.

Example reader dashboard with a RF module in slot 1 and 2 present, but none in slots 3, 4, and 5 would indicate the following:

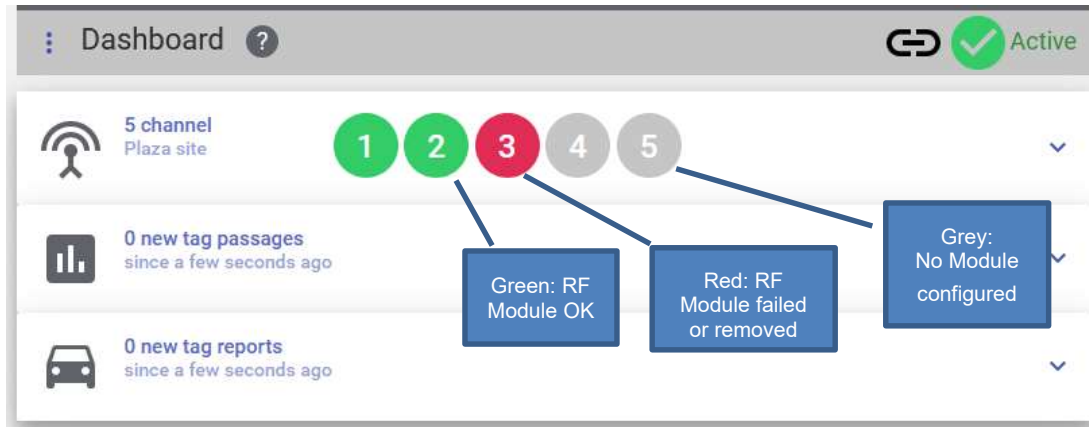

If a transponder is readable by an antenna, the dashboard tag presence indicator (the black arrows) appears to the right of the channel number (sample below). This indicates a tag is reading on the corresponding channel.



Frequency and Time Multiplexing

In any toll site involving multiple simultaneous transmitting antennas either frequency division or time division between adjacent transmitting antennas is required. The required spacing and re-use guidelines are discussed in **Installing a Lane Kit**, page 159 and in Appendix B FCC Approved Channel Frequencies and Selection, page 247, which provides detail on FCC permitted frequencies and ERP.

The TDM time sequence is set in the Tag Protocol page as part of the Multi-Protocol Acquisition Sequence (Frame Sequence), see Multi-protocol tag acquisition sequence building, page 65.

Frequency Selection

Select the **Tag Protocols** page and select a specific protocol icon to show the operating frequency settings for that protocol.

Note1: There must be at least a 2.5 MHz frequency separation between adjacent antennas, either in a single or multi-reader environment.

Note2: The FCC allowed frequencies are RF Module model and protocol specific. See Appendix B for details.

Note3: Typically, the channel operating frequency selected will be the same for all FDM protocols

Note4: The TDM protocol operating frequencies are fixed and cannot be changed

Note5: If the configuration alignment icon is shown in the banner , you only need to change frequency settings on the Primary side of the reader. Any changes are then automatically applied on the Secondary side.

Result: The following screen is shown as an example (6C protocol in a 5 channel configuration).

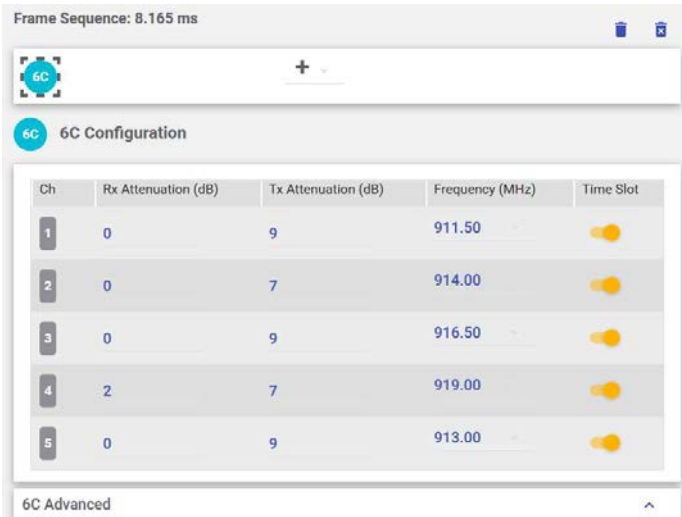

RF Attenuation

The transmit power is adjustable individually by protocol and channel by controlling the Tx (transmit) attenuation setting. Similarly the receive sensitivity can be adjusted individually by protocol and channel by controlling the Rx (receive) attenuation.

Select the **Tag Protocols** page, then one of the enabled protocols in the frame sequence. Then adjust the desired Tx and Rx attenuation for each channel.



Note: If the configuration alignment icon is shown in the banner , any attenuation change made on the Primary is also set automatically on the Secondary side.

Programming tags

For certain tag protocols (TDM and 6C), the Reader can write data to a tag as it passes through a toll collection point. The following procedures outlines how to enable tag programming and how to configure what data fields are written to the tags.

1. Under Tag Protocols, select TDM. Scroll down to the **TDM Tag Programming** panel.

To confirm TDM tag programming is enabled, ensure that "Enable" is toggled on.



To disable TDM tag programming, toggle the slider off.

Configuring TDM tag programming for Traffic Management Applications

1. From the **TDM Tag Programming** panel, select the **Enable TMP** switch position ON.
2. Select the Reader ID switch to enable writing the Reader ID to tags.
3. Enter a unique Reader ID.
4. Select the TM Date/Time switch to write the Reader TM time to tags.

Example: The following screen is shown.

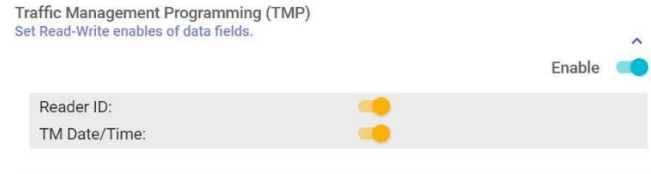

Note: Reader ID is required to support Badger Style CRA operation when there are multiple adjacent readers. This will reduce duplicate tag Vote reports to the lane controller.

Configuring TDM tag programming for Toll Collection applications

1. From the **Toll Collection Programming (TCP)** panel, ensure **Enable** is toggled on.

Result: The following screen appears:



2. Enter the Plaza ID and Agency ID in the fields in the TDM Tag Programming panel.
3. The following fields should be enabled; if not, toggle them on.
 - TC Date/Time
 - R/W Format
 - Lane number
4. Select the OBU Feedback check box to enable OBU (tag) feedback.

(Optional) Assign a Lane Number to each RF channel. When a transaction occurs between an OBU and a channel, the Lane Number specified here will be written to the OBU read/write memory.

Configuring 6C tag programming for Toll Collection applications

The Reader can write data to a 6C tag as it passes through a toll plaza. The following procedure outlines how to enable 6C tag programming and how to configure the data that is written to the tags.

1. In the 6C Programming panel, set the Enable toggle.

Result: The following screen appears:



Configuring OBU Feedback

This setting applies to the TDM Feedback transponder. This tag model has audible and visual (red, green, and yellow) indicators that can be activated by the reader as the transponder crosses an antenna zone. TDM Programming needs to be enabled for this functionality.

1. Toggle the “OBU Feedback” slider in the **OBU Feedback** panel.

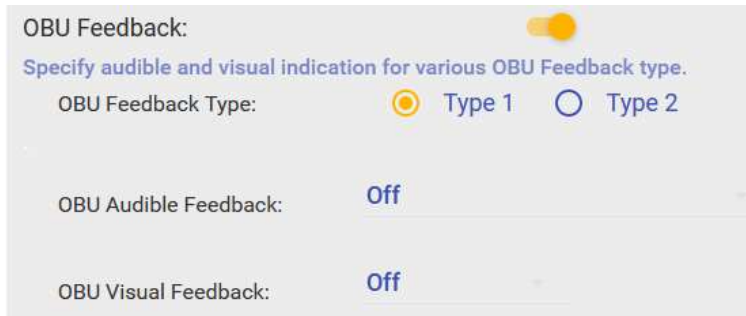

2. Select either Type 1 or Type 2 feedback. Type 1 means that the same feedback is provided to any TDM feedback tag seen by the reader. Type 2 means the reader examines a reader-local Status File to determine what feedback to provide. Each feedback tag can be provided a different feedback according to status settings of the Status File. The Status File must have been previously transferred to each side of the reader.
3. Select the desired audible feedback to control OBU beeping when a transaction occurs.
4. Select the desired visual feedback to control OBU LED flashing when a transaction occurs.

Configuring Reader switch-over events

The Reader can be configured to automatically switch over to the secondary side when certain failures are detected on the primary side. The following table lists the user controllable switch-over events:

Event	Cause	Enabling
Failed Serial Lane Controller Link	<p>The Reader forces a switchover when an enabled serial link from the LPM to the LC has been interrupted. Usually a downed link is due to external conditions.</p> <p>Only the lack of OBU transactions in outgoing messages to the LC allows a downed link to be detected. To detect serial cable issues in the absence of OBU transactions, the operator must enable Serial Heartbeat messages</p>	<p>On the General page, Switchover panel, toggle the Switchover on serial LC link down setting.</p> <p>On the Lane Controller page, LC Serial panel (toggle Advanced to make it visible) review the Send Serial Heartbeats setting.</p>
Failed Ethernet Lane Controller Link	<p>The Reader forces a switchover when an enabled Ethernet link has failed. Usually a downed link is due to external conditions.</p> <p>A downed link is detected regardless of whether OBU transactions are being generated or not.</p>	<p>On the General page, Switchover panel, toggle the Switchover on Ethernet LC link down setting.</p> <p>Reivew the LC Ethernet TCP-Socket Timeout on the Lane Controller page.</p>
Failed Inter-Reader Ethernet Link	<p>The Reader continuously checks the link status of the IR network and forces a switchover if it fails.</p>	<p>On the General page, Switchover panel, toggle the Switchover on Inter-Reader link down setting.</p>

Multi-protocol tag acquisition sequence building

Multi-protocol acquisition sequence building, also referred to as Frame Sequence building, allows the user to customize over the air protocol sequences that a Reader or a network of Readers can use to identify, register, and track multiple protocols in a toll environment.

The modular design approach for multi-protocol acquisition sequences allows for the following specializations.

- Balanced weighting between all protocols regardless of TDM or FDM division
- The inclusion of parallel TDM channel firing sequences.
- Protocol synchronization

The Frame Sequence is configured using the **Tag Protocol** page to define the time order over the air of protocols and other operations, and individual panels for protocols that each define what operations are executed within

that protocol's frame and which channels are employed for that protocol. The Frame Sequence continually repeats over the air.

Note 1: The Frame Sequence defines the repeating protocol time sequence that will be followed by the reader, irrespective of the assigned MRFM-S (Plus) status in the Channel panel.

Note 2 For an RF Module to participate in a protocol it must both be enabled for that protocol in the applicable protocol panel and also set to Active or Guard in the Channel page.

Note 3: It is possible to create a sequence with channels and timeslots assigned for MRFM-S (Plus) that are not populated or active in the reader. This often occurs and is required when synchronizing two readers with different number of channels populated as the time structure of the Frame Sequence needs to be the same on both readers.

Note 4:  For single lane solution where maximum handshake performance is desired, it is possible to set the TDM frame sequence with a single channel.

Note 5:  Frame sequence changes are applied as soon as they are made, i.e. there is no longer a separate "Update Frame Sequence" button (compared to MPR 2.3).

Reader supported protocols

The Reader supports the following protocols.

- TDM
- SeGo
- ISO-6B
- ISO-6C
- ATA

To add or remove protocols from the frame sequence:

1. From the Dashboard page, select  , or as a shortcut, click in the banner on any protocol icon (e.g. ) to navigate directly to that protocol's settings page.

Result: The following screen appears. By default, the reader is set up for reading and writing TDM protocol transponders. Additional protocols can be added by clicking on the "+" icon.

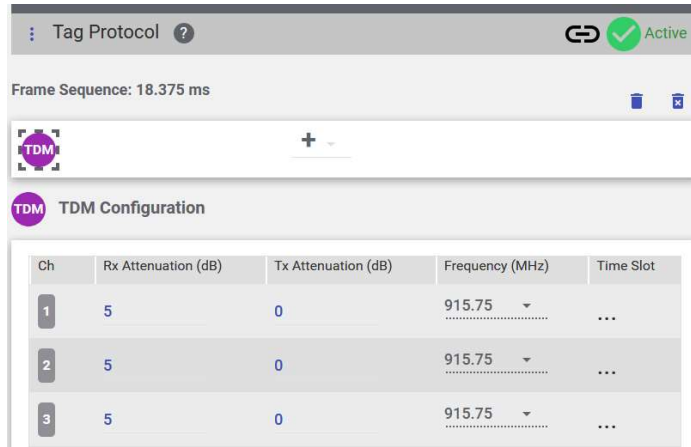

1. Click the **+** to show a list of protocols that can be added. Select the required protocol to be added (example below).

Note: The "Title21" protocol is not currently available, despite it being shown as an option.

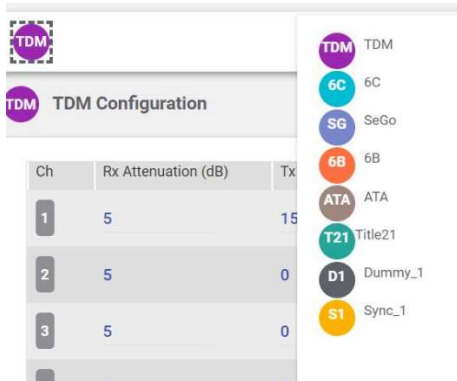

2. Repeat the previous step for each desired protocol to be supported.

Note 1: The maximum number of actively transmitting frames must be kept to 8 or less. Sync frames and Dummy frames (that do not transmit) are not counted.

Note 2: The changes take effect as soon as you make them. Take note of the frame sequence time which updates automatically as you make changes. This gives you an idea of the interval in milliseconds between tag reads for a given antenna. For example, the reader default TDM 8 channel firing sequence results in a frame sequence of 18.375 milliseconds.



3. Review the options available under each protocol type and adjust as required.

4. To delete a protocol, select its icon and click on . To delete all items, click on .

Note: Protocols can be deleted in any order.
5. To enable reader sync, click the + icon and add a element. To disable reader sync, select the sync element and click on .

The following three diagrams show examples of different Frame Sequences that can be created:

Figure 3-1: Example Frame Sequence (Balanced Protocol Weighting)

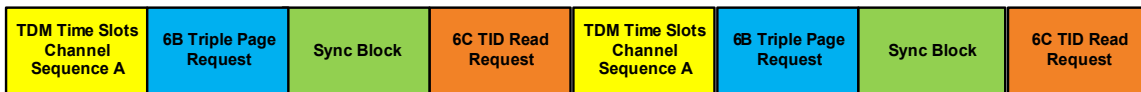

Channel Sequence A
 IAG Read Only
 TDM Slot 1: CH1 + CH5
 TDM Slot 2: CH3
 TDM Slot 3: CH2+CH4
 TDM Slot 4:CH6+ CH7

Figure 3-2: Example Frame Sequence (6B Weighted)



Figure 3-3: Example Frame Sequence with Dummy Frame

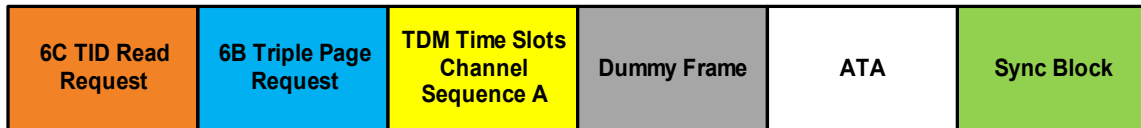

Dummy frame

A dummy frame is a software configurable time interval which can be inserted in the firing sequence. A dummy frame can be configured in one of the following two ways.

- Constant carrier is applied at the desired frequency and TX attenuation. The receivers are turned off.
- Both the transmitter and receiver are turned off.

Reader synchronization

The reader synchronizes air transmission timing to its own channels and to the redundant CTM, as well as to other readers, if these readers are on the sync network and correctly enabled. To support reader sync at least 1 Sync frame must be configured in the Frame Sequence. For more information see page 146.



ATTENTION: When syncing newer versions of readers with older versions of readers, an advanced knowledge of sync configuration is required. Therefore, it is recommended that Kapsch Service be consulted, as boundaries and limits of variables may not be the default and will need to be reconfigured

Frame Sequence Synchronization rules

When building a multi-protocol tag acquisition sequence (Frame Sequence) where readers are required to be synchronized, the following rules must be followed to avoid errors or warnings.

- Only one sync block may be used when only 1 or 2 protocol sequences are enabled in the multi-protocol sequence.
- If **2 or more** sync blocks are used in the multi-protocol acquisition sequence, one of the blocks must be enabled to **Skip-on-Sync**.
- With multiple sync blocks in an Frame Sequence, they should each be different (e.g. Sync_1, Sync_2) to ensure correct alignment.
- The sequences on the readers must be the same or at least have the same time length(s) between sync block(s). Dummy frames may be used to achieve this if the sequences are different.

Example building a Frame Sequence

Two examples are provided below, one using a single protocol and no sync, while the other is a multi-protocol sequence with sync.

Note 1: To use the examples sequences over the air it is also necessary to set channels to Active or Guard on the Channel page, and to set appropriate attenuations for each channel.

Note 2 : To support read/write operation it is necessary to configure the TDM programming configuration, see Programming tags, page 62.

Connect a service laptop to the reader and via browser connect to the reader web interface.

Example 1: Set up a TDM (Read/Write) protocol, eight (8) lane plaza, not synced to another Reader.

1. Select the **Channels** page. Set the "Number of channels" to 8. This automatically sets a 8 channel TDM scan.



2. Select the **Tag Protocol** page. Select and delete via the  icon, all protocols except TDM. You should have the resulting frame sequence as follows:

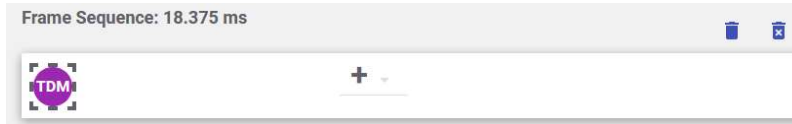

3. Expand the TDM Channel Sequence Firing panel and confirm that each channel 1 to 8 is enabled in a corresponding time slot 1 - 8.

TDM Channel Firing Sequence

No gap is allowed, max 2 time slots per channel and max 2 channels per time slot are allowed.
If TDM only, min 3 time slots shall be enabled or diagonal pattern is set by default.

Ch	Slot1	Slot2	Slot3	Slot4	Slot5	Slot6	Slot7	Slot8
1	<input checked="" type="checkbox"/>	<input type="checkbox"/>	<input type="checkbox"/>	<input type="checkbox"/>	<input type="checkbox"/>	<input type="checkbox"/>	<input type="checkbox"/>	<input type="checkbox"/>
2	<input type="checkbox"/>	<input checked="" type="checkbox"/>	<input type="checkbox"/>	<input type="checkbox"/>	<input type="checkbox"/>	<input type="checkbox"/>	<input type="checkbox"/>	<input type="checkbox"/>
3	<input type="checkbox"/>	<input type="checkbox"/>	<input checked="" type="checkbox"/>	<input type="checkbox"/>	<input type="checkbox"/>	<input type="checkbox"/>	<input type="checkbox"/>	<input type="checkbox"/>
4	<input type="checkbox"/>	<input type="checkbox"/>	<input type="checkbox"/>	<input checked="" type="checkbox"/>	<input type="checkbox"/>	<input type="checkbox"/>	<input type="checkbox"/>	<input type="checkbox"/>
5	<input type="checkbox"/>	<input type="checkbox"/>	<input type="checkbox"/>	<input type="checkbox"/>	<input checked="" type="checkbox"/>	<input type="checkbox"/>	<input type="checkbox"/>	<input type="checkbox"/>
6	<input type="checkbox"/>	<input type="checkbox"/>	<input type="checkbox"/>	<input type="checkbox"/>	<input type="checkbox"/>	<input checked="" type="checkbox"/>	<input type="checkbox"/>	<input type="checkbox"/>
7	<input type="checkbox"/>	<input type="checkbox"/>	<input type="checkbox"/>	<input type="checkbox"/>	<input type="checkbox"/>	<input type="checkbox"/>	<input checked="" type="checkbox"/>	<input type="checkbox"/>
8	<input type="checkbox"/>	<input type="checkbox"/>	<input type="checkbox"/>	<input type="checkbox"/>	<input type="checkbox"/>	<input type="checkbox"/>	<input type="checkbox"/>	<input checked="" type="checkbox"/>

Note: You can use the  icon to reset the TDM channel firing sequence (enable slots 1 to 8 with sequential channels 1 through 8).

Note: New for MPR 2.4, a TDM frame sequence can be as short as 1 time slot.

Example 2: TDM, 6C (6CTOC compliant), and 6B, two (2) Lane ORT with Shoulders (five (5) channels) with five (5) channel scan) and synchronization between readers

Note: Unlike the previous example, for the FDM protocols it is also necessary to set up channel frequencies for each channel, see Frequency Selection, page 61

The detailed steps are as follows.

1. Select the **Channels** page and set "Number of channels" to 5. This sets a 5 channel TDM scan, and enables FDM channels 1 - 5.



2. Select the Tag Protocol page, and assuming TDM is already present, click the + icon and add 6B, click the + icon and add Sync_1, and finally click the + icon and add 6C. The resulting frame sequence should appear as follows:



3. Select the 6B icon from the frame sequence, and expand the 6B Advanced panel., choose the desired options. Enable Dual Tag Preamble.



4. Select the 6C icon from the frame sequence, and expand the 6C Advanced panel, chose the desired options (e.g. 6C Read Mode, Custom Mask Select).

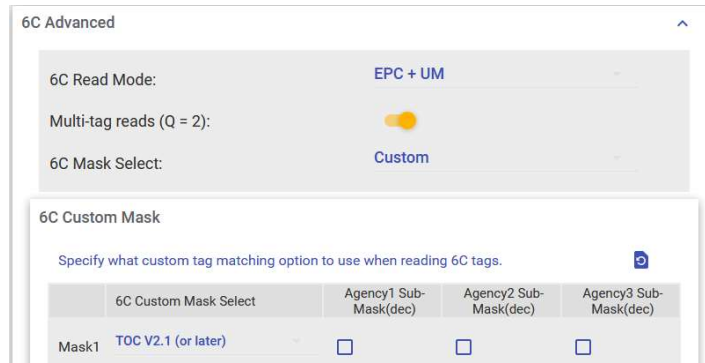

Configuration Alignment



When Configuration Alignment is enabled, the user configures most settings on the Primary side only (exceptions listed below), and the settings are automatically applied to the Secondary side. This reduces set-up time, configuration mis-matches, and avoids having to log in on the Secondary side to manually duplicate settings made on the Primary side.



Configuration Alignment is enabled when the  symbol is displayed in the banner area of the web interface. Configuration Alignment is enabled by default, and can be disabled via a toggle on the Compare page. The following table describes how to change reader settings when Configuration Alignment is enabled.

Table 3-6 Configuration Alignment Operation

Use Case	Secondary CTM Condition	Primary CTM Condition	Configuration Recommendation
Typical dual			Configure common settings on the Primary side only. These settings are automatically applied to the Secondary side.

redundant reader operation.	Running	Running	Configure excluded settings on the Secondary side (see list below). On the Secondary side, any change to a non-excluded parameter gets reverted back to match the Primary side setting.
Primary CTM is off or not present.	Running	OFF	*Non-standard operating mode* Any configuration change made to the Secondary should be applied to the Primary the next time it is running. OR Disable configuration alignment first on the Primary side before turning the Primary off.
Secondary CTM is off or not present.	OFF	Running	As soon as the Secondary is running again, the reader aligns the Secondary side to match the Primary side settings.

Settings excluded from Configuration Alignment

The following settings are excluded from Configuration Alignment, so must be set individually both on the Primary and Secondary. These excluded settings are also listed on the Compare page for reference.

- Reader IP address/netmask
- LC Ethernet Destination IP address/port (also Dual Destination IP address/port)
- Inter-Reader Ethernet 2 IP address
- NTP Peer IPs
- Sync Recovery timeout (normally derived from Frame Sequence setting)
- USB logging
- User Account settings

Configuration Alignment example

The following is an example of how Configuration Alignment operates. The left side is a view of the Secondary side web interface, the right side shows the Primary side web interface. Note that Configuration Alignment happens on the Secondary regardless of whether the user is logged in to the Secondary web interface.

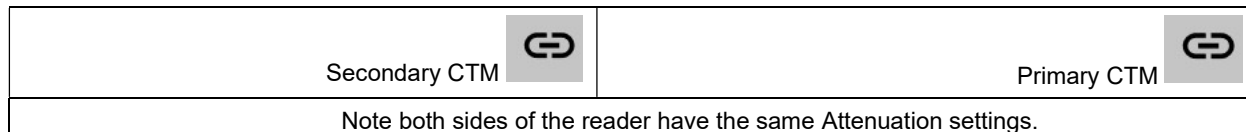

<table border="1"> <thead> <tr> <th>Ch</th> <th>Rx Attenuation (dB)</th> <th>Tx Attenuation (dB)</th> </tr> </thead> <tbody> <tr> <td>1</td> <td>5</td> <td>5</td> </tr> <tr> <td>2</td> <td>5</td> <td>5</td> </tr> <tr> <td>3</td> <td>5</td> <td>5</td> </tr> </tbody> </table>	Ch	Rx Attenuation (dB)	Tx Attenuation (dB)	1	5	5	2	5	5	3	5	5	<table border="1"> <thead> <tr> <th>Ch</th> <th>Rx Attenuation (dB)</th> <th>Tx Attenuation (dB)</th> </tr> </thead> <tbody> <tr> <td>1</td> <td>5</td> <td>5</td> </tr> <tr> <td>2</td> <td>5</td> <td>5</td> </tr> <tr> <td>3</td> <td>5</td> <td>5</td> </tr> </tbody> </table>	Ch	Rx Attenuation (dB)	Tx Attenuation (dB)	1	5	5	2	5	5	3	5	5
Ch	Rx Attenuation (dB)	Tx Attenuation (dB)																							
1	5	5																							
2	5	5																							
3	5	5																							
Ch	Rx Attenuation (dB)	Tx Attenuation (dB)																							
1	5	5																							
2	5	5																							
3	5	5																							
	<p>Now for example, the operator decides to change a power setting on the Primary side. Note how Secondary side is automatically updated to match the Primary. If the Secondary happens to be off, it gets aligned the next time it is running.</p>																								
<table border="1"> <thead> <tr> <th>Ch</th> <th>Rx Attenuation (dB)</th> <th>Tx Attenuation (dB)</th> </tr> </thead> <tbody> <tr> <td>1</td> <td>5</td> <td>4</td> </tr> <tr> <td>2</td> <td>5</td> <td>5</td> </tr> <tr> <td>3</td> <td>5</td> <td>5</td> </tr> </tbody> </table>	Ch	Rx Attenuation (dB)	Tx Attenuation (dB)	1	5	4	2	5	5	3	5	5	<table border="1"> <thead> <tr> <th>Ch</th> <th>Rx Attenuation (dB)</th> <th>Tx Attenuation (dB)</th> </tr> </thead> <tbody> <tr> <td>1</td> <td>5</td> <td>4</td> </tr> <tr> <td>2</td> <td>5</td> <td>5</td> </tr> <tr> <td>3</td> <td>5</td> <td>5</td> </tr> </tbody> </table>	Ch	Rx Attenuation (dB)	Tx Attenuation (dB)	1	5	4	2	5	5	3	5	5
Ch	Rx Attenuation (dB)	Tx Attenuation (dB)																							
1	5	4																							
2	5	5																							
3	5	5																							
Ch	Rx Attenuation (dB)	Tx Attenuation (dB)																							
1	5	4																							
2	5	5																							
3	5	5																							



This Page Intentionally Left Blank

Commands and controls

Table 3-7 lists and describes the commands and controls that can be deployed in the various Configuration screens that are available to a user.

- Note1: In the table, 0 = Disable, 1 = Enable
- Note2: Prmtr Name is the parameter name in the text configuration file that can be saved or loaded to reader, see Saving the Reader configuration, page 215
- Note3 The parameters available in some screens, or the ability to change them, in some cases are dependent on enabling other settings in the same screens first.

Table 3-7: Commands and Controls

Command	How to execute	Who can execute	Prmtr. Name	Default Value	Prmtr. Range	Purpose of command
<p>The banner menu refers to the  icon shown in the top banner. This is present on every page.</p> <p>If you see the  symbol in the banner, you can view but not change reader settings. This is due to an account permission setting.</p>						
Dashboard	<p>In the Main menu: Click Dashboard</p> <p>Shortcut: Click on the top left Kapsch logo in the banner.</p>	Anyone	N/A	N/A	N/A	Return to the reader web interface home page (Dashboard).

Command	How to execute	Who can execute	Prmtr. Name	Default Value	Prmtr. Range	Purpose of command
Set Time	Select Time from the home page, or from the banner menu, or (shortcut) click on the time in the banner menu.	User with Change Configuration permission	N/A	N/A	N/A	Displays the Time page in the web interface. Used to configure NTP, manually set the time, or change the timezone.
Reader Software	Select Reader SW from the home page, or Reader Software from the banner menu.	User with Manage Software permission	N/A	N/A	N/A	Displays the Reader Software page. Used to access upload and verify, activate, and delete software commands, other available software versions, and upload history.
Log Files	Select Logs from the home page, or from the banner menu.	User with Manage Logs permission	N/A	N/A	N/A	Displays the Logs page. Anyone can view logs. Only a user with "Manage logs" permission can delete, download, or copy logs to a USB stick. If these options are greyed out, you do not have "Manage logs" permission.
Log Out	Select Log Out from the banner menu.	anyone	N/A	N/A	N/A	Immediately logs the current user out of the CTM web interface.
Dashboard Page						
Configuration	On Dashboard page.	anyone	N/A	N/A	N/A	Displays the Configure panel. Used to access a variety of Reader configuration parameters.

Command	How to execute	Who can execute	Prmtr. Name	Default Value	Prmtr. Range	Purpose of command
Manage Reader Software	In Manage panel, click Reader SW button.	anyone	N/A	N/A	N/A	Displays the Reader Software page to view the current running software. Used to load new reader software and delete old versions.
View Log Files	In Manage panel, click Logs button.	anyone	N/A	N/A	N/A	Displays the Logs page to view reader log files. Any user can view log files.
View Status	In Manage panel, click Status button.	anyone	N/A	N/A	N/A	Displays the reader Status page. Used to monitor reader status.
Restart	In Manage panel, click the Restart SW link.	anyone	N/A	N/A	N/A	Restart the Reader application.
Shutdown	In Manage panel, click the Shutdown link.	anyone	N/A	N/A	N/A	Shutdown the Reader for maintenance. Need to manually power cycle the Reader to start again.
Manage Panel From Dashboard page						
Status	From the Manage panel of the Dashboard page: Click Status button.	anyone	N/A	N/A	N/A	Displays the Status page. Used to monitor communication, power supply, reader status, RF modules and transaction buffering.
Manage Users	From the Manage panel of the Dashboard page: Click Users button.	anyone	N/A	N/A	N/A	Displays the Users page. Used to access user profiles, create new users, delete users, change permissions, change passwords.

Command	How to execute	Who can execute	Prmtr. Name	Default Value	Prmtr. Range	Purpose of command
System Identification	From the home page, click Identify in the Manage panel.	anyone	N/A	N/A	N/A	Causes the CTM MC LED to flash green-red-amber-green three times Used to confirm which reader is being accessed.
Reboot	From the home page, click Reboot in the Manage panel.	anyone	N/A	N/A	N/A	Reboots the Reader. If done on the Primary side of a redundant reader the reader will switchover automatically to the Secodnary side.
General page						
Site Name	On the Site Information panel of the General page: Type a Reader name in Site Name text.	User with Change Configuration permission	SITENM	no default value	String length: 32	Sets the site name shown in the web interface banner, reported in reader log files and when saving the reader configuration.  The reader will automatically add a "-pri" suffix for the Primary side CTM, and a "-sec" suffix for the Secondary side.

Command	How to execute	Who can execute	Prmtr. Name	Default Value	Prmtr. Range	Purpose of command
Site Type	From the Site Information panel of the General page: Select a Site Type.	User with Change Configuration permission	SITETY	PLAZA	PLAZA ORT (with straddle antennas) ORT (no straddle antennas) ORT staged Lab/table top demo	Sets the site type used only for descriptive purposes.
Reader IP Address	On the Network panel of the General page: Type an IP address in Reader IP Address field.	User with Change Configuration permission	LETHIF	192.168.1.50	N/A	Set the IPv4 address of the ETHERNET 1 interface
Reader IP Subnet mask	On the Network panel of the General page: Type the subnet mask address in the Reader IP Subnet Mask field	User with Change Configuration permission	LETHNM	255.255.255.0	N/A	Set the ETHERNET 1 interface Subnet mask according to your LAN requirements.
Default Gateway IP	On the Network panel of the General page: Type an IP address in the Default Gateway IP Address field	User with Change Configuration permission	DFGWIP	0.0.0.0	N/A	Set a gateway IPv4 address if needed by your LAN requirements. Set to 0.0.0.0 if not using a gateway.

Command	How to execute	Who can execute	Prmtr. Name	Default Value	Prmtr. Range	Purpose of command
SNMP Trap Enable	On the SNMP panel of the General page: Select SNMP Traps switch	User with Change Configuration permission	CSTRAP	0	0 - 1	Used to enable and disable SNMP traps
SNMP Trap Destination #1	On the SNMP panel of the General page: Type an IP address and port in the TRAPIP 1 address field	User with Change Configuration permission	TRAPIP	Ip 0.0.0.0 and port 162	N/A	Used to define IP address and port of Trap destination #1
SNMP Trap Destination #2	On the SNMP panel of the General page: Type an IP address and port in the TRAPIP 2 address field	User with Change Configuration permission	TRAP_2	Ip 0.0.0.0 and port 162	N/A	Used to define IP address and port of Trap destination #2
SNMP Trap Destination #3	On the SNMP panel of the General page: Type an IP address and port in the TRAPIP 3 address field	User with Change Configuration permission	TRAP_3	Ip 0.0.0.0 and port 162	N/A	Used to define IP address and port of Trap destination #3

Command	How to execute	Who can execute	Prmtr. Name	Default Value	Prmtr. Range	Purpose of command
Switchover on Serial Link Down	On the Switchover panel of the General page: Select the Switchover on serial LC link down switch.	User with Change Configuration permission	SOSERL	0	0-1	Disabled: switchover does not occur when a serial LC link is down. Enabled: Enable means switch-over when a serial LC link is down. Has no meaning on secondary side. Note: If enabled, you MUST also disable all unused COM ports (see SERIAL tab) as well as unused LC destinations (see LC tab).
Switchover on Ethernet LC Link Down	On the Switchover panel of the General page: Select the Switchover on Ethernet LC link down switch.	User with Change Configuration permission	SO_ETH	0	0-1	Disabled: switchover does not occur when a Ethernet LC link is down. Enabled: switchover when an Ethernet link to the LC is down.
Switchover on Ethernet IRIF Link Down	On the Switchover panel of the General page: Select the Switchover on Inter-Reader link down switch.	User with Change Configuration permission	SOIRIF	0	0-1	Disabled: switchover does not occur when the Ethernet IRIF link is down. Enabled: Enable means switch-over if a connection to an adjacent reader over the Ethernet interface is down.
Statistics Retention period	On the Reader Statistics panel of the General page: Enter a number in the Statistics Retention period field.	User with Change Configuration permission	SDSRET	30	7 - 90	Use to specify how many days transaction summary data is retained.

Command	How to execute	Who can execute	Prmtr. Name	Default Value	Prmtr. Range	Purpose of command
Statistics Summary Interval	On the Reader Statistics panel of the General page: Enter a value in the Statistics Summary Interval field	User with Change Configuration permission	SDSINT	15	1 - 30	Generates transaction summary records into database at specified time interval. Values below 5 minutes for testing only. May be automatically adjusted by reader based on load and retention period
Tag Protocol Page						
Suppress Non-IAG Tags	On the TDM Advanced panel of the Tag Protocol page: Select Suppress Non-IAG Tags	User with Change Configuration permission	NONIAG	1	0 - 1	Disabled: All TDM transactions are reported Enabled: Suppresses reporting of TDM OBUs not matching the IAG Group ID with which the Reader is provisioned Used to prevent incompatible report formats from being sent to the LC
RxR Autoread	On the TDM Advanced panel of the Tag Protocol page: Select RxR switch.	User with Change Configuration permission	RxRARD	0	0-1	Specifies the TDM transactions as either RPV or RxR format.

Command	How to execute	Who can execute	Prmtr. Name	Default Value	Prmtr. Range	Purpose of command
Lane Number	On the TDM Tag Programming panel on the Tag Protocol page, with TDM Tag Programming enabled, enter a value from 0 to 31 in each channel number field.	User with Change Configuration permission	RFLNUM	Per-instance defaults. Instance:0 value:1 instance:1 value:2 instance:7 value:8	0-31	A value from 0 to 31 written to a TDM OBU as it goes through the capture zone. NOTE: In an ORT environment, the channel writing to the OBU may not be the same as the one assigned to the Vote report.
Plaza ID	On the TDM Tag Programming panel on the Tag Protocol page, with TDM Tag Programming enabled, enter a numeric Plaza ID.	User with Change Configuration permission	PID__	0	0-127	Sets Plaza ID Written to TDM OBU memory.
Agency ID	On the TDM Tag Programming panel on the Tag Protocol page, with TDM Tag Programming enabled, enter a numeric Agency ID.	User with Change Configuration permission	AID__	0	0 - 127	Sets the agency ID Witten to TDM OBU memory.
6C Read-Only Mode	On the 6C Programming panel on the Tag Protocol page, check Enable switch.	User with Change Configuration permission	6CROLY	1	0-1	Controls whether the reader writes or does not write to 6C tags.

Command	How to execute	Who can execute	Prmtr. Name	Default Value	Prmtr. Range	Purpose of command
6C Try-To-Program Timeout [sec]	On the 6C Programming panel on the Tag Protocol page, with Enable switch ON: Enter time quantity in seconds in the 6C Try-To-Program Timeout [sec] field	User with Change Configuration permission	6C_TTP	500	0-4294967295	Specifies, in seconds, the duration after which additional programming attempts will be made with an existing 6C tag.
6C Agency ID (Decimal)	On the 6C Programming panel on the Tag Protocol page, with Enable switch ON. Enter a numeric Agency ID.	User with Change Configuration permission	6C_AID	0	0 - 4095	Sets the agency ID To keep a record in OBUs of the agency ID
6C Read Mode:	On the 6C Programming panel on the Tag Protocol page Select 6C Read Mode from the drop-down list.	User with Change Configuration permission	6C_RDM	EPC only (0)	EPC only (0) EPC+TID (1) EPC + UM (2)	Specifies what mode to use when reading 6C tags.
Multi-tag reads (Q = 2)	On the 6C Programming panel on the Tag Protocol page Set toggle switch to ON to enable.	User with Change Configuration permission	6C_MT	0	0 - 1	Enable to allow multiple 6C tags to be read per frame, at the expense of a longer frame time. When disabled, only one 6C tag may be read per frame. When enabled, the 6C Q-value = 2; when disabled the Q-value is 0.

Command	How to execute	Who can execute	Prmtr. Name	Default Value	Prmtr. Range	Purpose of command
6C Mask Select	On the 6C Programming panel on the Tag Protocol page Select 6C mask from the drop-down list.	User with Change Configuration permission	6C_MSK	Standard (0)	Standard (0) Puerto Rico (1) Custom (2)	Specify what 6C Read Masking to use when reading 6C tags.
6C Custom Mask Select	On the 6C Programming panel on the Tag Protocol page Select 6C custom mask from the drop-down list.	User with Change Configuration permission	6CCMSK	None (0)	None (0) TOC V2.1 (or later) (1) TOC V2.0 (WSDOT) (2) Legacy WSDOT (3) TOC V0.7-V1.0 (E470) (4) TOC V0.7-V1.0 (TI Corp.) (5) Legacy SRTA (6)	Specify what custom tag matching option to use when reading 6C tags.

Command	How to execute	Who can execute	Prmtr. Name	Default Value	Prmtr. Range	Purpose of command
6C Sub-Mask Enable	On the 6C Programming panel on the Tag Protocol page When TOC V2.1 or TOC V2.0 are selected, checkbox will be shown in Agency Sub-Mask. Select checkbox to enable.	User with Change Configuration permission	6C_SME	Off (0)	Off (0) – Agency 1 (0x00000001) Agency 2 (0x00000002) Agency 3 (0x00000004)	Specify whether or not a Sub Mask is to be enabled for the selected 6C Custom Mask.
Agency 1 Sub-Mask (dec)	On the 6C Programming panel on the Tag Protocol page With 6C Sub-Mask enabled, enter 6C Agency ID Sub-Mask.	User with Change Configuration permission	6CSMA1	0	0-4294967295	Specify the 6C Agency ID Sub-Mask to use. Please specify a (maximum of 32-bits) value in decimal. An Agency ID Mask value of 0 represents no mask in effect. Note: The maximum allowed value is determined by the selected mask.
Agency 2 Sub-Mask (dec)	On the 6C Programming panel on the Tag Protocol page With 6C Sub-Mask enabled, enter 6C Agency ID Sub-Mask.	User with Change Configuration permission	6CSMA2	0	0-4294967295	Specify the 6C Agency ID Sub-Mask to use.
Agency 3 Sub-Mask (dec)	With 6C Sub-Mask enabled, enter 6C Agency ID Sub-Mask.	User with Change Configuration permission	6CSMA3	0	0-4294967295	Specify the 6C Agency ID Sub-Mask to use.

Command	How to execute	Who can execute	Pmtr. Name	Default Value	Pmtr. Range	Purpose of command
TDM Read-Only Mode	On the TDM Tag Programming panel on the Tag Protocol page, check Enable switch	User with Change Configuration permission	RONLY	0	0-1	Controls whether the reader writes or does not write to TDM tags.
Enable TMP	On the Traffic Management Programming (TMP) panel on the Tag Protocol page, check Enable switch	User with Change Configuration permission	TMP___	1	0-1	Enable means write a timestamp and Reader ID in transponder memory. Disabled means the reader does not update those fields.
Reader ID	On the Traffic Management Programming (TMP) panel on the Tag Protocol page: Enable or disable the Reader ID switch.	User with Change Configuration permission	rw_RID	1	0-1	Determines whether or not to program the TM-DATA reader ID field of the tag's R/W area

Command	How to execute	Who can execute	Prmtr. Name	Default Value	Prmtr. Range	Purpose of command
Reader ID	On the TDM Tag Programming panel on the Tag Protocol page: Enter a value in the Reader ID field. Note: Make sure a unique Reader ID is used when there are multiple readers at a plaza.	User with Change Configuration permission	RID___	0	min: 0 max: 4095	Use to enter a value which is written into the transponder if either Traffic Management or Cross Reader Algorithm (Classic) is enabled.
TM Date/Time	On the Traffic Management Programming (TMP) panel on the Tag Protocol page: Either enable or disable the TMP switch.	User with Change Configuration permission	rwTMDT	1	0-1	Determines whether or not to program the TM-DATA date/time fields of the tag's R/W area Disabled: the Reader date and time is not written to OBUs Enabled: the Reader date and time is written to OBUs to keep a record in OBUs of the TM transaction time
Enable TCP	On the Toll Collection Programming (TCP) panel on the Tag Protocol page: Select the Enable TCP switch ON position.	User with Change Configuration permission	TCP___	1	0-1	Disabled: Reader is not permitted to update toll collection fields in OBUs. Enabled: Reader is permitted to update toll collection fields in OBUs. To control if toll collection fields can be written to OBUs and to access TCP settings in the Tag Programming tab.

Command	How to execute	Who can execute	Prmtr. Name	Default Value	Prmtr. Range	Purpose of command
R/W Enable Plaza ID	On the Toll Collection Programming (TCP) panel on the Tag Protocol page: With TCP enabled, select the Plaza ID switch.	User with Change Configuration permission	rw_PZID	N/A	N/A	Enables Plaza ID to be written to OBUs. To write Plaza ID to OBUs and access the Plaza ID field.
Agency ID (enable)	On the Toll Collection Programming (TCP) panel on the Tag Protocol page: With TCP enabled, select the Agency ID switch.	User with Change Configuration permission	rw_AID	1	0-1	Enables Agency ID to be written to OBUs. To write the agency ID to OBUs and access the Agency ID field.
Transaction number programming (enable)	On the Toll Collection Programming (TCP) panel on the Tag Protocol page: With TCP enabled, select the Transaction number programming switch.	User with Change Configuration permission	rw_TXN	1	0-1	Enables a Transaction number to be written to the OBU. To write a transaction number to OBUs and to access the transaction number programming options.

Command	How to execute	Who can execute	Prmtr. Name	Default Value	Prmtr. Range	Purpose of command
Transaction number programming	On the Toll Collection Programming (TCP) panel on the Tag Protocol page: With Transaction number programming enabled, select the appropriate calculation type from the Transaction number programming box.	User with Change Configuration permission	TFRM__	Reprogram with 16 bit sequential transaction number.	Don't reprogram transaction field. Reprogram with 16 bit random number. Reprogram with 16 bit sequential transaction number. Reprogram with 8 bit random number and 8 bit sequential number.	Sets the way the Reader creates an OBU transaction number. To choose how the Reader determines OBU transaction numbers.
OBU Feedback	On the Toll Collection Programming (TCP) panel on the Tag Protocol page: Select the OBU Feedback switch.	User with Change Configuration permission	rw_OBU	0	0-1	Disabled: programs feedback-type OBUs to not provide feedback. Enabled: programs feedback-type OBUs to provide feedback. To configure feedback-type OBUs to notify when an ETC transaction has occurred.

Command	How to execute	Who can execute	Pmtr. Name	Default Value	Pmtr. Range	Purpose of command
TC Date/Time	On the Toll Collection Programming (TCP) panel on the Tag Protocol page: With TCP enabled, select TC Date/Time switch	User with Change Configuration permission	TCDTTM	0	0-1	Disabled: Reader Date/Time not written to OBU TC data fields. Enabled: Reader Date/Time written to OBU TC data fields. To keep a record in OBUs of the TC transaction time.
RW Format	On the Toll Collection Programming (TCP) panel on the Tag Protocol page: With TCP enabled, select the TC RW Format switch.	User with Change Configuration permission	rw__RW	0	0-1	Disabled: RW Format not affected. Enabled: Reader controls how OBU scratchpad memory is encoded. Determines how the data stored in OBU scratchpad memory is encoded.
Lane Number (enable)	On the Toll Collection Programming (TCP) panel on the Tag Protocol page: With TCP enabled, select the TC Lane Number switch.	User with Change Configuration permission	rwLANE	1	0-1	Enables lane number programming. To enable ability to set a specific lane number for each RF channel.

Command	How to execute	Who can execute	Prmtr. Name	Default Value	Prmtr. Range	Purpose of command
HOT (High Occupancy Toll) lane	On the Toll Collection Programming (TCP) panel on the Tag Protocol page: With TCP enabled, select the HOT (High Occupancy Toll) Lane switch ON, then, select the desired lane check box.	User with Change Configuration permission	HOT_LN	0	0 - 1	Enable HOT lane programming in a specific lane. 0 = disabled 1 = enabled
OBU Feedback type	On the Toll Collection Programming (TCP) panel on the Tag Protocol page: With OBU feedback enabled, select Type 1 or Type 2.	User with Change Configuration permission	OBUTYP	Type 1	0 (Type 1) 1 (Type 2)	Specifies which type of OBU feedback to employ: TYPE1: all feedback tags provide the same feedback. TYPE2: feedback is unique according to a Status File previously downloaded to reader

Command	How to execute	Who can execute	Prmtr. Name	Default Value	Prmtr. Range	Purpose of command
OBU Audible Feedback	On the Toll Collection Programming (TCP) panel on the Tag Protocol page: With OBU Feedback enabled and Type 1 selected, select a feedback option from the OBU Audible Feedback drop-down box.	User with Change Configuration permission	OBUAUD	Off	Off 4 cycles: 0.25s ON, 0.25s OFF 1 cycle: 1.5s ON 3 cycles: 0.5s ON, 0.2s OFF	Specifies the type of audible feedback an OBU provides. To configure how long and how many times an OBU beeps to indicate a successful transaction.
OBU Visual Feedback	On the Toll Collection Programming (TCP) panel on the Tag Protocol page: With OBU feedback enabled and Type 1 selected, select a feedback option from the OBU Visual Feedback drop-down box.	User with Change Configuration permission	OBUVIS	Off	Off Green: 2s Red: 2s Yellow: 2s	Turns on and specifies the type of visual feedback an OBU provides. To configure how long and what color an OBU LED flashes to indicate a successful transaction.

Command	How to execute	Who can execute	Prmtr. Name	Default Value	Prmtr. Range	Purpose of command
Valid Tag: Audible	On the Toll Collection Programming (TCP) panel on the Tag Protocol page: With OBU Feedback enabled, and Type 2 selected, select a feedback option from the OBU Audible Feedback drop-down box.	User with Change Configuration permission	O2VLDA	Off	Off 4 cycles: 0.25s ON, 0.25s OFF 1 cycle: 1.5s ON 3 cycles: 0.5s ON, 0.2s OFF	Specifies the audible feedback to provide for a valid tag. To configure how long and how many times an OBU beeps to indicate a successful transaction. OBU feedback type 2 parameters only apply to TDM tags if a status file has been transferred to the Reader.
Valid Tag: Visual	On the Toll Collection Programming (TCP) panel on the Tag Protocol page: With OBU feedback enabled, and Type 2 selected, select a feedback option from the OBU Visual Feedback drop-down box.	User with Change Configuration permission	O2VLDV	Off	Off Green: 2s Red: 2s Yellow: 2s	Specifies the visual feedback to provide in the case of a valid tag. To configure how long and what color an OBU LED flashes to indicate a successful transaction. OBU feedback type 2 parameters only apply to TDM tags if a status file has been transferred to the Reader.

Command	How to execute	Who can execute	Prmtr. Name	Default Value	Prmtr. Range	Purpose of command
Invalid Tag: Audible	On the Toll Collection Programming (TCP) panel on the Tag Protocol page: With OBU feedback enabled, and Type 2 selected, select a feedback option from the OBU Audible Feedback drop-down box.	User with Change Configuration permission	O2IVDA	Off	Off 4 cycles: 0.25s ON, 0.25s OFF 1 cycle: 1.5s ON 3 cycles: 0.5s ON, 0.2s OFF	Specifies the audible feedback to provide for an invalid tag. To configure how long and how many times an OBU beeps to indicate a successful transaction. OBU feedback type 2 parameters only apply to TDM tags if a status file has been transferred to the Reader.
Invalid Tag: Visual	On the Toll Collection Programming (TCP) panel on the Tag Protocol page: With OBU feedback enabled, and Type 2 selected, select a feedback option from the OBU Visual Feedback drop-down box.	User with Change Configuration permission	O2IVDV	Off	Off Green: 2s Red: 2s Yellow: 2s	Specifies the visual feedback to provide in the case of an invalid tag. To configure how long and what color an OBU LED flashes to indicate a successful transaction. OBU feedback type 2 parameters only apply to TDM tags if a status file has been transferred to the Reader.

Command	How to execute	Who can execute	Prmtr. Name	Default Value	Prmtr. Range	Purpose of command
Lost/Stolen Tag: Audible	On the Toll Collection Programming (TCP) panel on the Tag Protocol page: With OBU feedback enabled, and Type 2 selected, select a feedback option from the OBU Audible Feedback drop-down box.	User with Change Configuration permission	O2LSTA	Off	Off 4 cycles: 0.25s ON, 0.25s OFF 1 cycle: 1.5s ON 3 cycles: 0.5s ON, 0.2s OFF	Specifies the audible feedback to provide for a lost/stolen tag. To configure how long and how many times an OBU beeps to indicate a successful transaction. OBU feedback type 2 parameters only apply to TDM tags if a status file has been transferred to the Reader.
Lost/Stolen Tag: Visual	On the Toll Collection Programming (TCP) panel on the Tag Protocol page: With OBU feedback enabled, and Type 2 selected, select a feedback option from the OBU Visual Feedback drop-down box.	User with Change Configuration permission	O2LSTV	Off	Off 1 (Green: 2s) 2 (Red: 2s) 3 (Yellow: 2s)	Specifies the visual feedback to provide in the case of a lost/stolen tag. To configure how long and what color an OBU LED flashes to indicate a successful transaction. OBU feedback type 2 parameters only apply to TDM tags if a status file has been transferred to the Reader.

Command	How to execute	Who can execute	Prmtr. Name	Default Value	Prmtr. Range	Purpose of command
Low Balance Tag: Audible	On the Toll Collection Programming (TCP) panel on the Tag Protocol page: With OBU feedback enabled, and Type 2 selected, select a feedback option from the OBU Audible Feedback drop-down box.	User with Change Configuration permission	O2LBLA	Off	Off 1 (4 cycles: 0.25s ON, 0.25s OFF) 2 (1 cycle: 1.5s ON) 3 (3 cycles: 0.5s ON, 0.2s OFF)	Specifies the audible feedback to provide for a low balance tag. To configure how long and how many times an OBU beeps to indicate a low balance tag.
Low Balance Tag: Visual	On the Toll Collection Programming (TCP) panel on the Tag Protocol page: With OBU feedback enabled, and Type 2 selected, select a feedback option from the OBU Visual Feedback drop-down box.	User with Change Configuration permission	O2LBLV	Off	Off Green: 2s Red: 2s Yellow: 2s	Specifies the visual feedback to provide in the case of a low balance tag. To configure how long and what color an OBU LED flashes to indicate a low balance tag.

Command	How to execute	Who can execute	Prmtr. Name	Default Value	Prmtr. Range	Purpose of command
Not Available / Internal Error: Audible	On the Toll Collection Programming (TCP) panel on the Tag Protocol page: With OBU feedback enabled, and Type 2 selected, select a feedback option from the OBU Audible Feedback drop-down box.	User with Change Configuration permission	O2NA_A	Off	Off 4 cycles: 0.25s ON, 0.25s OFF 1 cycle: 1.5s ON 3 cycles: 0.5s ON, 0.2s OFF	Specifies the audible feedback to provide for a not available / internal error.
Not Available / Internal Error: Visual	On the Toll Collection Programming (TCP) panel on the Tag Protocol page: With OBU feedback enabled, and Type 2 selected, select a feedback option from the OBU Visual Feedback drop-down box.	User with Change Configuration permission	O2NA_V	Off)	Off) Green: 2s Red: 2s Yellow: 2s	Specify the visual feedback to provide in the case of a not available / internal error

TDM Rx Attenuation [dB]	From the corresponding protocol Configuration panel of the Tag Protocol page: Select the appropriate fields and enter attenuation	User with Change Configuration permission	TA6RX1	0	0 - 31	Provides the default base-line protocol Rx/Tx Attenuation settings
TDM Tx Attenuation [dB]			TA6TX1			
Title21 Rx Attenuation [dB]			TA6RX3			
Title21 Tx Attenuation [dB]			TA6TX3			
SeGo Rx Attenuation [dB]			FA6RX1			
SeGo Tx Attenuation [dB]			FA6TX1			
6B Rx Attenuation [dB]			FA6RX2			
6B Tx Attenuation [dB]			FA6TX2			
6C Rx Attenuation [dB]			FA6RX3			
6C Tx Attenuation [dB]			FA6TX3			
ATA Rx Attenuation [dB]			FA6RX4			
ATA Tx Attenuation [dB]			FA6TX4			
Dummy (CW) Tx Attenuation [dB]			DA6TX1			

Command	How to execute	Who can execute	Prmtr. Name	Default Value	Prmtr. Range	Purpose of command
TDM Frequency [MHz] Title21 Frequency [MHz] SeGo Frequency [MHz] 6B Frequency [MHz] 6C Frequency [MHz] ATA Frequency [MHz] Dummy (CW) Frequency [MHz]	From the corresponding protocol Configuration panel of the Tag Protocol page, specify the frequency.	User with Change Configuration permission	IAGFRQ T21FRQ SGOFRQ I6BFRQ I6CFRQ ATAFRQ DUMFRQ	915.75 (15) 915.75 (15) 902.50 (0) 902.50 (0) 902.50 (0) 902.50 (0) 902.50 (0)	902.5 to 903.5 MHz and 910 to 921.5 MHz Dependent on specific protocol See Appendix B	Specifies the protocol frequencies
Frame Sequence	On the Frame Sequence box of the Tag Protocol page:	User with Change Configuration permission	N/A	Empty	Empty TDM SeGo 6B 6C ATA Dummy_1 Sync_1	Specifies the Frame Sequence Slot protocol/function. Used to specify the protocol firing and/or the Synchronization Sequence of the Reader.

Command	How to execute	Who can execute	Prmtr. Name	Default Value	Prmtr. Range	Purpose of command
Time Slot enable	<p>On the Tag Protocol page:</p> <p>When a FDM protocol (6B, 6C, SeGo, ATA) is selected from the Frame Sequence, set toggle switch to ON in Time Slot table column to enable firing for each channel.</p> <p>For TDM /Title 21 protocol, see the Channel Firing Sequence panel in below.</p>	User with Change Configuration permissions	6C_TSC SGOTSC 6B_TSC ATATSC	0	0-1	For FDM protocol, specify the tag protocol channel/slot firing sequence.
TDM Timeslot Config.	<p>From the TDM Channel Firing Sequence panel of the Tag Protocol page:</p> <p>Select the required Channel # and slot.</p>	User with Change Configuration permission	IAGTSC	0	00-FF (hex) where each bit represents one time slot	Specifies the channel/slot firing sequence for the TDM frame sequence timeslot.

Command	How to execute	Who can execute	Prmtr. Name	Default Value	Prmtr. Range	Purpose of command
Title21 Timeslot Config.	From the Title21 Channel Firing Sequence panel of the Tag Protocol page: Select the required Channel # and slot.	User with Change Configuration permission	T21TSC	0	00-FF (hex) where each bit represents one time slot	Specifies the channel/slot firing sequence for the Title21 frame sequence timeslot.
SeGo Timeslot Config	From the SeGo Channel Firing Sequence panel of the Tag Protocol page Enable the required Channel #	User with Change Configuration permission	N/A	0	0 – 1 (for Ch# 1 - 8)	Specifies the channel/slot firing sequence for the SeGo frame sequence timeslot.
6B Read Mode:	From the 6B Advanced panel of the Tag Protocol page: Select read mode from the drop-down list.	User with Change Configuration permission	6B_RDM	Standard (UDI only) (0)	Standard (UDI only) (0) eATA read – Single-page mode (UDI+eATA) (1) eATA read – 3-page mode (UDI+eATA) (2)	Specifies what mode to use when reading 6B tags. Standard Mode: reads the UID of the tag only. Single-Page eATA Read Mode: reads both the UID and the eATA data in the tag, one page at a time, per superframe, and is a legacy mode that should be used when SYNCing to legacy MPR2 readers. 3-Page eATA Read Mode: is the preferred option to attempt to read all 3 pages (UDI+eATA) in a single superframe scan.

Command	How to execute	Who can execute	Prmtr. Name	Default Value	Prmtr. Range	Purpose of command
eATA Page Read Retry Limit	From the 6B Advanced panel of the Tag Protocol page: Input a numeric value for retry limit.	User with Change Configuration permission	6B3PRR	3	0-10	When 6B is enabled and eATA data is being requested, one page at a time, this value determines, in the event of an eATA page read error, the maximum number of consecutive retries that will be attempted when trying to read a given eATA page.
6B Data Rate (kbps)	From the 6B Advanced panel of the Tag Protocol page: Select data rate from the drop-down list.	User with Change Configuration permission	6BRATE	40 (1)	31.25 (0) 40 (1)	Specify the 6B Data Rate
Enable 6B GROUP_SELECT	From the 6B Advanced panel of the Tag Protocol page: Set toggle switch to ON to enable	User with Change Configuration permission	6BMSKE	0	0-1	Enable this parameter to allow the reader to instruct the Reader to activate the 6B GROUP_SELECT function. This allows the Reader to select a subset of tags from a given tag population.
6B GROUP_SELECT Address (base 10)	From the 6B Advanced panel of the Tag Protocol page: With 6B GROUP_SELECT enabled, input select address.	User with Change Configuration permission	6BADDR	0	0-FF	Specify the 6B GROUP_SELECT address to use (in base 10, not hex).

Command	How to execute	Who can execute	Prmtr. Name	Default Value	Prmtr. Range	Purpose of command
6B GROUP_SELECT Mask (base 10)	From the 6B Advanced panel of the Tag Protocol page: With 6B GROUP_SELECT enabled, input mask.	User with Change Configuration permission	6BMASK	0	0-FF	Specify the 6B GROUP_SELECT mask to use (in base 10, not hex).
6B GROUP_SELECT Data (Hex)	From the 6B Advanced panel of the Tag Protocol page: With 6B GROUP_SELECT enabled, input data.	User with Change Configuration permission	6BDATA	0000000000000000	0000000000000000 0 - FFFFFFFFFFFFFFFF	Specify the 6B GROUP_SELECT Data to use. Please enter a 16-digit (64-bit) hexadecimal value.
Initial CW Time (µs)	From the 6B Advanced panel of the Tag Protocol page: Select cw time from the drop-down list.	User with Change Configuration permissions	6BICWT	400 (4)	Off (0) 100 (1) - 1500 (15) (in 100 µs steps)	Specifies the initial CW time (in µs)
Dual Tag Preamble	From the 6B Advanced panel of the Tag Protocol page: Set toggle switch to ON to enable	User with Change Configuration permission	6B_DTP	0	0 - 1	Specifies whether or not the Dual Tag Preamble is transmitted during the 6B frame.
Preamble Type	From the 6B Advanced panel of the Tag Protocol page:	User with Change Configuration permission	6B_PRT	Plaza (0)	Plaza (0) ORT (1)	Specify the 6B preamble type.

Command	How to execute	Who can execute	Prmtr. Name	Default Value	Prmtr. Range	Purpose of command
	Select preamble type from the drop-down list.					
Agency ID	From the Title21 Advanced panel of the Tag Protocol page: Enter a numeric agency id.	User with Change Configuration permission	T21AID	0	0- 65535	Specify the desired Title21 Agency ID, in decimal.
Reader ID	From the Title21 Advanced panel of the Tag Protocol page: Enter a numeric reader id.	User with Change Configuration permission	T21RID	0	0-4294967295	Specify the desired Title21 Reader ID, in decimal.
Enable Title21 Acknowledge Messages	From the Title21 Advanced panel of the Tag Protocol page: Set toggle switch to ON to enable.	User with Change Configuration permissions	T21AME	0	0-1	Select whether or not to enable the transmission of Title21 Acknowledge Messages to the transponder at the end of the transaction.
Dummy Timeslot (CW) Enable	From the Dummy Timeslot Enable panel of the Tag Protocol page: With Dummy_1/2/3/4 protocol selected,	User with Change Configuration permission	DUMTS1 DUMTS2 DUMTS3 DUMTS4	0	per channel instance: 0-1	Specify the channel/slot firing sequence for the Dummy_x (CW) frame sequence timeslot where 'x' is 1/2/3/4.

Command	How to execute	Who can execute	Prmtr. Name	Default Value	Prmtr. Range	Purpose of command
	for each channel, select Dummy checkbox to enable CW.					
Dummy Frame Length	From the Dummy Advanced panel of the Tag Protocol page: Enter frame length in the field.	User with Change Configuration permission	DUMTSD	500	per dummy instance (up to 4 instances): 500 - 32767	Specifies the duration of the Dummy (CW) timeslot. Note: When combined with the Dummy Frame Length Units parameter, below, the (min, max) allowable Dummy Frame Length when CW is enabled is (500 μ s, 200 ms)
Dummy Frame Length Units	From the Dummy Advanced panel of the Tag Protocol page: Select the required multiple from drop-down list.	User with Change Configuration permission	DUMTSU	x1 μ s (0)	per dummy instance (up to 4 instances): x1 μ s (0) x 100 μ s (1)	Specifies the units to be used when specifying the duration of the Dummy timeslot. Note: When combined with the Dummy Frame Length Units parameter, above, the (min, max) allowable Dummy Frame Length when CW is enabled is (500 μ s, 200 ms)
Reader-to-Reader Sync. Enable	From the Sync Advanced panel of the Tag Protocol page: When Sync is selected in frame sequence, Reader-to-Reader sync will be enabled automatically. If Sync is deselected, Reader-to-Reader sync will be disabled automatically.	User with Change Configuration permission	RFSYNC	0	0 - 1	Controls whether RF transmission is synchronized between adjacent readers. Note: A sync cable to connect readers is required if Reader-to-Reader sync is to be enabled.

Command	How to execute	Who can execute	Prmtr. Name	Default Value	Prmtr. Range	Purpose of command
Sync. Recovery Attempt Limit	From the Sync Advanced panel of the Tag Protocol page: Enter attempt limit in field.	User with Change Configuration permission	SYNRTL	0	0 – 100	This value specifies how many Sync Recovery Time Periods must expire before the reader will no longer search/wait for sync before firing its tag acquisition sequences independently of the reader sync network. If set to zero, the Reader will always wait for the Sync Recovery Time to expire before firing its tag acquisition sequence.
Enable Custom Sync Timing	From the Sync Advanced panel of the Tag Protocol page: Set toggle switch to ON to enable.	User with Change Configuration permission	SYNCSE	0	0-1	Enables/disable custom sync timing.
Sync Search Time (μs)	From the Sync Advanced panel of the Tag Protocol page: With Custom Sync Timing enabled, enter sync search time in us.	User with Change Configuration permission	SYNSTO	100 μs	20 - 65535 μs	Specify how long the Sync function will search for the synchronization signal in microseconds (μs) before switching to recovery mode.
Sync Recovery Time (ms)	From the Sync Advanced panel of the Tag Protocol page: With Custom Sync Timing enabled,	User with Change Configuration permission	SYNRTO	20 ms	0 - 65535 ms	Specify how long the Sync function will attempt synchronization recovery in the event that the sync signal is not seen during the Sync Search phase. Note: It is recommended that this value be set to at least 125% of the total multi-protocol tag acquisition sequence.

Command	How to execute	Who can execute	Prmtr. Name	Default Value	Prmtr. Range	Purpose of command
	enter sync recovery time in ms.					
Sync Frame Start Delay (µs)	From the Sync Advanced panel of the Tag Protocol page: With Custom Sync Timing enabled, enter sync frame start delay in us.	User with Change Configuration permission	SYNFSD	0	0 us – 255 µs	This value specifies how long the Reader will delay from the rising edge of the sync pulse to the rising edge of the trigger pulse in the frame.
Sync Delay (ns)	From the Sync Advanced panel of the Tag Protocol page: Enter sync delay in ns.	User with Change Configuration permission	SYNCDL	0	0 - 10000ns	This value specifies, in 100 nanosecond (ns) increments, how long the Reader will wait after Reader-to-Reader synchronization has occurred before firing the next tag acquisition sequence. This value should be calculated based on the length of the Sync Cable.
Enable Sync-on-Skipped-Sync Sequencing	From the Sync Advanced panel of the Tag Protocol page: Set toggle switch to ON to enable.	User with Change Configuration permission	SYNSKP	0	0-1	Instruct the reader to search for the missing sync sequence to indicate when the protocol synchronization is to occur. Note: This feature should be used when more than 3 protocols are selected in the multi-tag acquisition sequence.
ATA Frame Length (ms)	From the ATA Advanced panel of the Tag Protocol page:	User with Change Configuration permission	ATA_FL	19.5 (6)	16.5 ms (0) – 21.5 ms (10) (in 0.5 ms steps)	Specifies the length of the ATA frame in milliseconds (ms).

Command	How to execute	Who can execute	Prmtr. Name	Default Value	Prmtr. Range	Purpose of command
	Select frame length in ms from the drop-down list.					
ATA Hold-Off Delay Enable	From the ATA Advanced panel of the Tag Protocol page: Set toggle switch to ON to enable delay.	User with Change Configuration permission	ATAHOE	0	0 - 1	Controls whether ATA CW transmission is held off at the start of the ATA frame for a period of time in order to provide a sufficient gap in air time from the end of transmission of the previous timeslot.
ATA Hold-Off Delay (µs)	From the ATA Advanced panel of the Tag Protocol page: Select hold off delay in us from drop-down list.	User with Change Configuration permission	ATAHOD	600 us (3)	0 us (0) - 1400 µs (7) (in 200 µs steps)	Specifies how long the ATA CW transmission is delayed from the start of the ATA frame in order to provide a sufficient gap in air time from the previous timeslot.
Lane Controller Page						
LC Ethernet TCP-Socket Local Port	On the Lane Controller page: Keep the default value if necessary.	User with Change Configuration permission	LcEtPn	default: 6666	min: 1024 max: 65535	Used to select the local TCP Protocol Port Number that the Reader will listen on to accept incoming TCP connections from the Lane Controller.
LC Ethernet TCP-Socket Timeout (ms)	On the Lane Controller page:	User with Change Configuration permission	LcEtTo	500	100-5000	Sets the timeout for a response from the LC via the LC Ethernet network. To determine if there is an Ethernet communication problem between the Reader and the LC.

Command	How to execute	Who can execute	Prmtr. Name	Default Value	Prmtr. Range	Purpose of command
	With at least one RF Channel configured to send data to the LC via Ethernet, type a time in milliseconds in field.					
LC Ethernet Connection Mode	On the Lane Controller page: Select option in connection mode.	User with Change Configuration permission	LcECnM	Standard (Legacy)	Standard (Legacy) TCP - Long Lived	Specifies how the Reader will connect to the Lane Controller. Select 'Standard (Legacy)' for the traditional 'Open-Send-Close' TCP Socket paradigm. Select 'TCP - Long Lived' for long-lived TCP/IP socket connections with the Lane Controller. Note that there are message encapsulation, connection establishment, and protocol changes as well. refer to ICD 360467-122 for details.
Send Ethernet Heartbeats	On the Lane Controller page: With LC Ethernet Connection Mode in TCP - Long Lived, set Toggle switch to enable heartbeat.	User with Change Configuration permission	LCHTBT	1	0-1	Used to detect communication problems between the Reader and the LC. Disabled: no heartbeat messages are sent to LC. Enabled: causes the Reader to send heartbeat messages to the LC.
Ethernet Heartbeat Interval (sec)	On the Lane Controller page: With send heartbeat messages enabled, enter interval time in seconds.	User with Change Configuration permission	LCHBTM	2	1-30	Sets the heartbeat message interval, i.e. how often heartbeat messages are sent from the Reader to the LC.

Command	How to execute	Who can execute	Prmtr. Name	Default Value	Prmtr. Range	Purpose of command
Destination	On the LC Destination panel on the Lane Controller page: Select checkbox to enable Ethernet and/or Dual Ethernet for each RF channel	User with Change Configuration permission	LCDEST	1	0 - 15	Specifies the type of interface (Ethernet, Dual Ethernet) communication with the lane controller.
Destination IP Address and Port	On the LC Destination panel on the Lane Controller page: Select Ethernet checkbox and input ip address in field.	User with Change Configuration permission	LCIPPT	N/A	N/A	This specifies the destination IP address and port.
Dual Destination IP Address and Port	On the LC Destination panel on the Lane Controller page: In Advanced mode: select Dual Ethernet checkbox and input ip address in field.	User with Change Configuration permission	LC2IPP	N/A	N/A	This specifies the Dual Destination IP address and port.
Tertiary Ethernet Destination IP Address (IREADs only)	From the LC tab on the Configure panel:	User with Change Configuration permission	LC3IPP	N/A	N/A	This specifies the Tertiary Destination IP address and port. Note: Only IREAD reports are sent over this link.

Command	How to execute	Who can execute	Prmtr. Name	Default Value	Prmtr. Range	Purpose of command
Voting Report	On the LC Reporting panel on the Lane Controller page: Set toggle switch to ON to enable report type for all tag protocols.	User with Change Configuration permission	VOTRPT	1	0-1	Used to choose to send a voting report
Initial Read (IREAD) Report	On the LC Reporting panel on the Lane Controller page: Set toggle switch to ON to enable report type for all tag protocols.	User with Change Configuration permission	INIRPT	0	0-1	Used to choose to send or not to send an initial report the first time a new tag is seen
Raw Handshake Report	On the LC Reporting panel on the Lane Controller page: Set toggle switch to ON to enable report type for all tag protocols.	User with Change Configuration permission	RAWRPT	0	0-1	Used to send a handshake to the LC for every tag read
Post-Capture-Zone Report	On the LC Reporting panel on the Lane Controller page: Set toggle switch to ON to enable report type for all tag protocols.	User with Change Configuration permission	PCZRPT	0	0-1	Used to choose to generate and potentially send a post-capture-zone report

Command	How to execute	Who can execute	Prmtr. Name	Default Value	Prmtr. Range	Purpose of command
Post-Capture-Zone Voting Time (multiples of VT)	On the LC Reporting panel on the Lane Controller page: With Post-Capture-Zone Report enabled, input multiple count for all tag protocols.	User with Change Configuration permission	PCZRTx	1	1 - 5	Specifies how many multiples of VT to wait after voting time to perform post-capture-zone report calculations.
Minimum Speed Report sample count (ms)	On the LC Reporting panel on the LC page	User with Change Configuration permission	EVSMSS	1	1 - 10	The reader sets the ZC field to 9999 in the EVS report when the sample count is less than the specified minimum.
Estimated-Vehicle-Speed (EVS) Report	On the LC Reporting panel on the Lane Controller page: Set toggle switch to ON to enable report type for all tag protocols.	User with Change Configuration permission	EVS RPT	0	0-1	Used to choose to generate and send an Estimated Vehicle Speed report
Status Reports	On the LC Extended Reporting panel on the Lane Controller page: Click on checkbox to enable /disable what to be included in report.	User with Change Configuration permission	EIR_SR	0	0-1	Specifies which Extended Information values are to be included in Status Reports sent to the Lane Controller.

Command	How to execute	Who can execute	Prmtr. Name	Default Value	Prmtr. Range	Purpose of command
Transaction Reports (Initial-Read, Voting, Post-Capture, Est.Veh.Speed)	On the LC Extended Reporting panel on the Lane Controller page: Click on checkbox to enable /disable what to be included in report.	User with Change Configuration permission	EIR_TN	0	0-1	Specifies which Extended Information values are to be included in Transaction Reports (Initial Read, Voting, Post-Capture, and/or Estimate Vehicle Speed) reports sent to the Lane Controller.
Raw Handshake Reports	On the LC Extended Reporting panel on the Lane Controller page: Click on checkbox to enable /disable what to be included in report.	User with Change Configuration permission	EIR_RH	0	0 - 31	Specifies which Extended Information values are to be included in Raw Handshake reports sent to the Lane Controller.
6B Transponder Data Format	On the LC Report Format panel on the Lane Controller page: Select format from the drop-down list.	User with Change Configuration permission	I6BFmt	Standard UID (0)	Standard UID (0) eATA 8-bit ASCII Alphanumeric (2) Combined UID+eATA (3)	Specifies the type of 6B report formatting to employ
Suppress 6B Clone Tags	On the LC Report Format panel on the Lane Controller page: Set toggle switch to ON to suppress report.	User with Change Configuration permission	NO6BCT	1	0 - 1	If enabled, instructs the Reader to suppress the reporting of 6B Clone Tags.

Command	How to execute	Who can execute	Prmtr. Name	Default Value	Prmtr. Range	Purpose of command
ATA Tag Report Filtering/Threshold:	On the LC Report Format panel on the Lane Controller page: From the LC tab on the Configure panel, select the ATA Tag Report Filtering/Threshold checkbox	User with Change Configuration permission	ATAFLT	0	Disabled 0 Enabled:1 Read Enabled:2 Reads Enabled:3 Reads	Use this option to perform filtering of ATA tag reports (Voting, Post Capture) based on a set handshake count threshold. Sets the minimum number of ATA tag reads that must occur on any given channel before a given tag is processed and/or reported to the Lane Controller. Set appropriately, this feature can help reduce the incidence of ATA 'Phantom' reads/reports.
Verify ATA Data CRC:	On the LC Report Format panel on the Lane Controller page:	User with Change Configuration permission	ATAVDC	1	0 - 1	If enabled, instructs the Reader to perform a CRC validation check on the received ATA data. If the incoming data does not pass the CRC check, handshake messages, if enabled, may be flagged as invalid, or suppressed entirely.
Suppress ATA Bad CRC Handshake Reports	On the LC Report Format panel on the Lane Controller page: Set toggle switch to ON to suppress report.	User with Change Configuration permission	NOATAC	0	0 - 1	Enable this option to suppress the reporting of ATA Handshake Reports that have failed an ATA Data-CRC check.
Suppress ATA 'Phantom' Handshake Reports	On the LC Report Format panel on the Lane Controller page: Set toggle switch to ON to suppress report.	User with Change Configuration permission	NOATAP	0	0 - 1	Enable to suppress the reporting of ATA 'Phantom' Read Handshake Reports. A read is deemed a 'Phantom' if the ATA Frame-Check fails and/or the reader is unable to extract a valid serial number from the data.

Command	How to execute	Who can execute	Prmtr. Name	Default Value	Prmtr. Range	Purpose of command
Dual-Destination Buffering Mode	On the LC Advanced panel on the Lane Controller page: Select mode from the drop-down list.	User with Change Configuration permission	LCDDBM	Fully Independent	Standard (Legacy) Fully Independent	Specifies how Dual-Destination message buffering is to be performed. Select 'Standard (Legacy)' mode to have buffering start when both Ethernet and Dual-Ethernet links are down, buffered messages are drained when both Ethernet and Dual-Ethernet links are resumed. Set to 'Fully Independent' to have fully independent buffering between the Ethernet and Dual-Ethernet links when link failures occur.
Status Message Buffering	On the LC Advanced panel on the Lane Controller page: Set toggle switch to ON to enable buffering.	User with Change Configuration permission	LcStBf	0	0-1	If enabled, instructs the Reader to buffer status messages in the event of a communications link loss with the Lane Controller.
Initial Read Report (IREAD) Message Buffering	On the LC Advanced panel on the Lane Controller page: Set toggle switch to ON to enable buffering.	User with Change Configuration permission	LcIrBf	0	0-1	If enabled, the Reader buffers Initial Read Report (IREAD) messages in the event of a communications link loss with the the Lane Controller.
Departure Report Message Buffering	On the LC Advanced panel on the Lane Controller page: Set toggle switch to ON to enable buffering.	User with Change Configuration permission	LcDrBf	0	0-1	If enabled, the Reader buffers Departure Report messages in the event of a communications link loss with the the Lane Controller.

Command	How to execute	Who can execute	Prmtr. Name	Default Value	Prmtr. Range	Purpose of command
TCP (Long-Lived) Keepalive Time (sec)	On the LC Advanced panel on the Lane Controller page: Input time in seconds.	User with Change Configuration permission	LcTKaT	10	5-7200	Specifies the time (in seconds) a TCP Long-Lived connection between the Reader and the Lane Controller needs to remain idle before the Reader begins sending TCP Keepalive probes.
TCP (Long-Lived) Keepalive Probes	On the LC Advanced panel on the Lane Controller page: Input number in field.	User with Change Configuration permission	LcTKaP	3	1-10	For TCP Long-Lived Connections, specifies the maximum number of TCP Keepalive probes the Reader should send before dropping the connection.
TCP (Long-Lived) Keepalive Interval (sec)	On the LC Advanced panel on the Lane Controller page: Input time in seconds.	User with Change Configuration permission	LcTKaI	2	1-100	For TCP Long-Lived Connections, specifies the time (in seconds) between individual TCP Keepalive probes.
TCP (Long-Lived) User Timeout (msec)	On the LC Advanced panel on the Lane Controller page: Input timeout in milliseconds.	User with Change Configuration permission	LcTUTo	5000	5000-60000	For TCP Long-Lived Connections, specifies the maximum time (in milliseconds) that transmitted data may remain unacknowledged by the Lane Controller (at the TCP layer) before the Reader will forcibly close the connection. This feature can be used to detect the presence of link drops (e.g. cable disconnects and/or peer crashes), especially if Ethernet Heartbeats have been disabled.

Command	How to execute	Who can execute	Prmtr. Name	Default Value	Prmtr. Range	Purpose of command
0 - Interior FPT Delay [ms]	On the LC Latency by Tag Type panel on the Lane Controller page: Enter a time (in milliseconds) in the 0-Interior FPT Delay field	User with Change Configuration permission	LYCTL0	0	0-5000	Sets report delay time in milliseconds for Interior FPT OBUs (Type 0) Used to slow down the transaction report of Type 0 OBUs to the LC for those legacy sites where the LC is expecting BADGER Reader timing
1 - Exterior FPT Delay [ms]	On the LC Latency by Tag Type panel on the Lane Controller page: Enter a time (in milliseconds) in the Exterior FPT Delay field	User with Change Configuration permission	LYCTL1	0	0-5000	Sets report delay time in milliseconds for Exterior FTP OBUs (Type 1). Used to slow down the transaction report of Type 1 OBUs to the LC for those legacy sites where the LC is expecting BADGER Reader timing
2 - Exterior LPT Delay [ms]	On the LC Latency by Tag Type panel on the Lane Controller page: Enter a time (in milliseconds) in the Exterior LPT Delay field..	User with Change Configuration permission	LYCTL2	0	0-5000	Sets report delay time in milliseconds for Exterior LPT OBUs (Type 2). Used to slow down the transaction report of Type 2 OBUs to the LC for those legacy sites where the LC is expecting BADGER Reader timing
3 - LCD Display Delay [ms]	On the LC Latency by Tag Type panel on the Lane Controller page: Enter a time (in milliseconds) in the LCD Display Delay field..	User with Change Configuration permission	LYCTL3	0	0-5000	Sets report delay time in milliseconds for LCD Display OBUs (Type 3). Used to slow down the transaction report of Type 3 OBUs to the LC for those legacy sites where the LC is expecting BADGER Reader timing

Command	How to execute	Who can execute	Prmtr. Name	Default Value	Prmtr. Range	Purpose of command
4 - Commercial Vehicle (CVO) Delay [ms]	On the LC Latency by Tag Type panel on the Lane Controller page: Enter a time (in milliseconds) in the Commercial Vehicle (CVO) Delay field..	User with Change Configuration permission	LYCTL4	0	0-5000	Sets report delay time in milliseconds for CVO OBUs (Type 4). Used to slow down the transaction report of Type 4 OBUs to the LC for those legacy sites where the LC is expecting BADGER Reader timing
5 - OBU Feedback Tag Delay [ms]	On the LC Latency by Tag Type panel on the Lane Controller page: Enter a time (in milliseconds) in the OBU Feedback Tag Delay field..	User with Change Configuration permission	LYCTL5	0	0-5000	Sets report delay time in milliseconds for Feedback OBUs (Type 5). Used to slow down the transaction report of Type 5 OBUs to the LC for those legacy sites where the LC is expecting BADGER Reader timing
6 - HOT Tag Delay [ms]	On the LC Latency by Tag Type panel on the Lane Controller page: Enter a time (in milliseconds) in the HOT Tag Delay field..	User with Change Configuration permission	LYCTL6	0	0-5000	Sets report delay time in milliseconds for HOT OBUs (Type 6). Used to slow down the transaction report of Type 6 OBUs to the LC for those legacy sites where the LC is expecting BADGER Reader timing.

Command	How to execute	Who can execute	Prmtr. Name	Default Value	Prmtr. Range	Purpose of command
LC Retry Timeout	From the LC Serial panel on the Lane Controller page: Enter a time, in milliseconds, in the LC Retry Timeout field.	User with Change Configuration permission	PROTTO	1000	50-1000	Sets the LC retry timeout to set the time that the Reader waits for LC confirmation before resending data . (Serial link only)
Serial Port State	From the LC Serial panel on the Lane Controller page: Select the Serial Port State check box for the required LPM COM port.	User with Change Configuration permission	COM_ST	1	0-1	Disabled: LCM COM port disabled Enabled: LCM COM port enabled to communicate with LC to enable or disable communications on each LPM COM port
Baud Rate	From the LC Serial panel on the Lane Controller page: With the Serial Port State enabled, select the desired Baud Rate from the drop-down box.	User with Change Configuration permission	COM_BR	19200	9600 19200 38400 57600 115200	Sets the LPM baud rate for individual COM ports to configure the LPM baud rate on a port by port basis

Command	How to execute	Who can execute	Prmtr. Name	Default Value	Prmtr. Range	Purpose of command
Data Bits	From the LC Serial panel on the Lane Controller page: With the Serial Port State enabled, select the desired Data Bits from the drop-down box.	User with Change Configuration permission	COMBTZ	8	5 6 7 8	sets the LPM data bits for individual COM ports to configure the LPM data bits on a port by port basis
Parity	From the LC Serial panel on the Lane Controller page: With the Serial Port State enabled, select the desired Parity from the drop-down box.	User with Change Configuration permission	COMPTY	None	None Even Odd	sets the LPM parity for individual COM ports to configure the LPM parity on a port by port basis
Stop Bits	From the LC Serial panel on the Lane Controller page: With the Serial Port State enabled, select the desired Stop Bits from the drop-down box.	User with Change Configuration permission	COMSTP	1	1-2	sets the LPM stop bits for individual COM ports to configure the LPM stop bits on a port by port basis

Command	How to execute	Who can execute	Prmtr. Name	Default Value	Prmtr. Range	Purpose of command
Lane Assignment Page						
TDM 6B 6C Title21 ATA SeGo	On the Lane Assignment page: Select First to Read/Program or Majority from the Lane Assignment Algorithm box.	User with Change Configuration permission	VTALGO VTAG6B VTAG6C VTAGAG VTAGAA VTAGSG	Majority	First to read/program Majority	Runs the selected tag (channel) assignment algorithm. Sets which algorithm is used for determining OBU lane assignment between channels. Majority voting make channel assignment decision based on handshake count from each channel at time of voting.
Communication Method	From the Inter-Reader panel on the Lane Assignment page: Select Disabled, Legacy CRA, or Ethernet.	User with Change Configuration permission	MULTRD	Disabled	Disabled Legacy CRA Ethernet	Disabled: Reader is not set to communicate with other Readers. Legacy CRA: Voting between Readers relies on writing to TDM tags. Ethernet: Voting between Readers relies on communicating between readers on IR network. Sets how Readers communicate when determining lane assignments between multiple Readers

Command	How to execute	Who can execute	Prmtr. Name	Default Value	Prmtr. Range	Purpose of command
Cross-Reader Reporting	From the Inter-Reader panel on the Lane Assignment page, with Legacy CRA or Ethernet communication method enabled: Select Disabled, Report All, or Report Non-Zero from the Cross-Reader Reporting box.	User with Change Configuration permission	CRARPT	0	0 Report All Report Non-Zero	Disabled: Reader is not set to communicate with other Readers. Report All results in all transactions being sent to the LC Report Non-Zero informs the LC of suppressed transactions To set which transactions are sent to LC in multi-reader configurations
Align tag-timeout expiry between readers	From the Inter-Reader panel on the Lane Assignment page: With Ethernet communication method enabled: Toggle switch to enable /disable.	User with Change Configuration permission	IR_TTO	1	0-1	This helps to align Tag Timeout events between readers to prevent missing transactions due to TTO expired on one reader but not the other.
IRIF Timeout [ms] (make sure the TTO values of all IRIF readers are the same)	From the Inter-Reader panel on the Lane Assignment page, with Ethernet communication method enabled: Enter a time, in milliseconds, in the IRIF Timeout field.	User with Change Configuration permission	IRIFTO	50	30-5000	Sets IRIF timeout time Sets the threshold for determining an IR network problem and enable a switchover if enabled

Command	How to execute	Who can execute	Prmtr. Name	Default Value	Prmtr. Range	Purpose of command
Enable Left Reader	From the Inter-Reader panel on the Lane Assignment page, with Ethernet communication method enabled: Select the Left Reader switch.	User with Change Configuration permission	LEFTRD	0	0-1	Disabled: Reader does not coordinate voting with Reader covering lanes to the left. Enabled: Reader coordinated lane assignment voting with Reader covering lanes to the left. Tells this Reader if there is another Reader in the IR network that is covering ORT lanes that are to the left of the lanes this Reader is covering.
Left Reader IP	From the Inter-Reader panel on the Lane Assignment page, with Ethernet communication method enabled, with the Left Reader enabled, Enter the IP address of the left Reader in the Left Inter-Reader alias field.	User with Change Configuration permission	LEFTIP	0.0.0.0	N/A	Informs the Reader what the IP address is of the Reader covering lanes to the left of this Reader. To provide the Reader with the IP address of the left Reader in the IR network.
Enable Right Reader	From the Inter-Reader panel on the Lane Assignment page, with Ethernet communication method enabled: Select the Right Reader switch.	User with Change Configuration permission	RGHTRD	0	0-1	Disabled: Reader does not coordinate voting with Reader covering lanes to the right. Enabled: Reader coordinated lane assignment voting with Reader covering lanes to the right. Tells this Reader if there is another Reader in the IR network that is covering ORT lanes that are to the right of the lanes this Reader is covering.

Command	How to execute	Who can execute	Prmtr. Name	Default Value	Prmtr. Range	Purpose of command
Right Reader IP	From the Inter-Reader panel on the Lane Assignment page, with Ethernet communication method enabled, with the Right Reader enabled, Enter the IP address of the right Reader in the Right Inter-Reader alias field.	User with Change Configuration permission	RGHTIP	0.0.0.0	N/A	Informs the Reader what the IP address is of the Reader covering lanes to the right of this Reader. To provide the Reader with the IP address of the right Reader in the IR network
Inter-Reader alias	From the Inter-Reader panel on the Lane Assignment page: With Ethernet communication method enabled: Enter IP address of this Reader in field.	User with Change Configuration permission	READIP	192.168.0.151	N/A	Assign a unique IPv4 address to the reader as a whole. This address is used for inter-reader communication (e.g. inter reader voting). If there is only one reader at a site, this can be set to 0.0.0.0

Command	How to execute	Who can execute	Prmtr. Name	Default Value	Prmtr. Range	Purpose of command
Ethernet 2 IP Address:	From the Inter-Reader panel on the Lane Assignment page, with Ethernet communication method enabled: Type an ETHERNET 2 port IP address in the Ethernet 2 IP Address field..	User with Change Configuration permission	PRIMIP	192.168.0.50 Primary 192.168.0.51 Secondary	N/A	Used to assign a unique IPv4 address (e.g. 192.168.0.50) to the right hand side (prime) side of the reader. Used to specify an appropriate ETHERNET 2 IP address when configuring an IR network. Note: This address should be provided by the SI network planner.
Enable Early Read Logic	On the TDM Early Read Logic panel on the Lane Assignment page, check the Enable switch	User with Change Configuration permission	EREAD_	0	0 - 1	Can improve TDM programming success rate by detecting early reads and delaying voting according to the extent (i.e., time gap) of the early read.
Max Delay (ms)	On the TDM Early Read Logic panel on the Lane Assignment page, Enter value in Max Voting Delay field	User with Change Configuration permission	ERDMAX	1000	1 - 1000	Specifies the maximum time in milliseconds allowed to delay voting
Min Gap Size (ms)	On the TDM Early Read Logic panel on the Lane Assignment page, Enter value in Min Early Read Gap Size field,	User with Change Configuration permission	ERDGAP	50	1 - 10000	An early read Specifies the minimum allowed gap size

Command	How to execute	Who can execute	Prmtr. Name	Default Value	Prmtr. Range	Purpose of command
Voting Delay Gap Scaling Factor (%)	On the TDM Early Read Logic panel on the Lane Assignment page, Enter value in Voting Delay Gap Scaling Factor field,	User with Change Configuration permission	ERDVSF	100	0 - 500	Specifies the voting delay scaling factor to apply
Minimum Post Gap HS Ratio (0-100%)	On the TDM Early Read Logic panel on the Lane Assignment page, Enter value in Minimum Post Gap HS Ratio field,	User with Change Configuration permission	ERDHSR	50	0 - 100	Specifies the minimum post gap to cumulative HS ratio (e.g. 50% means at least half of the HS on any channel must be after the RF gap).
Enable Low Read Logic	On the TDM Low Read Logic panel on the Lane Assignment page, check the Enable switch	User with Change Configuration permission	LWREAD	0	0 - 1	Delays voting if a long RF gap right before voting is detected.
Max Delay (ms)	On the TDM Low Read Logic panel on the Lane Assignment page, Enter value in Max Voting Delay field	User with Change Configuration permission	LRDMAX	1000	1 - 10000	Specifies the maximum time in milliseconds allowed to delay voting

Command	How to execute	Who can execute	Prmtr. Name	Default Value	Prmtr. Range	Purpose of command
Min Gap Size (ms)	On the TDM Low Read Logic panel on the Lane Assignment page, Enter value in Min Low Read Gap Size field	User with Change Configuration permission	LRDGAP	50	1 - 10000	Specifies the minimum allowed gap size
Voting Delay Gap Scaling Factor (%)	On the TDM Low Read Logic panel on the Lane Assignment page, Enter value in Voting Delay Gap Scaling Factor field	User with Change Configuration permission	LRDVSF	100	0 - 500	Specifies the voting delay scaling factor to apply
Channels Page						
RF Channel Number	On the Channels panel on the Channels page: Enter a value in the Number of Channels field.	User with Change Configuration permission	N/A	N/A	1-8	Enter a value from 1 to 8

Command	How to execute	Who can execute	Prmtr. Name	Default Value	Prmtr. Range	Purpose of command
RF State	On the Channels panel of the Channels page: Select one of the choices offered from the drop down menu for every appropriate channel.	User with Change Configuration permission	RF_STS	Offline	Offline Active Guard No Module	Offline means the MRFM-S (Plus) module is off. Active means the MRFM-S (Plus) module is on and reports transactions on this channel. Guard means MRFM-S (Plus) module is on, but transactions assigned to this channel are not reported. No Module Intentionally indicates an empty slot in the RF rack for this channel. This will prevent false module status errors. Active or Guard status is applied to all protocols.
Channel Weight [%]	On the Channels panel of the Channels page, with Advanced switch ON: Type the Channel Weight as a percent in the appropriate fields.	User with Change Configuration permission	RFGWGT	100	0-100	Enter a value from 0 to 100. At lane assignment time, the reader applies the weighting factor to all channels seeing the same transponder in a group. A channel weight of 50 means only half of the handshakes are used in comparing with adjacent channels. Typically a value other than 100 is used only for channels that straddle two physical lanes.
Group ID(voting)	On the Channels panel of the Channels page, with Advanced switch ON: Type the (voting) Group ID in the appropriate fields.	User with Change Configuration permission	RFGPID	0	0-7	By default all channels are in one group, such that any cross lane reads within the group generate only one transaction. By specifying different (voting) group IDs, multiple independent capture zones can be created. This is useful for certain applications.

Command	How to execute	Who can execute	Prmtr. Name	Default Value	Prmtr. Range	Purpose of command
LPT/FME Voting time [ms]	On the Channels panel of the Channels page: Type the voting time in the appropriate fields.	User with Change Configuration permission	LPTVTO	300	0-9999	Specifies the time after the initial entry of the transponder into the capture zone at which a VOTE report is generated. This is a trade-off between lane assignments versus latency. A value of 0 means no voting, subject to the Programming Timeout parameter. Specific to [L]icense [P]late [T]ags and (F)ront (M)ount (E)xterior tags only.
Voting Time (all other tag types) [ms]	On the Channels panel of the Channels page: Type the Voting Time for all other tag types in the appropriate fields.	User with Change Configuration permission	VOTETO	100	0-9999	Specifies the time after the initial entry of the transponder into the capture zone at which a VOTE report is generated. A value of 0 means no voting, subject to the Programming Timeout parameter.
Dynamic Voting Control	On the Channels panel of the Channels page, with Advanced switch ON: Select Disabled or Reader from the Dynamic voting control drop-down box (LC Speed and LC Ends are not supported).	User with Change Configuration permission	DVCTRL	Disabled	Disabled Reader LC Speed LC End	Disabled: reader uses the fixed voting time Reader: the Reader monitors the average time an OBU is in the capture zone and uses this time to determine an appropriate voting time. LC Speed: not currently supported. LC End: not currently supported. To set type of voting control.

Command	How to execute	Who can execute	Prmtr. Name	Default Value	Prmtr. Range	Purpose of command
Dynamic Voting Sample Size	On the Dynamic Voting panel of the Channels page: With Dynamic Voting Control set to Reader, enter the desired number of samples.	User with Change Configuration permission	DVSPSZ	20	1-50	Sets the sample size used in the Dynamic Voting Calculation. To configure the Dynamic Voting Control calculation. The number entered here is the number of previous transactions used when calculating the average voting time.
Dynamic Voting Threshold [%]	On the Dynamic Voting panel of the Channels page: With Dynamic Voting Control set to Reader, enter the voting threshold percentage in the Dynamic Voting Threshold field.	User with Change Configuration permission	DVTHSD	20	5-100	Sets the voting threshold percentage To configure when the average Voting time is adjusted. The Voting time will only be updated when the Reader determines the percent change is larger than the threshold entered here.
Dynamic Voting Capture Zone Span Multiplier	On the Dynamic Voting panel of the Channels page: With Dynamic Voting Control set to Reader, enter a voting time multiplier in the Dynamic Voting Capture Zone Span Multiplier field.	User with Change Configuration permission	DVCZTM	2	1-5	Sets the Capture Zone Span Time multiplier Determines when the Reader checks for voting time updates.

Command	How to execute	Who can execute	Prmtr. Name	Default Value	Prmtr. Range	Purpose of command
Transponder Timeout	On the Group panel of the Channels page: Enter a time, in seconds, in the Transponder Timeout field.	User with Change Configuration permission	GRPTTO	300	1-300	set the transponder timeout time to set the amount of time an OBU must be out of a capture zone before communication with the OBU is reported as a new transaction
Programming Timeout (ms)	On the Group panel of the Channels page: Enter a time in ms for each voting group.	User with Change Configuration permission	GRPPTG	300	1-300	This field will be shown when any channel has Voting time or LPT/FME Voting time equals to 0. If programming is not successful the reader will keep trying until the programming timeout value (in milliseconds) is reached.
Time Page						
Network Time Protocol	On the Time page: Set toggle switch to ON to enable NTP.	User with Change Configuration permission	NTP__	0	0-1	Enables or disables setting the Reader time via an NTP server to ensure readers are time synced to a time server.
NTP time offset warning threshold (ms)	On the Time page: With NTP enabled, Input threshold in milliseconds.	User with Change Configuration permission	NTPMAX	20	1-100	Specify a maximum threshold (default 20 ms) for the largest NTP time offset tolerated in the system. When NTP is enabled, the reader periodically checks its NTP time offset, and if it is greater than the threshold, change the NTP status parameter to one of the Alarm values. An alert is also shown in the UI banner.

Command	How to execute	Who can execute	Prmtr. Name	Default Value	Prmtr. Range	Purpose of command
NTP Server 1, 2, 3 and 4	On the Time page: With NTP enabled, enter three different valid NTP server IP address in the NTP Server fields.	User with Change Configuration permission	NTP__1 NTP__2 NTP__3 NTP__4	N/A	N/A	Sets the NTP server IP addresses. Provides the Reader with four NTP servers it can access to accurately maintain time with other Readers in an IR network.
NTP peers 1, 2, 3, 4, 5	On the Time page: With NTP enabled, enter NTP peers.	User with Change Configuration permission	NTPPR1 NTPPR2 NTPPR3 NTPPR4 NTPPR5	N/A	N/A	
Set Reader Time Zone	On the Time page: Select time zone in the drop-down list.	User with Change Configuration permission	T_ZONE	UTC	N/A	Set time zone.
Set Reader Date and Time	On the Time page: With NTP disabled, Click the edit box to set date and time to the Reader, then	User with Change Configuration permission	N/A	N/A	N/A	Manually set the Reader time.

Command	How to execute	Who can execute	Prmtr. Name	Default Value	Prmtr. Range	Purpose of command
	click the SET TIME button to confirm.					
Compare Page						
Set Configuration Aligned	On the Compare page: Click on Keep aligned with primary side switch.	User with Change Configuration permission	EKOCFG	1	0 - 1	0 – Automatic mirroring the configuration is disabled. 1 – Automatic mirroring the configuration is enabled.
Configuration Compare Request	On the Compare page: Click on  button	Anyone	N/A	N/A	N/A	Request configuration compare between Primary and Secondary sides of the reader.
Save /Load Configuration Page						

Command	How to execute	Who can execute	Prmtr. Name	Default Value	Prmtr. Range	Purpose of command
Save Config	On the Save/Load Configuration page: Click the Download reader configuration icon to save.	User with Change Configuration permission	N/A	N/A	N/A	Save current Reader configuration into a file. The file can then be reloaded later or used to configure other Readers.
Upload Config	On the Save/Load Configuration page: Click the Load a configuration file icon to load.	User with Change Configuration permission	N/A	N/A	N/A	Load a previously saved reader configuration file from your device to the reader. The reader network settings (see General page) and site name are not changed.
Reset Config	On the Save/Load Configuration page: Click the Reset reader configuration to defaults icon to reset.	User with Change Configuration permission	N/A	N/A	N/A	Restore all Reader configuration settings to the factory default values except for the reader network settings (see General page) and site name.

Reader Software Page

Command	How to execute	Who can execute	Prmtr. Name	Default Value	Prmtr. Range	Purpose of command
Upload File	On the Reader Software page: Click the Load icon and select a file to upload.	User with Manage Software permission	N/A	N/A	N/A	Upload a software/firmware version to the Reader so that it can be activated later.
Activate Software Version	On the Reader Software page: Select version in the list of Available Software Versions, then click the Activate icon.	User with Manage Software permission	N/A	N/A	N/A	Activate the selected software/firmware version. This will also deactivate the currently running software/firmware version.
Delete Software Version	On the Reader Software page: Select version in the list of Available Software Versions, then click the Delete icon.	User with Manage Software permission	N/A	N/A	N/A	Delete the selected software/firmware version. This is delete an inactive, non-factory software/firmware version that is no longer required to free up space for newer versions.

Users Page

Command	How to execute	Who can execute	Prmtr. Name	Default Value	Prmtr. Range	Purpose of command
Create New User	On the Users page: Click the Add User icon to create new user.	User with Admin User permission	N/A	N/A	N/A	Create a new user.
Change Permissions	On the Users page: Select a user name in the user list and click the Edit User icon to change permissions.	User with Admin User permission	N/A	N/A	N/A	Enable any permission changes for a given user except the user with name as "admin".
Change Password	On the Users page: Select the user name of the currently logged in user and click the Change Password icon.	The logged in user	N/A	N/A	N/A	Change the password of the user currently logged into the CTM web interface.
Reset Password	On the Users page: Select a user name in the user list and click the Reset Password icon.	User with Admin User permission	N/A	N/A	N/A	Reset a user's password to "password" and let the user to create a new password if they have forgotten their existing one.
Delete User	On the Users page: Select a user name in the user list and click the Delete User icon.	User with Admin User permission	N/A	N/A	N/A	Remove a user who is no longer required to access the CTM web interface.

Command	How to execute	Who can execute	Prmtr. Name	Default Value	Prmtr. Range	Purpose of command
Logs Page						
Delete All Logs	On the Logs page: Click the Delete All Logs icon.	User with Manage Logs permission	N/A	N/A	N/A	Deletes all logs.

This Page Intentionally Left Blank

MAINTENANCE INSTRUCTIONS

This Page Intentionally Left Blank

4. THEORY OF OPERATIONS

This section offers a more detailed overview of the Reader components than the introductory overview provided in Overview Section 2 page 23.

Multi-protocol Readers can communicate with both active and passive OBUs. The Reader uses a combination of **Time Division Multiplexed (TDM)** and **Frequency Division Multiplexed (FDM)** periods to read active and passive OBUs respectively.

Each MRFM-S (Plus) and antenna pair, referred to as a channel, creates an RF capture zone on the roadway. The antennas are usually situated to create overlapping capture zones between channels. One reader can support up to 8 channels. When required, multiple readers can be synced together to support additional channels.

The reader processes the OBU information and provides transaction reports to the Lane Controller interfaces. When required, the reader can write data to the OBU.

Active OBUs

Active OBUs are battery powered and transmit a signal to the Reader antennas. As a vehicle equipped with an active OBU approaches a toll plaza, the OBU receives a trigger signal from the Tx antenna. The OBU then starts transmitting data, which is received by the Rx antenna.

The MRFM-S (Plus) decodes the active OBU signal and passes the data to the CTM, which processes and logs the OBU data and then sends the information to the Lane Controllers (LCs). The Reader may also send data back to the active OBUs, such as an updated toll account balance.

Passive OBUs

Passive tags are not battery powered and cannot transmit a signal. As a vehicle equipped with a passive OBU approaches the antenna, the OBU receives a transmit signal from the antenna. This signal is then reflected from the passive OBU back to the antenna. The reflected signal is uniquely modulated by each passive OBU, allowing the OBU to be identified.

The MRFM-S (Plus) decodes the passive OBU signal and passes the data to the CTM which processes and logs the OBU data and then sends the information to the Lane Controllers (LCs).

Capture zones

The capture zone is the area of antenna RF coverage. An antenna can communicate with an OBU once the OBU enters the antenna's capture zone. These capture zones and the number of antennas required per lane varies depending on the site and/or lane configuration.

Note: Where Kapsch is responsible installation and tuning, installation on sites and lanes is assessed by Kapsch Personnel prior to deployment in order to validate customer expectations and performance.

Multi-protocol RF Module Smart

The Multi-protocol RF Module Smart (MRFM-S) and Multi-protocol RF Module Smart Plus (MRFM-S Plus) can handle **multiple passive tag protocols**; 6B (ISO 18000-6 Type B), 6C (ISO 18000-6 Type C), ATA (10374/ATA/AAR S-918), SeGo as well as the **active protocol** TDM.

The MRFM-S (Plus) design includes a software command for adjusting the transmitter peak output power.

ATTENTION: When installing or replacing an RF module, the lane should be re-tuned. A reader can only contain either MRFM-S or MRFM-S Plus modules but not both.

The RF Module transmits recovered OBU data as messages to the CGC. After the messages are processed by the CTM, a transaction message is normally sent to the LC.

Power Supply Module (PSM)

The PSM AC mains power requirement is 95-230VAC (60Hz+/-2 Hz) at 10A max input current.

The PSM is field replaceable and provides:

- A power switch and a 10A fuse
- +5V and +15V DC power outputs
- +5V and +15V LEDs to indicate power supply output status

In the redundant configuration, both the primary and secondary PSMs are normally powered on. The primary PSM provides power to the primary CTM and the secondary PSM provides power to the secondary CTM. Both PSMs share the RF module load.

In the event of failure of one PSM, an automatic switchover will occur and the redundant PSM provides all the power for the RF module load.

The PSMs are not interchangeable. The Primary and Secondary power supplies have different part numbers; a result of being physical mirror images of each other.

Each PSM has a mains power fuse on the front panel: Time lag, 10 A @ 250 V, UL rated.

The power supply distribution is shown in Figure 4-1, page 144.

Figure 4-1: Reader Power distribution

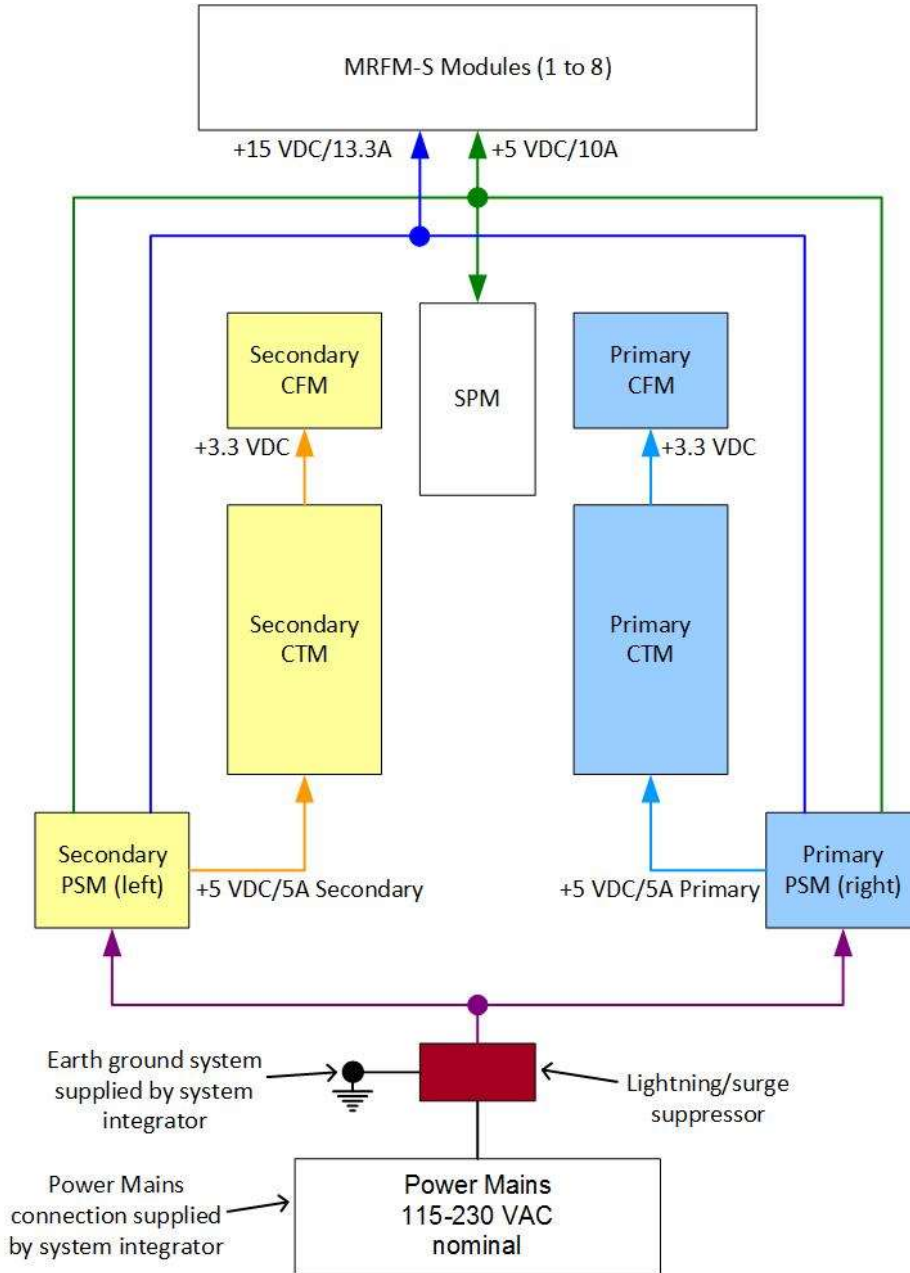

Note: Lightning/surge suppressor supplied by system integrator.

Lane Controller Port Module (LPM)

The LPM provides the serial communications connections between the CTM and the LC. The LC serial communication signals travel to/from the CTM CGC board via the Distribution Module (DSM) to the LPM serial port connectors. The LPM provides the 8 serial port connectors and integrated lightning protection. The LPM is field replaceable.

The MPR 2.4 is factory configured to support either an RS-232 or RS-422 interface. The data rate is configurable to standard rates up to 115.2 kbps.

Normally, each MRFM-S (Plus) channel is assigned a unique LPM COM port; however, the MRFM-S (Plus) channels can be multiplexed by assigning multiple RF channels to one LC serial port, as necessary.

For a description of the serial interface protocol between a Lane Controller and a Reader, refer to ICD 360467-122.

Sync Port Module (SPM)

The SPM provides a pathway for synchronization signals to and from both primary and secondary CTM MC boards via the DSM to the SPM 6-terminal block connector where the synchronization STAR network cables connect. The SPM is field replaceable.

A 4-Wire RS422 electrical connection at the front panel terminal block connects the SPM to the synchronization network.

There are no active components installed on the SPM.

A three-position toggle switch mounted on the SPM provides Auto, Primary and Secondary redundancy mode control signals via the DSM to the CTM.

Controller Module (CTM)

The CTM performs the Reader's transaction level processing for data received from and sent to the OBUs. The CTMs may be swapped without having to save the configuration file since the configuration data is stored in the CFMs mounted on the DSM.

The CTM as a whole unit is field replaceable.

Main Controller (MC)

The MC is an off-the-shelf EBX form-factor industrial single-board computer. This unit contains the CPU, memory and I/Os and is used to run the Reader software.

The MC receives recovered OBU information from its associated CGC and performs a lane assignment for each tag passing through the system via voting logic. It communicates with the LCs to report tag transactions, accepts configuration messages, and provides status messages via a legacy LC serial interface and/or an LC Ethernet interface. It detects and reports faults and can perform a switchover. It offers Reader configuration via a browser interface, storage for transaction buffering, event logging, and tag transaction and performance monitoring. It also supports remote software downloads. It provides Inter-Reader communications with up to

two other Readers, saves Reader configuration parameters to the primary and secondary CFM, manages the OBU Account Status file, and keeps log files for OBU transactions, system events, and trouble reports. For a description of the Ethernet interface protocol between a Lane Controller and a Reader, refer to ICD 360467-122.

Channel Group Controller Module (CGC)

The CGC is used as a scheduler, message buffer, and a controller. It schedules when the MRFM-S (Plus) operates, routes configuration data from the MC to the MRFM-S (Plus), and routes message data from the MRFM-S (Plus) to the MC. It also manages timing synchronization between readers and CTMs.

Configuration Module (CFM)

The CFM is a field replaceable PWA board. These non-volatile memory cards store the Reader configuration file. They are field-replaceable without using any tools.

Distribution Module (DSM)

The DSM provides interconnections between the plug-in modules in the Reader rack. It is not field-replaceable. The DSM:

- Provides locations for all plug-in Reader modules and the Lane Kit RF modules
- Distributes DC power from the PSMs to the necessary modules in the Reader rack
- Carries RF data and control signals between primary and secondary CTMs and all MRFM-S (Plus)s
- Carries synchronization and redundancy mode signals between primary and secondary CTMs and the SPM
- Carries data between primary and secondary CTMs and primary and secondary CFMs
- Carries data between primary and secondary CTMs and primary and secondary LPMs

Multiple reader synchronization

Readers must be synchronized under the following conditions.

- If they have overlapping capture zones,
- If they are connected in an IR network
- If Reader-to-Reader RF interference is present.

Sync is recommended for installations that are less than 600 feet apart. For distances above this up to the sync cable maximum distance (1500 ft) tests for in-band interference should be carried out to ensure no Reader-Reader interference occurs.



ATTENTION: To avoid interference and loss of data between adjacent reader, readers must be synced.

Tests should be carried out under live traffic conditions to ensure that RF signal reflections that come off moving vehicles do not cause interference.

If Reader-to-Reader RF interference exceeds the in-band limits then the Readers must be synchronized

CTM-to-CTM synchronization in Redundant Reader.

The following requirements apply to synchronization between Primary and Secondary CTMs.

- Synchronization between Primary and Secondary CTMs (intra-reader sync) occurs whenever the reader is configured for redundancy.
- Loss of CTM synchronization does not affect the synchronization of readers connected in a network (Reader-to-Reader synchronization).
- A redundant reader currently operating on the Primary CTM does not fall into the Reader-to-Reader Sync Recovery routine if synchronization is lost on the Secondary CTM and vice versa.
- If synchronization is lost between CTMs, a loss of redundant sync signal is reported.

Reader-to-Reader synchronization

Reader-to-Reader synchronization requires the following programmable options on the web interface:

- Synchronization Search Time (maps to sync frame timeout in MPR2)
- Synchronization Delay (new feature not supported in MPR2 used for cable delays)
- Synchronization Frame Start Delay
- Sync Recovery Time (currently hardcoded default 20ms in MPR2)
- Sync Recovery Attempt Limit (new feature not supported in MPR2)
- Sync on Skipped Sync Frame

Note: Reader-to-Reader Sync Recovery occurs on a loss of synchronization with the external reader network.

Synchronization search time

Synchronization search time indicates how long the reader waits for reader to reader sync before falling into synchronization recovery.

If the reader detects synchronization prior to the expiry of this timer, it exits search mode and performs one of the following actions.

- Falls into Synchronization Delay if programmed
- Falls into synchronization frame start delay if programmed
- Begins firing its frame sequence.

Synchronization delay

Synchronization delay indicates how long the reader holds its sync driver low after synchronization has occurred. This feature is used to calibrate out cable length delays.

If the reader detects that the sync bus is driven high prior to the expiry of this delay, the reader exits delay mode and performs one of the following actions.

- Sets its driver high and falls into synchronization frame start delay if programmed
- Sets its driver high and begins firing its frame sequence.

Synchronization frame start delay

Synchronization frame start delay programs how long the Reader waits after Reader-to-Reader sync has occurred. Its internal driver is set to a high state before firing the next frame and/or frame sequence.

Sync recovery time

Sync recovery time is a programmable variable that indicates how long the reader searches/waits for synchronization on the reader network before firing its multi-protocol tag acquisition sequence. It is recommended that this value be programmed at least 125% of the total multi-protocol tag acquisition sequence.

If the reader detects that the sync bus is driven high prior to the expiry of this time, the reader exits recovery mode, sets its driver high and begins firing its multi-protocol tag acquisition sequence.

Sync recovery attempt limit:

Sync recovery attempt limit is used to indicate how many Sync Recovery Time periods must expire before the Reader no longer searches/waits for synchronization before firing its tag acquisition sequence independent of the reader network. A loss of reader synchronization message will be transmitted via the lane controller interface.

If this limit is programmed with a zero (0) value, the Reader will always wait for Sync Recovery Time to expire before firing its sequence.

Sync-on-skipped-sync frame

Sync-on-skipped-sync frame is used when more than 3 protocols are selected in the multi-protocol tag acquisition sequence. A two sequences-skip is used to indicate where the sequence starts.

How Reader synchronization operates at the toll location

After interrogating all of the assigned MRFM-S (Plus) slots in the rack, each Reader will provide a 'sync ready' signal on its SPM terminal block. Only when reader sync configuration is enabled does synchronization occur.

As busy Readers become ready they will not send any more RF trigger signals until the sync bus indicates that all Readers are ready. Once the last Reader in the network generates its ready signal, all Readers on the sync bus simultaneously generate OBU trigger pulses starting with the RF module in slot 1. This can be seen in the truth table shown below for synchronization circuit consisting of two Readers.

Table 4-1: Boolean Logic Truth Table for Synchronization of two Readers

Reader 1 sync port Tx	Reader 2 sync port Tx	Reader 1 or 2 sync port Rx
0 (<i>ready</i>)	0 (<i>ready</i>)	0 (<i>ready</i>)
0 (<i>ready</i>)	1 (<i>busy</i>)	1 (<i>busy</i>)
1 (<i>busy</i>)	0 (<i>ready</i>)	1 (<i>busy</i>)
1 (<i>busy</i>)	1 (<i>busy</i>)	1 (<i>busy</i>)

The truth table above demonstrates the following rule of synchronization operation:

- The sync bus will only be in the ready state when all Readers in the group are in the ready state.

The last Reader to acquire a ready state controls the system synchronization. Most of the time (greater than 95%), the sync bus will be in the busy state. If operating correctly, the sync bus will normally be in the ready state for about 100 µsec.

Transaction Buffering

Transactions from OBUs, are processed by the CTM. When a Reader CTM loses communications with a Lane Controller (LC), the Reader buffers OBU transactions and error messages (up to a combined total of 1,000,000) in non-volatile memory (i.e., buffered messages will not be lost during power interruptions or Reader resets). When the memory is full, new transactions overwrite the oldest buffered transactions. The memory available for buffering is shared by all RF channels.

When the communication link between an LC and the Reader is re-established, the Reader begins to upload the buffered transactions to the LC. The Reader will pause uploading buffered transactions to the LC to report any new transactions as they occur. Buffered transaction reporting resumes after the new transactions have been reported. Messages from the LC will continue to be acknowledged and acted upon during the upload process.

Buffering and Dual Ethernet LC Destination

When the reader is configured with Dual Ethernet LC Destination (which sends a given tag reports to 2 different LC endpoints), there is now a choice as to how buffering operations.



The new setting **Dual-Destination Buffering Mode** controls how Dual-Destination message buffering is to be performed. Select 'Standard (Legacy)' mode to have buffering start when **both** Ethernet and Dual-Ethernet links are down, buffered messages are drained when both Ethernet and Dual-Ethernet links are resumed. Set to 'Fully Independent' to have **fully independent** buffering between the Ethernet and Dual-Ethernet links when link failures occur.

Log files

The readers generates a number of logs files during its operation. Log files can be viewed from the Log page of the web interface.

Once space is filled on the respective memory partition, the oldest file from the same file type is deleted to create memory space for the new data.

A listing of the main log file types appears below. Other log files that may be present are for Kapsch TrafficCom use.

Table 4-2: List of Log Files Types

Log File Type	Description
tagtxns_YYYY-MM-DD	Daily Tag Transaction log. Summary of individual OBU passages.
event_YYYY-MM-DD	Daily Event log. Contains a periodic report of reader health and transaction count totals.
trouble_YYYY-MM-DD	Trouble Log. Lists any unusual system anomaly (e.g. switchover).



CAUTION:

Log file formats are not under ICD control and the format may change without prior notification. Log files are for diagnostic purposes only and are not guaranteed to be maintained in non-volatile storage.

Tag Transaction Logs

The reader generates an entry for each transaction in a daily tag transaction log. A sample transaction summary for a TDM OBU passage:

```
2020-10-22T23:05:15.121582+00:00 sitename-pri IAG__: VOTE> Ch:4 St:Pgm Txn:00002 Ag:0000
Sn:00000403 Pr:TDM AHs:06 THs:19 >LC
2020-10-22T23:05:15.121838+00:00 sitename-pri IAG__: 4-06
```

Note that a single vehicle passage can generate multiple reports. Which reports are generated depend on the **LC Reporting** settings configured on the Lane Controller page. The report types and the fields they contain described in Table 4-3.

Table 4-3: List of Fields in a Transaction Log Report

Field	Description
IREAD	Optional initial read report when transponder first enters capture zone. Informational report
VOTE	Transaction report at voting time
POST	Optional post-capture zone report if lane assignment or programming status has changed. Informational report
Ch	Channel number. Indicates the assigned channel (1-8). Channel 1 corresponds to the leftmost RF module in the RF rack.
St	Transaction status. Pgm indicates successful transponder programming. PU indicates transponder programming status is Unknown (tag left zone before verify could complete). PF indicates transponder was not programmed successfully. Read indicates the Reader is in read only mode. CrossR indicates an informational report (an adjacent reader reported the passage).
Txn	Transaction number. Note that transaction numbers may appear to skip when using 2 or more Readers with Ethernet connection between them.
Ag	Agency ID of transponder.
Sn	Serial number of transponder.
AHs	"Assigned Handshake count" The number of handshakes (Reads) that occurred on the assigned channel up to voting time. (note RPVs currently count as 1)
THs	For a TDM Transaction: The total number of handshakes (Reads) that occurred on the assigned channel for the previous TDM transaction on the same RF channel. (Note RPVs currently count as 1). A value of 00 is reported after reset or power-up. A value greater than 99 is indicated as 99. For a Non-TDM Transaction: The total number of handshakes (Reads) that occurred on the assigned channel for the previous non-TDM transaction on the same RF channel. A value of 00 is reported after reset or power-up. A value greater than 99 is indicated as 99.
GUARD	Shown for a transaction assigned to a RF channel set to Guard. These transactions will always show !LC to indicate that no report for the LC is generated. Tag programming is disabled for Guard channels.
?LA	In a POST report, indicates that a lane assignment change was detected between the voting time report and the post time report. May be an indication that voting time is not optimal.
?PS	In a POST report, indicates that a programming status change was detected between the voting time report and the post time report.

>LC	>LC indicates transaction is to be reported to lane controller (connection present or not). Only appears on the Active CTM
!LC	!LC indicates transaction is suppressed (e.g. GUARD lane or CrossR transactions or CTM is Inactive).
Cx-HS	HS tag handshakes seen up to voting/post time on the MasterSet center Reader. Note: Does not appear unless inter-reader communication is configured.
Lx-HS	HS tag handshakes seen up to voting/post time on the MasterSet left Reader. Note: Does not appear unless inter-reader communication is configured.
Rx-HS	HS tag handshakes seen up to voting/post time on the MasterSet right Reader. Note: Does not appear unless inter-reader communication is configured.

Event Logs

The reader generates periodic entries into a daily event log file whenever the reader is operational. A sample periodic entry, showing reader CPU and memory condition:

```
reader1-pri STAT_ : {stat      |6307| 444} CPU load: 10% RAM avail: 82%
reader1-pri STAT_ : {stat      |6307| 444} CPU load: 10% RAM avail: 82%
```

The reader also generates a periodic tag transaction summary into the event log. A portion of this entry would appear similar to the following:

Channel	Prot	Status	Txns	AvgHS	Voting	Latency	Speed
3	TDM	PGM	616	20.1	100	100	0

The interesting fields are typically **Txns** (the count of OBU passages) and **AvgHS** (the average total handshake for all transactions of the specified protocol in the specified channel for the reporting interval).

Note that external events (for example power cycling a lane controller attached to a reader) can generate event log entries, and the presence of such entries does not necessarily indicate a reader issue.

The following lists some of the possible sources of messages found in the event log.

- Changes to the reader configuration (made by an operator or a lane controller)
- Periodic OBU transaction count statistics.
- Periodic Reader CPU and Memory monitoring status.
- Reader status changes, such as PSM status, etc.
- Lane controller connection outages (serial or Ethernet).
- Inter-Reader connection outages.

Trouble Logs

Unusual faults or error conditions are reported into a daily trouble log file. On the reader web interface, examine the **Log** page under the "Trouble logs" section for a list of trouble log files. A daily trouble log file is only present for a day in which there was something to report.

During service, the technician should first look for any trouble logs and review their content.

The following lists some of the possible sources of messages found in the trouble log:

- A reader startup message indicates a possible power interruption.
- A missing backplane CFM module.
- An RF module has stopped working or has been removed.
- CGC Health failure
- Switch-over to Secondary (if enabled for LC or Inter-reader fault conditions)

5. INSTALLATION

Introduction

The Reader is shipped with the required power, communications, and logic modules. The Lane Kits are supplied separate from the Reader.

An antenna, an MRFM-S (Plus), a feedline cable adapter, and a circulator (with MRFM-S only) comprise a Lane Kit.

After the equipment is installed, the Reader must be configured via the CTM browser interface. After configuration is complete, the Reader configuration needs saving (see Saving the Reader configuration, page 215) for future reference.

The toll agency and/or system integrator must select the configuration and setup that is suitable for the application and the desired system performance.

CAUTION:



Improper modification of configuration parameters may adversely affect system operation. The default values may not be appropriate for the specific application. It is the system integrator's responsibility to tailor the configuration parameters to the specific operating environment.

CAUTION: Redundant Reader



Please be aware of how Configuration Alignment automatically copies Primary side settings to the Secondary CTM. Refer to Configuration Alignment, page 71.

The earth ground system

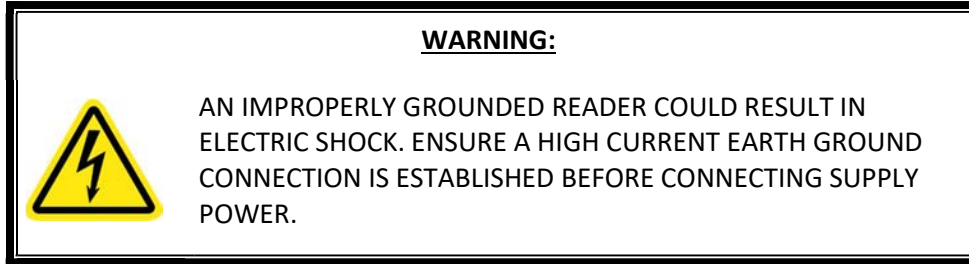

The system integrator supplies the earth ground system for the Reader mains power as per the IEEE 142-2007 standard, particularly; *chapter 5: Sensitive Electronic Equipment Grounding*; and *chapter 3* pertaining to lightning protection; and all other chapter sections describing bonding applications.

The system integrator is responsible for ensuring that grounding and power conforms to local regulatory and safety requirements. The recommendations herein are those ensuring bad grounding does not degrade the reader performance.

In accordance with IEEE 142-2007 all of the following building/site elements (if available) must be bonded together:

- Metal frame of the building (if effectively grounded)
- Metal underground water pipe
- Ground ring, concrete encased electrode

The Reader ground bar (supplied by the system integrator) is bonded to the above-mentioned elements. If none of these elements are available on site, only then a grounding electrode is installed as per NEC to which the Reader ground bar is bonded. The Reader components ground wires are then connected to the ground bar clamps as shown in Figure 5-1.

Lightning arrestors should be installed on the interfaces where lightning induced surges can occur.

Figure 5-1: Earth Ground System (with recommended lightning protectors shown)

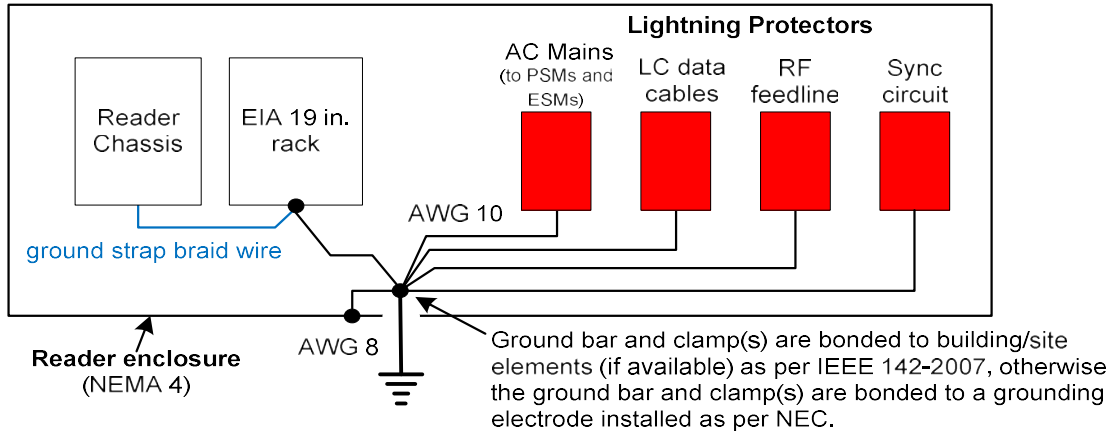

Note: The toll plaza installation may not have a NEMA 4 enclosure. The earth ground system and all other ground connections to Reader components at the toll plaza are identical to those shown in the figure below.

Lightning protectors

Note: It is the system integrator’s responsibility to determine the necessity of installing lightning/surge protection equipment between the data inputs and the earth ground system at the Lane Controller (LC).

Table 5-1: Locations for the Installation of Lightning Protectors

Location required	Schematic Figure number
In-line with antenna RF feed	Figure 5-1: Earth Ground System (with recommended lightning protectors shown), page 156
PSM power	Figure 5-2: AC Mains, page 157
LC Data inputs	Figure 5-3: LC Data Cable installation, page 158
ESM power	Figure 5-11: Synchronization circuit schematic for three Readers, page 169
Synchronization circuit	Figure 5-11: Synchronization circuit schematic for three Readers, page 169

Installing the Reader hardware

Prerequisites: The Reader cabinet is commissioned and the earth ground system has been installed as per IEEE 142-2007, see the earth ground system on page 155.

Install the AC receptacle for the Reader mains power connections within three (3) feet of the front of the Reader.

Note: When handling Reader modules and hardware, always follow accepted Electrostatic Discharge (ESD) practices and standards.

- Using clip nuts, mount the Reader in the EIA 19-inch rack in a NEMA 4 cabinet.

Connect the EIA 19-inch rack ground lug to earth ground:

Connect one end of a braided ground strap to the ground lug on the EIA 19-inch rack.

Neatly position the ground strap along the Reader and apply a light film of tuner lube to the ground lug on the rear of the Reader rack to ensure good grounding contact.

Secure the other end of the braided ground strap to the Reader ground lug.

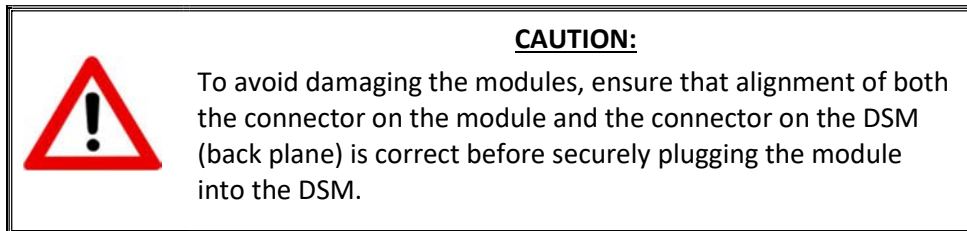

Install the Reader modules in the Reader, ensuring the modules seat properly in their sockets. The installation of the MRFM-S (Plus) is outlined in Installing a Lane Kit on page 159.

Install the power cords for the primary and secondary PSMs. Appropriate lightning/surge protection equipment should be installed between the power mains input and the earth ground system at the Reader, see Figure 5-2 on page 157.

Figure 5-2: AC Mains

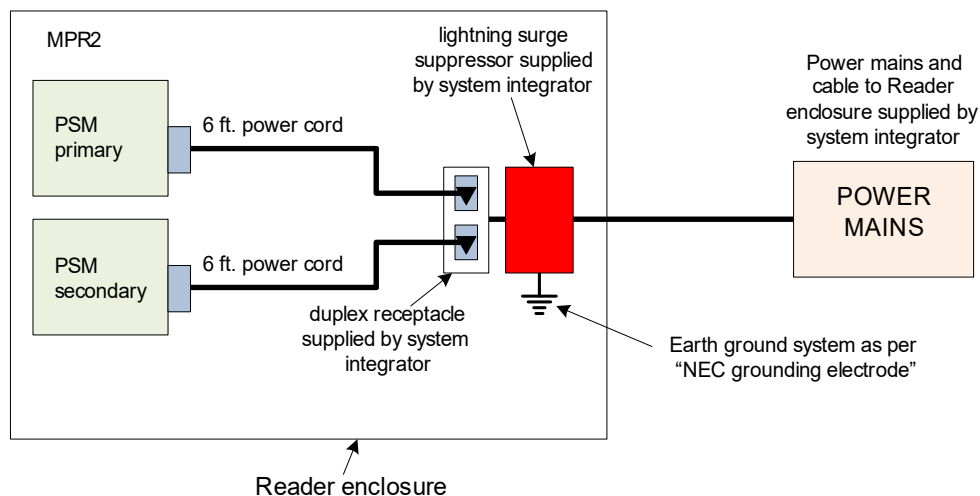

Connect the appropriate cables from the Reader to the LC as shown in Figure 5-3 on page 158.

Figure 5-3: LC Data Cable installation

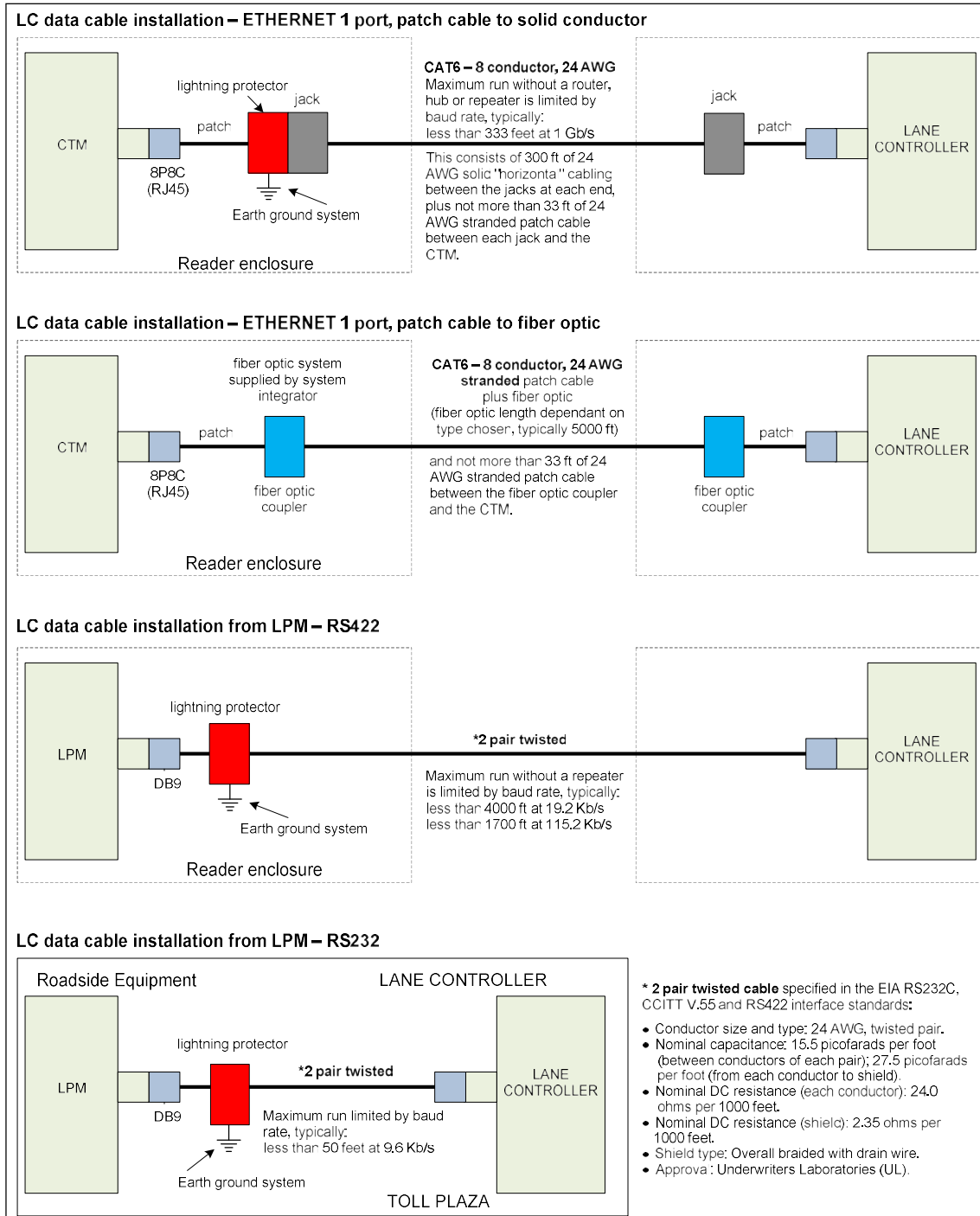

Installing a Lane Kit

Installing an Antenna

1. The antenna mounts on a frame using 2-inch diameter galvanized pipe clamps. For 12 ft wide lanes position the center antenna at lane center of the defined lane. For ORT applications with 12 ft wide lanes, the straddle antenna must be at the midpoint between the left and right antennas. Note straddle min/max measurements in Table 5-2.
2. Orient the weep holes down, such that the radome is facing oncoming traffic.

Using a tilt meter, measure the road pitch and cross lane slope directly under each IAG antenna. Record the results.

Using a tilt meter, align each antenna plate to the tilt angle specified in Table 5-2, in relation to the road pitch measured in step 0 (e.g., If the road pitch is 2 degrees and the desired antenna tilt is 15 degrees, mount the antenna at 17 or 13 degrees depending on the pitch of the road.)

Ensure that the height of the antenna at the center of the radiating face of the antenna as tilted falls within the height range given Table 5-2. Please contact Kapsch Technical Service when considering mounting the antennas outside the specified heights.

Adjust the roll angle of the antenna equal to 0 degrees with respect to the cross lane slope obtained in step 0.

For TDM-only protocol, an ORT antenna installation may be all antennas (IAG 1 or IAG 2 or IAG 3) inline across the roadway as shown in Figure 5-5.

For all passive protocols an ORT antenna installation must be all antennas (IAG 3 only) staggered across the roadway as shown in Figure 5-6.

Table 5-2: Antenna mounting and lane configuration

Antenna	Application	Lane Width	Height	ORT Tilt (off horizontal)	Straddle (min/max c to c)
IAG-3	ORT All Protocols	12 ft. (3.65 m.)	16 - 19 ft. 4.88 - 5.79 m	10 deg.	5.5 ft.(1.68 m)/6.5ft.(1.98 m)
IAG-3	Plaza All Protocols	12 ft. (3.65 m.)	14 - 19 ft. 4.27 – 5.79 m	10 deg.	
IAG-1	ORT or Plaza TDM Only	12 ft. (3.65 m.)	14 - 17 ft. 4.27 - 5.18 m	10 deg.	5.5 ft.(1.68 m)/6.5ft.(1.98 m)
IAG 1	Plaza TDM,6C, SeGo	12 ft. (3.65m)	14 - 17 ft. 4.27 – 5.18 m	10 deg.	
IAG-2	Plaza TDM,6C,SeGo Up to 50 Mph.	12 ft. to 16 feet (3.65m)	9 – 16 ft. 2.74 – 4.88 m	10 deg.	
IAG-2	Plaza TDM Only	12 ft. to 16 feet (3.65m)	9 – 16 ft. 2.74 – 4.88 m	10 deg.	
IAG-2	ORT	12 ft. (3.65m)	16-18 ft 4.27-5.49 m	10 deg.	5.5 ft.(1.68 m)/6.5ft.(1.98 m)

	TDM Only up to 50 Mph				
--	--------------------------	--	--	--	--

Figure 5-4: Generic IAG3 Mounting Dimension Information

This figure shows the general relationship between the mounting pipe and the antennas. The current antenna drawing should be obtained for Kapsch for accurate dimensions.

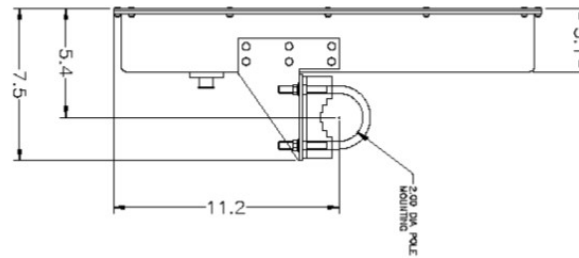

Figure 5-5: Inline ORT Antenna Installation

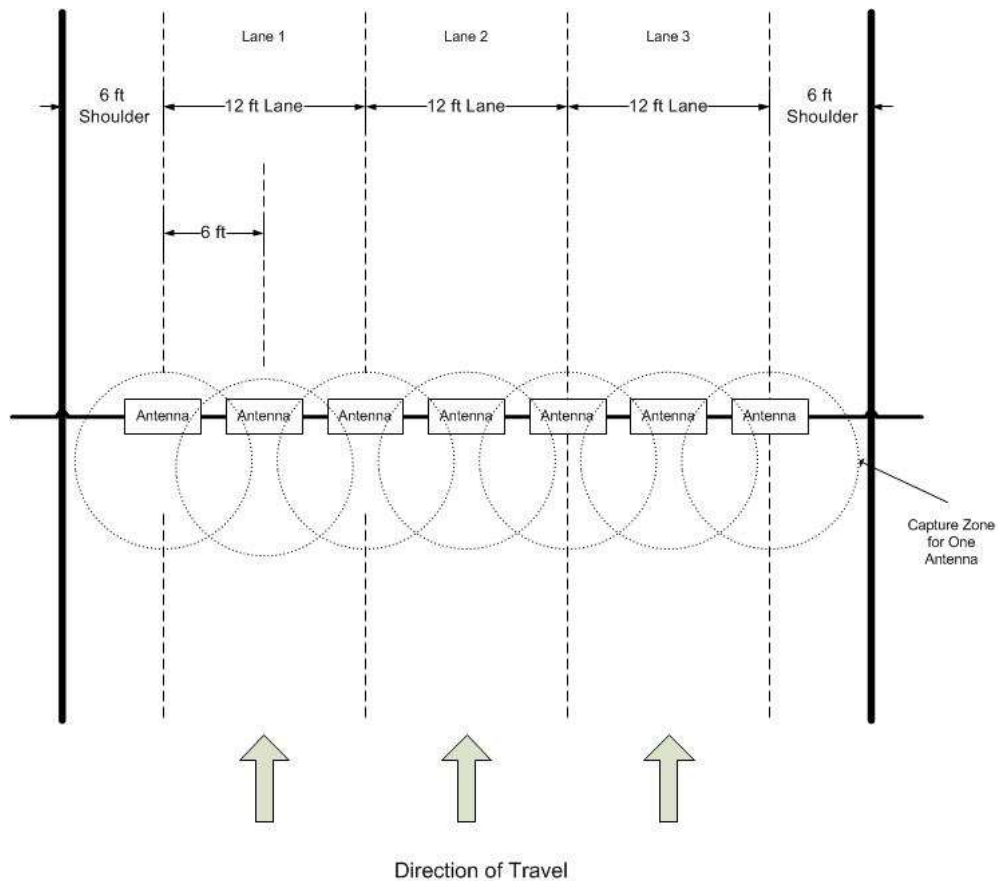
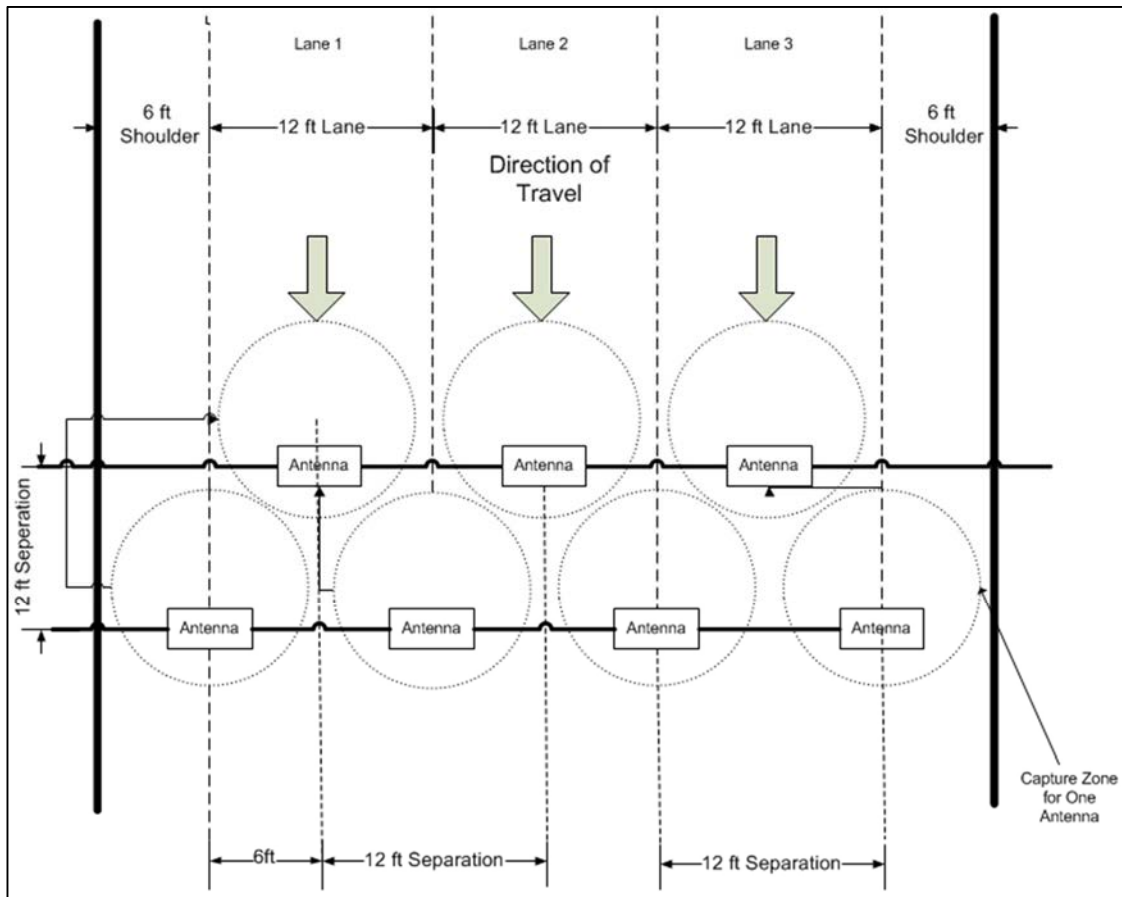

Figure 5-6: Staggered ORT Antenna Installation



The JANUS reader system and antennas in the lane kits are optimized for applications using 12 foot lane widths. The antenna placement requirements and support for this and other lane widths are as follows.

- The lane centerline is the mid-point between the lane markings.
- The antenna bore site should be on the lane centerline and lane markings.
- Physical lane widths below 12 ft. (3.66 m) are not an issue provided the separation between lane centers is 12 ft. or greater.

- If separations are below this there is a higher risk of reports from multiple lanes for the same tag. Note the use of the voting algorithms will correctly assign the tag to the correct lane). There may also be some reduction in the read performance for passive protocols.
- If the physical lane width exceeds 15 ft.(4.57 m), the lane should be treated as a multi-lane free flow configuration and multiple lane kits used per lane. The antenna spacings should be kept at 12 ft separation in each row.
- The same FDM channel frequency should not be used on adjacent lanes, including straddle and shoulder lanes (recommended at least 24 ft. separation between in-line antennas and 21 ft for staggered antennas).
- NOTE: It is preferable to use more frequencies where possible to minimize inter-channel interference due to FDM.
- Two TDM channels that are configured active in the same time slot should not be used on adjacent lanes, including straddle and shoulder (recommended at least 24 feet separation between in-line antennas and 21 ft for staggered antennas).
- NOTE: It is preferable to use the minimum number of TDM slots to minimize the (repeating) time length of the Frame Sequence and maximize handshake count.

Along track alignment

The capture zone created by an antenna is a function of tuning, tilt angle, antenna used, height and reflective properties of the site. There is no single value that can be used to define the alignment of the antenna center to the capture zone. As a guideline nominally 75% of the Capture zone is in front of the antenna center.

Multiple readers

Where multiple readers are on a site, the following additional guidelines apply:

- The readers must be synchronized and running the same Frame Sequence configuration, or compatible Frame Sequence configurations.

Installing the MRFM-S (Plus) modules

Note: MRFM-S (Plus) modules can be replaced while the Reader is powered on and the DSM energized.



CAUTION:

To avoid damaging the modules, ensure that alignment of both the connector on the module and the connector on the DSM (backplane) is correct before securely plugging the module into the DSM.

1. Insert the required number of MRFM-S (Plus) Modules into the Reader and secure in place.

Label the front panel of each MRFM-S (Plus) Module with the corresponding lane number and antenna type.

Installing the RF cables



CAUTION:

Excessive bending or kinking can damage the RF feedline cables. Do not excessively bend or kink the RF feedline cables while fishing them through the rigid conduit from the antenna to the Reader enclosure.

1. Place the RF feedline cable(s) in position. Use an appropriate cable type (coaxial or Heliac) to ensure the RF feedline cable does not produce a signal loss greater than permitted, see Appendix A RF Cable Specification. Use flexible cable (LMR400 preferred) for the short feedline cable between the circulator and the antenna

Using tie wraps, create a service loop of 6 ft. at both ends of the RF feedline cable(s). Trim the excess cable length.

Install spiral wraps on the RF feedline cable(s) where necessary to protect it from abrasion.

Using marker tie wraps and label sets, label the Reader end of each RF feedline (ex. TX Lane 1 or RX Lane 1), each antenna RF feedline (ex. Tx lane 1 or Rx lane 1).

Attach the N-Type male connector to the antenna end of the RF feedline cable(s). Firmly crimp the male connector.

For Bi-Static Operation (MRFM-S only)

1. See Figure 5-7: RF Cable Installation Schematic Bi-Static Operation
2. Using a 10in-lb torque wrench, connect the first RF feedline cable to the Circulator (Port 1). Using self-amalgamating tape, wrap the connection and the circulator to ensure water cannot enter.
3. Using a 10in-lb torque wrench, connect the second RF feedline cable to the Circulator (Port 3). Using self-amalgamating tape, wrap the connection and the circulator to ensure water cannot enter.
4. Using a 10in-lb torque wrench, connect a third (39 inch long) RF feedline cable to the Circulator (Port 2). Using self-amalgamating tape, wrap the connection and the circulator to ensure water cannot enter.
5. Using a 10in-lb torque wrench, connect the other end of the third (39 inch long) RF feedline cable that is connected to Port 2 of the Circulator, to the antenna. Using self-amalgamating tape, wrap the connection to ensure water cannot enter.
6. Attach the N-Type female connector to the reader end of the first RF feedline cable. Firmly crimp the female connector.
7. Using a 10in-lb torque wrench, connect the other end of the first RF Feedline cable that is connected to Port 1 of the Circulator, to the RF Adaptor Cable (800125-001), that will be connected to the "Antenna" Port of the MRFM-S.
8. Attach the N-Type female connector to the reader end of the second RF feedline cable. Firmly crimp the female connector.
9. Using a 10in-lb torque wrench, connect the other end of the second RF Feedline cable that is connected to Port 3 of the Circulator, to the RF Adaptor Cable (800125-001), that will be connected to the "RX" Port of the MRFM-S.
10. Using an SMA wrench, connect each RF Adapter Cable(s) (800125-001) SMA connector to the assigned MRFM-S module port(s).
11. Tie all RF Adapter cables neatly and label both ends of each adapter cable.
12. Secure the service loop portion of the feedline to the antenna-mounting bracket using the tie wraps. Do not severely bend or kink the RF feedline cable.

Note: For a TDM and/or 6C protocol configuration (i.e., no other passive protocols), the Circulator can be located in the cabinet with the reader and one RF feedline cable is connected between port 2 of the Circulator and the antenna. Ports 1 and 3 of the circulator are then connected to the RF modules using the RF Adaptor Cables (800125-001).

Note: The circulators are weather resistant, but should be entirely wrapped in self-amalgamating tape to ensure a water tight seal.

Figure 5-7: RF Cable Installation Schematic Bi-Static Operation

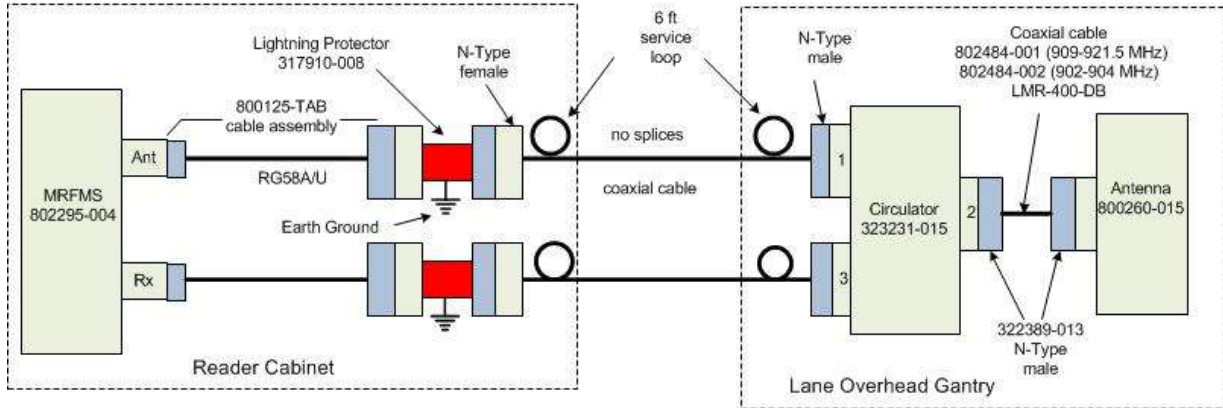
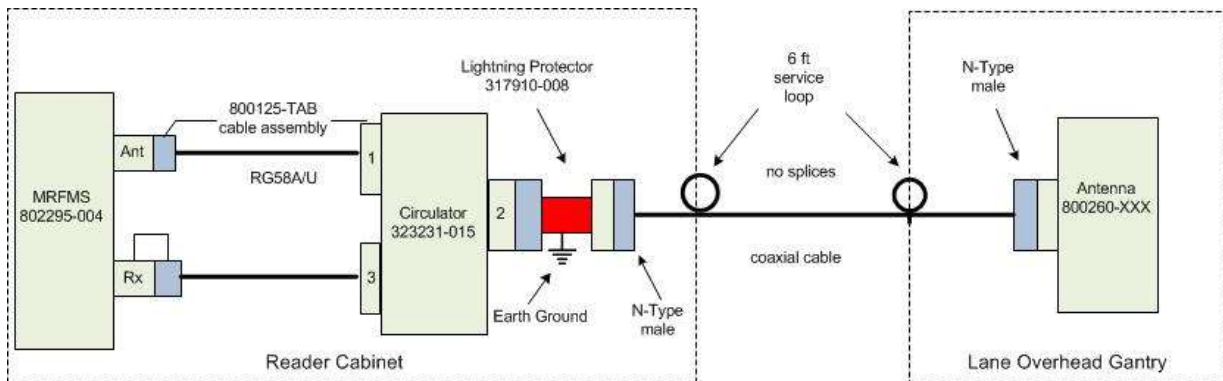

Figure 5-8: RF Cable Installation Schematic Bi-Static TDM Only Operation



Use of the RF amplifier

The maximum cable loss and associated maximum cable length, as defined in the RF Cable Specifications on page 231, is based on the output power of the MRFM-S module and the sensitivity of the transponders. When the site specific application exceeds the limits defined on page 231, an amplifier assembly can be used to

effectively increase the output power of the MRFM-S module an additional 6dB. This 6dB is then used to increase the maximum cable loss permitted as defined on Page 231.

Use of this amplifier should be reviewed with Kapsch personnel before implementation. Figure 5-9 shows a typical installation that includes the use of the power amplifiers.

Figure 5-9: RF Cable Installation Schematic Bi-Static Operation with RF Amplifier

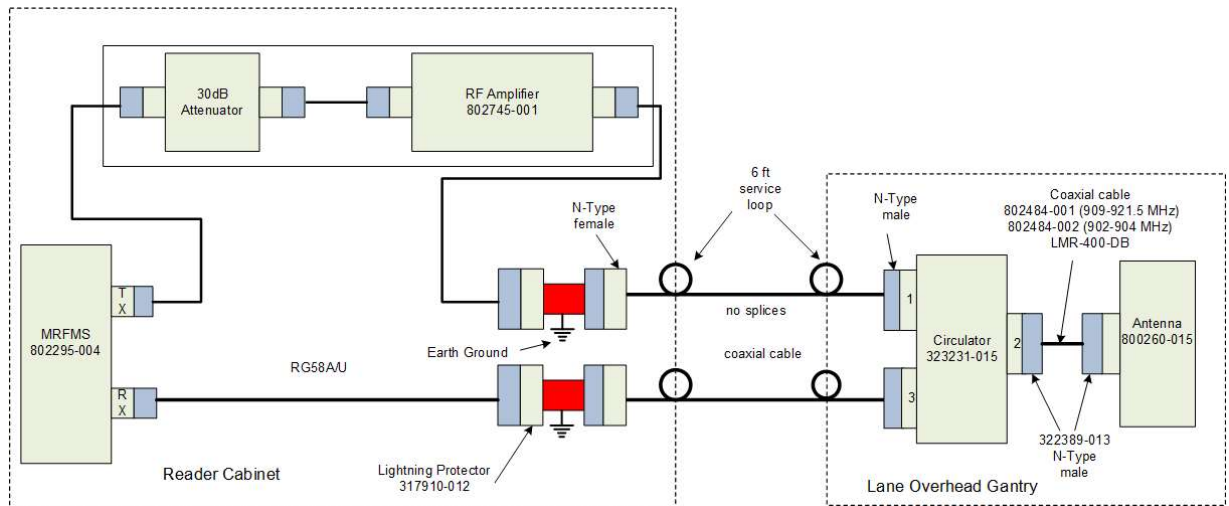

For Mono-Static Operation (MRFM-S Plus only)

1. See Figure 5-10: RF Cable Installation Schematic Mono-Static Operation (MRFM-S Plus only)
2. Using a 10in-lb torque wrench, connect the one end of the RF feedline cable to the antenna. Using self-amalgamating tape, wrap the connection at the antenna to ensure water cannot enter.
3. Using a 10in-lb torque wrench, connect the other end of the RF Feedline cable that is connected to the antenna, to the RF Adaptor Cable (800125-001), that will be connected to the MRFM-S Plus antenna port.
4. Using an SMA wrench, connect the RF Adapter Cable(s) (800125-001) SMA connector to the MRFM-S Plus antenna port.
5. Tie all RF Adapter cables neatly and label both ends of each adapter cable.
6. Secure the service loop portion of the feedline to the antenna-mounting bracket using the tie wraps. Do not severely bend or kink the RF feedline cable.

Figure 5-10: RF Cable Installation Schematic Mono-Static Operation (MRFM-S Plus only)

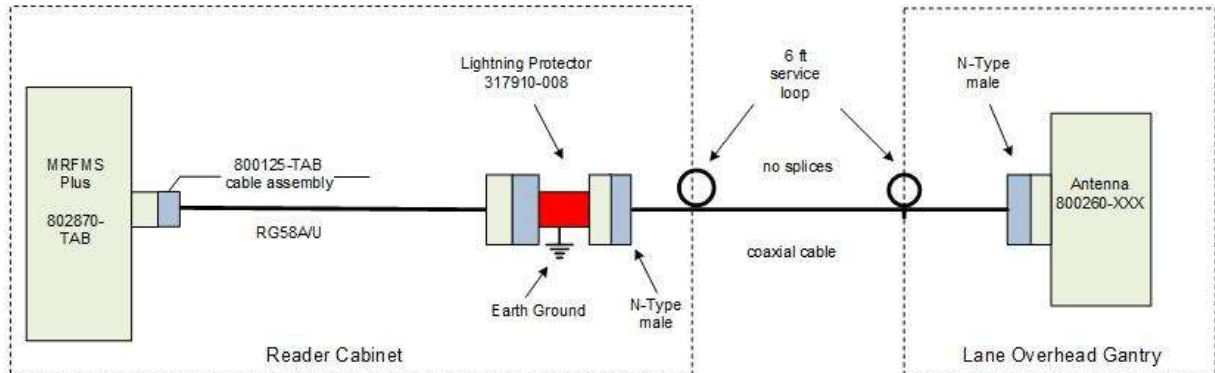

Performing Lane Tuning

Lane Tuning consists of selecting the frequencies to be used on the channels and setting the attenuation for the channels to control the ERP of each lane. These are configured using the web interface. It is recommended that Kapsch Services perform lane tuning to properly configure a site. If the integrator/operator wishes to perform the lane tuning, the following guidelines apply.

- The same FDM channel frequency should not be used on adjacent lanes, including straddle and shoulder (recommended at least 24ft. separation between antennas for in-line antennas, 21ft (18ft lateral) between antennas for staggered antennas before frequencies can be re-used).
- Two TDM channels that are configured active in the same time slot should not be used on adjacent lanes, including straddle and shoulder (recommended at least 24 feet separation between antennas, 21ft (18ft lateral) between antennas for staggered antennas between active antennas).
- The TX attenuation should be adjusted to obtain capture zones nominally 8 to 12 ft. (1.83 to 2.44 m.) along direction of vehicle traffic.

ATTENTION: When installing or replacing a MRFM-S (Plus), RF cables, circulator, or antenna, the lane must be re-tuned.

The Synchronization circuit

Synchronization is required between readers located within reader-reader interference range, or which have overlapping or near-adjacent capture zones, or which may have RF signal reflections (interference) due to any one or combination of varying vehicle sizes, varying traffic patterns or fixed site terrain features. The sync feature eliminates interference between the readers that might otherwise reduce system performance. The synchronization circuit connects SPMs together in a star network. The CTM does the synchronization of the RF module interrogation.

Prerequisites: Sync hub terminal block mounted in a location central to the Readers.

Note 1: The exact location of this terminal block should be marked on a site map to aid system maintenance.

- Readers arranged so that no Reader is farther than 1500 ft. (457.2 m.) from the sync hub terminal block
- Readers arranged so that the total synchronization network cable length is no greater than 2000 ft. (609.6m.).
- No more than six (6) Readers in the synchronization circuit

Note 2: It is recommended that each synchronization cable have two or more spare conductors to support future service repair calls.

Installing a synchronization circuit

1. Connect the Readers to the Sync hub terminal block as in Figure 5-11 on page 169.

Attention: Ensure that cables do not connect from the GND terminal on the SPM to the Sync hub terminal block, as this can create a ground loop and affect synchronization performance.

Note: Before you continue, you will need to gain access to the reader web interface through a service laptop. Refer to Accessing the Reader web interface, page 43.

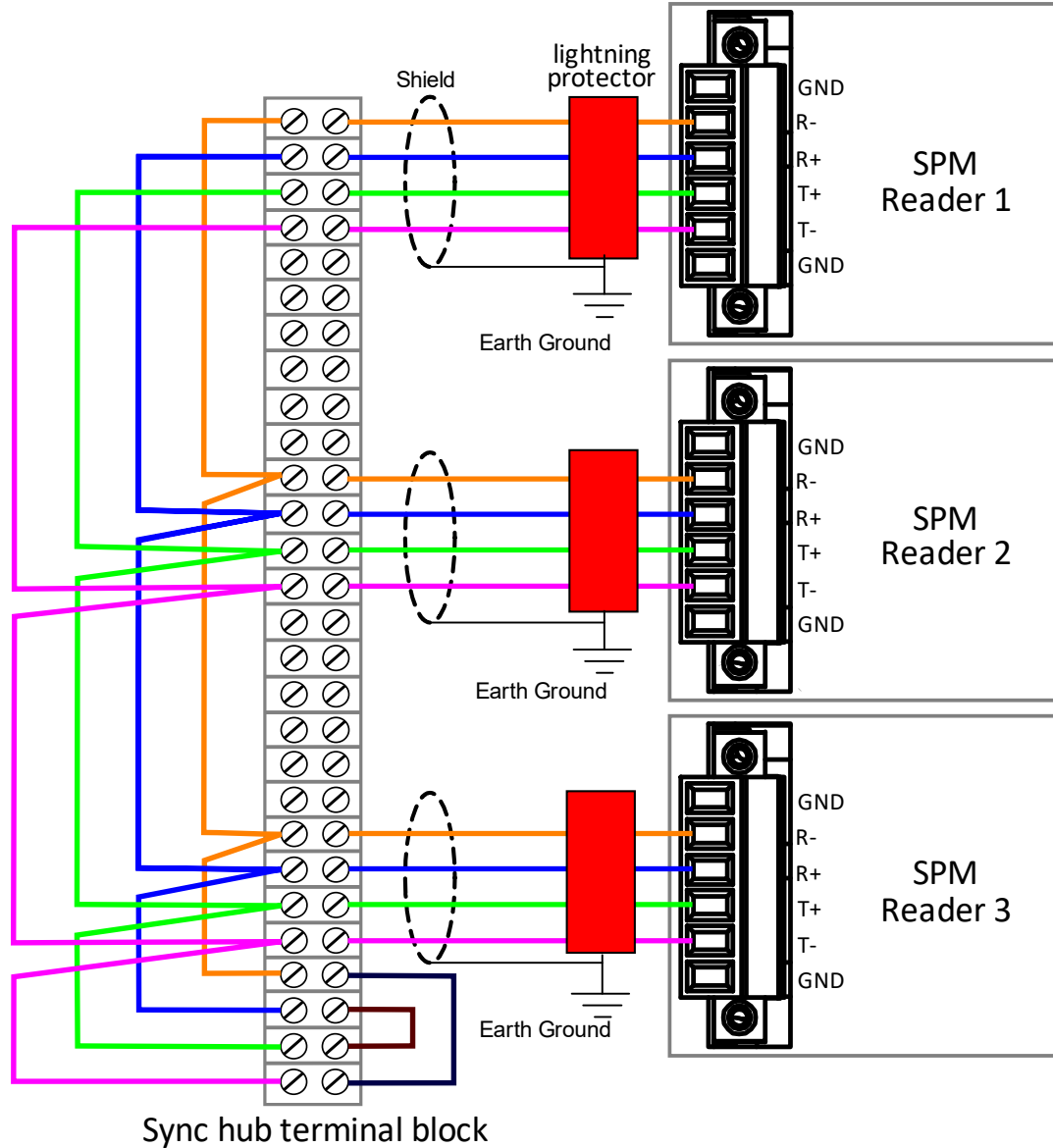

Figure 5-11: Synchronization circuit schematic for three Readers



Note: Up to six (6) Readers can be added to a synchronization circuit.

Synchronization between MPR 2.4 Readers

All Readers in a synchronization circuit must be configured correctly for synchronization to work.

To enable reader sync, via the reader web interface, navigate to the **Tag Protocols** page, click on the + icon, and add a  sync element. To disable reader sync, select the sync element, and click the  icon.

Refer to Reader synchronization, page 69 for a reader sync configuration example.

The Ethernet Network

These are general instructions for using Ethernet Switch Modules (ESMs) to create an Inter-Reader (IR) Ethernet network or a Lane Controller (LC) Ethernet network.

Installing an Ethernet network

Prerequisites: ESMs mounted according to the manufacturer's instructions.

1. Use CAT 6 Ethernet cables to connect the components in the Ethernet network together as shown in the examples in Figure 5-11. Consult the ESM manufacturer's instructions for more details.

Figure 5-12: Schematic of a three-Reader IR network

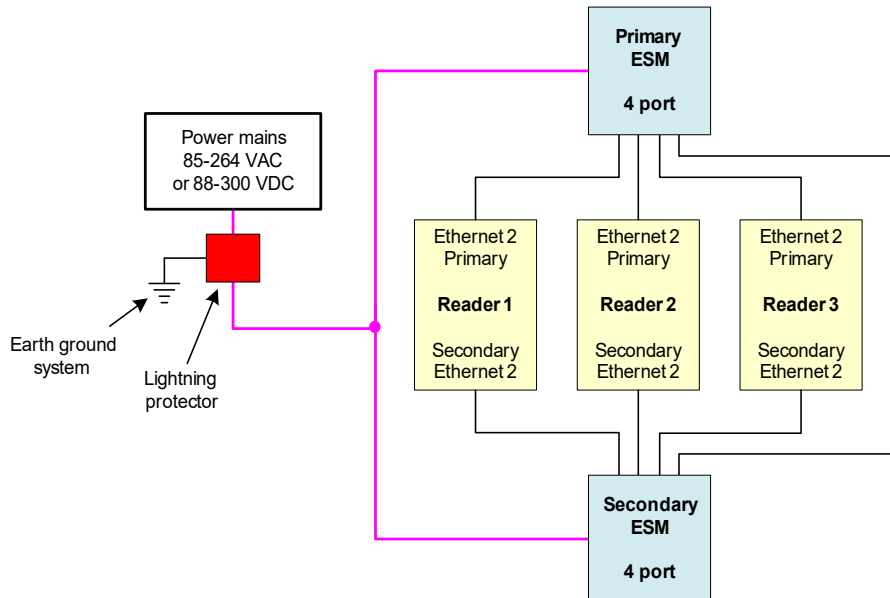
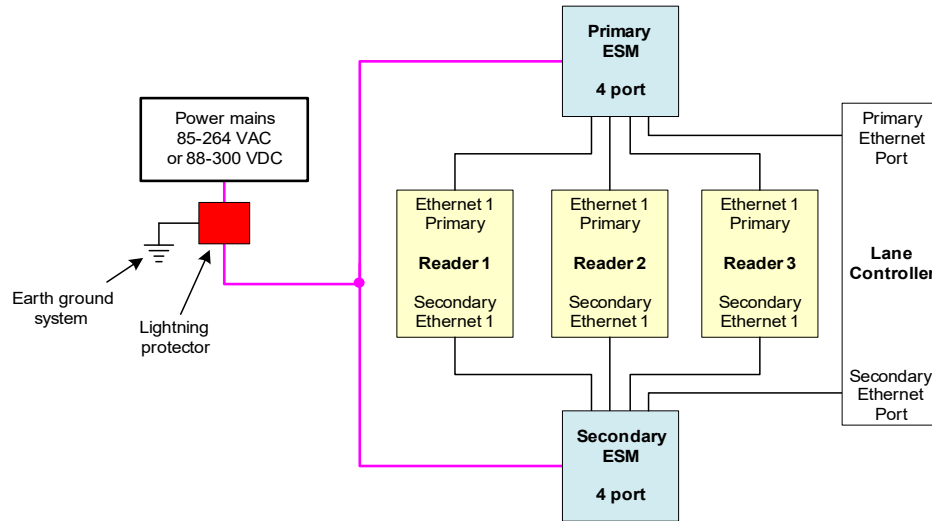

Figure 5-13 Schematic of a three-Reader LC network



Reader connections to the LC via the LPM serial ports

Tag reads can be sent over the reader's serial port connections. Typically, each antenna is associated with a different serial port.

Prerequisites: Accessing the Reader web interface, page 43.

1. Determine what baud rate is required by the lane controller (if using serial connections).
2. From the Dashboard page, in the Configure panel, click on Lane Control.

Result: The following screen appears.

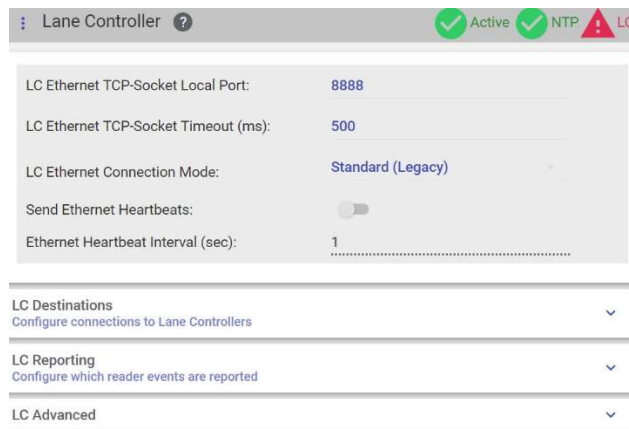

3. On the LC Destinations panel, set the Advanced switch to the ON position. This will open up options for enabling serial port connections on a per antenna (channel) basis.

- In the Destination row, select the Serial check box for each RF channel that will communicate with the LC via an LPM COM Port.

Example: The following screen shows an example of the assignments.

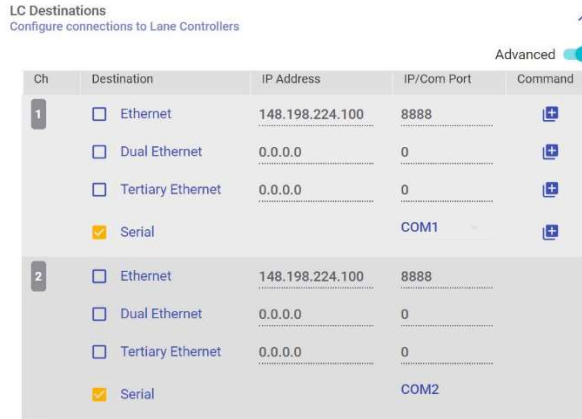

- From the COM N dropdowns, select an LPM port for each RF channel to use to communicate with the LC.

Note 1: By default, RF Channel 1 communicates with the LC via LPM COM 1, RF Channel 2 communicates with the LC via LPM COM 2 and so on, up to RF Channel 8. Do not enable both serial and Ethernet LC.

Note 2: More than one RF Channel can communicate via one LPM COM port, if necessary.

- Click on the "expand" icon in the LC Serial panel to show serial options including baud rate.
- Ensure all the COM Ports selected in step 6 are enabled by the corresponding Port State switch.
- Select the Baud Rate, Data Bits, Parity, and Stop Bits to match the LC communication settings.

Example: An example of what your screen may look like after selection.

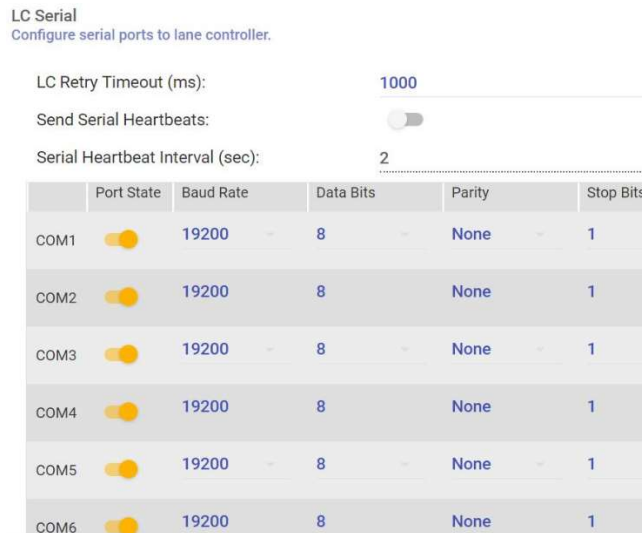

Refer to the Configuring the Reader to switch over automatically when an LC link is down procedure on page 212 to configure the Reader to switch over when the connection from the LPM to the LC is down.

Reader connections to the LC and Inter-Reader via Ethernet

Reader IP addresses

Each Ethernet port in an IR or LC network must have a unique IP address. The IP addresses should be set as required for the site network topology. Default settings are:

- Ethernet 1 port: **192.168.1.50**
- Ethernet 2 port:
- **192.168.0.50** (primary side)
- **192.168.0.51** (secondary side)

Setting the reader IP addresses

Prerequisites: Accessing the Reader web interface, page 43. Do not connect both sides of a reader to a network until each CTM has been given a unique Ethernet 1 IP address.

Note: A secure record of the IP addresses should be maintained to aid network troubleshooting. The primary and secondary Ethernet 1 IP addresses will be required if requesting remote assistance from Kapsch Service.

1. From the reader dashboard, select the **General** page. The network settings are shown in the "Network" panel.



Network	
Reader IP Address:	192.168.1.50
Reader IP Subnet Mask:	255.255.255.0
Default Gateway IP:	0.0.0.0

2. Assign a static IP address and Subnet Mask (netmask) according to your network requirements.
3. If your network design requires it, you can provide a gateway IP address.
4. Repeat above steps for the secondary CTM.

Configuring an LC Ethernet network

The Reader data can also be sent to the LC via an Ethernet network.

Prerequisites: Accessing the Reader web interface, page 43. You must have **Change Configuration** permissions.

1. Select the **LC Destination** panel on the **Lane Controller** page.
2. In the Destination row, select the Ethernet check box for each RF channel that will communicate with the LC via Ethernet.

Result: The following screen appears.

LC Destinations
Configure connections to Lane Controllers

Advanced

Ch	Destination	IP Address	IP/Com Port	Command
1	<input checked="" type="checkbox"/> Ethernet	148.198.224.100	8888	
2	<input checked="" type="checkbox"/> Ethernet	148.198.224.100	8888	
3	<input checked="" type="checkbox"/> Ethernet	148.198.224.100	8888	
4	<input checked="" type="checkbox"/> Ethernet	148.198.224.100	8888	
5	<input checked="" type="checkbox"/> Ethernet	148.198.224.100	8888	

3. Enter the LC IP address and Port number for each RF channel.

4. If all the RF channels will be communicating with the LC at the same IP address, click button.

Result: All RF channels selected to communicate over Ethernet will now have the same destination LC IP.

Note: When setting the LC Retry Timeout, consider the baud rate used to communicate with the LC and the processing speed of the LC to avoid false failure reports.

5. Enter a time, in milliseconds (ms), in the LC Ethernet TCP-Socket Timeout field.

Note: If an LC does not respond within this time, the Reader will consider Ethernet communications to the LC to be down and could trigger a switchover, depending on the redundancy settings.

Configuring the Reader IP Address (Ethernet 1 IP address) via the Diagnostic Port

Attention: Contact Kapsch Service to set the ETHERNET 1 port IP address via the Diagnostic Port if the IP address has been lost or cannot be determined.

Lane Assignment

The reader can perform lane assignment (voting) to identify the most probable lane in which the OBU resides. This is used when producing VOTE or POST messages to the Lane Controller. The settings for voting method and voting communication are defined on the Lane Assignment page, shown below.

1. From the dashboard page, click the **Lane Assignment** button.

Result: The following screen appears.

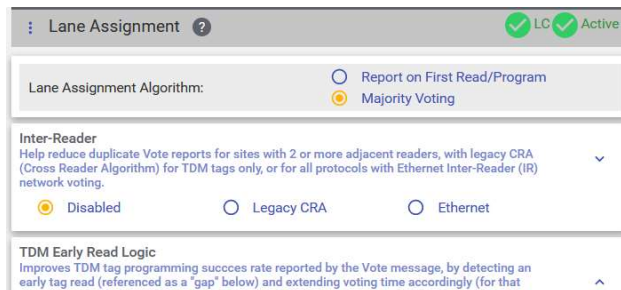

The default lane assignment method is "Majority Voting", which means that the reader generates a VOTE report to the lane controller based on which channel has the highest handshake count at voting time. The voting time is settable on the "Channels" page. The other lane assignment option "Report on First Read/Program" is a legacy mode from a previous generation of the reader. In this mode a report is generated as soon as a tag is seen and programmed. This legacy mode is not recommended for ORT use.

Multiple Reader Lane Assignment

ORT lanes allow OBUs to cross multiple capture zones which may cross between readers. The Readers should assign an OBU to one RF channel to prevent duplicate transactions.

Figure 5-14: Two Readers communicating with one OBU

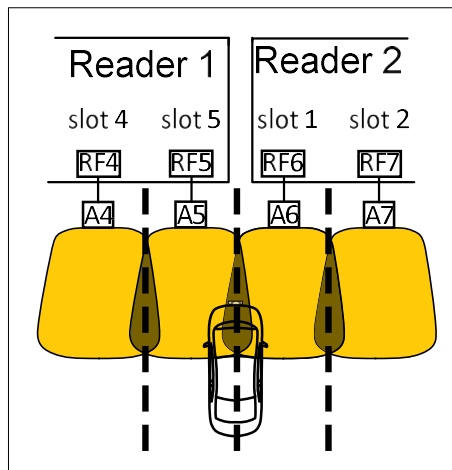

Selecting the correct communication method between reader

The communication method determines how Readers communicate with each other to share information for determining lane assignments. This is important for situations similar to that shown in Figure 5-14, where, to assign the OBU to a lane, Reader 1 and Reader 2 need to share handshaking information. The available communication methods are:

Legacy CRA: there is no physical link between the Readers, such as an IR Network. Instead, the first Reader to contact an OBU, programs the OBU. All other Readers that subsequently contact the OBU recognize it was recently programmed and ignore the OBU.

Note: CRA only applies to the TDM protocol, with read/write enabled.

Note: The TDM Reader ID must be different for all adjacent readers. Shown on Tag Protocols page.

Note: The TDM Plaza ID must be the same for all adjacent readers. Shown on Tag Protocols page.

Note: All adjacent readers must be time synchronized.

Note: The Transponder Timeout, set in the Group panel on the Channels page, must be greater than the time difference between all Reader clocks in the network.

Ethernet: An IR Ethernet network connects the Readers together and handshaking information is shared between Readers. The Readers assign the OBU to one channel and all other transaction reports from other Readers are suppressed.

Note: The same Legacy CRA constraints listed above also apply to Ethernet voting, as this is used as a fallback when a IR link loss is detected.

Note: Multiple (voting) group IDs are not supported across multiple Readers.

Configuring Voting over an Inter-Reader (IR) network

This procedure describes the network settings for Inter-Reader lane assignment.

Prerequisites: Accessing the Reader web interface, page 43.

1. From the **Lane Assignment** page, in the **Inter-Reader** panel, click on the **Ethernet option**
2. Review the **Inter-Reader alias** setting on the Primary CTM. The Inter-Reader alias must be unique for each adjacent reader at a plaza but the same for both Primary and Secondary CTM. Note that with Configuration Alignment enabled, this setting is automatically replicated on the Secondary side. For the first reader you configure at a plaza, you could keep the default alias of 192.168.0.151. The second reader you configure could be set to 192.168.0.152, for example. Note all Inter-Reader addresses must be on a different subnet than the Ethernet 1 interface.
3. Review the **Ethernet 2 IP Address** setting. It must be on the same subnet as the Inter-Reader alias configured above. For the first reader you configure at a plaza you can keep the default Ethernet 2 IP address of 192.168.0.50 on the Primary side. On the Secondary side, you can keep the default Ethernet 2 IP address of 192.168.0.51. Additional readers you configure must have a unique Ethernet 2 IP address setting across all CTMs. For example the next reader you configure could have Ethernet 2 IP address of 192.168.0.52 on the Primary side and 192.168.0.53 on the Secondary side.

Configure how multiple transactions are reported to the LC in IR network:

- To send one transaction report per OBU to the LC without informing the LC of suppressed reports, select **Disabled** from the **Cross-Reader Reporting** box.
- To send all transaction reports (one per reader) for an OBU to the LC, select **Report All** from the **Cross-Reader Reporting** box.
- To send one transaction report per OBU to the LC and also inform the LC of suppressed reports, select **Report Non-zero** from the **Cross-Reader Reporting** box.

Configuring Left and Right Adjacent Readers

For proper Inter-Reader lane assignment across adjacent readers, a reader must be configured with a “Left” neighbor, a “Right neighbor, or both, according to the following definitions.

Left Reader (“low channel neighbor”)

Enable the “Left Reader” setting if a reader’s lowest in use channel is adjacent to another reader’s channels. This is regardless of direction of travel. A channel is considered “in-use” if it is configured as Active or Guard on the Channels configuration page.

Right Reader (“high channel neighbor”)

Enable the “Right Reader” setting if a reader’s highest in-use channel is adjacent to another reader’s channels. This is regardless of direction of travel.

Note: Regardless of the channel firing sequence the physical antenna placement must align with the RF channel order. This means adjacent channels connect to adjacent antennas. This is regardless of the direction of travel. This is the case in the example below.

Note: At the reader seam between two adjacent readers, on lane must be matched to a high channel number (e.g. Channel 5) whereas the adjacent lane from the adjacent reader must be matched to the lowest channel number (e.g. channel 1). This is the case in the example below.

The following example shows how to configure the IR settings based on where the Reader sits in the site.

Example: Reader 1 in Figure 5-15 has a Reader on its right (Reader 2) but no Reader on the left. Reader 2 in Figure 5-15 has a Reader on its right (Reader 3) and a Reader on its left (Reader 1). Reader 3 in Figure 5-15 does not have a Reader on its right but has one on its left (Reader 2).

Figure 5-15: Three readers covering one direction of wide lane ORT traffic

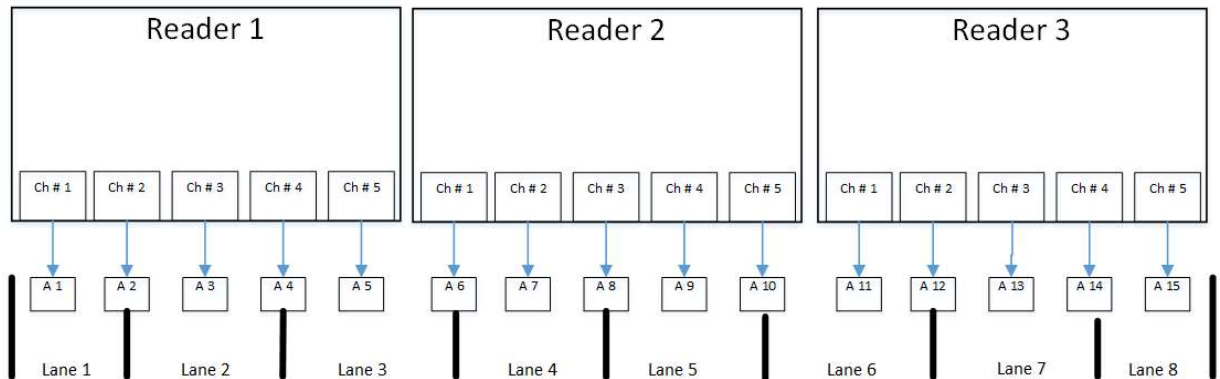

1. Navigate to the Inter-Reader panel on the Lane Assignment page. The Inter-Reader alias and Ethernet 2 IP address have already been configured as discussed in the previous sections.

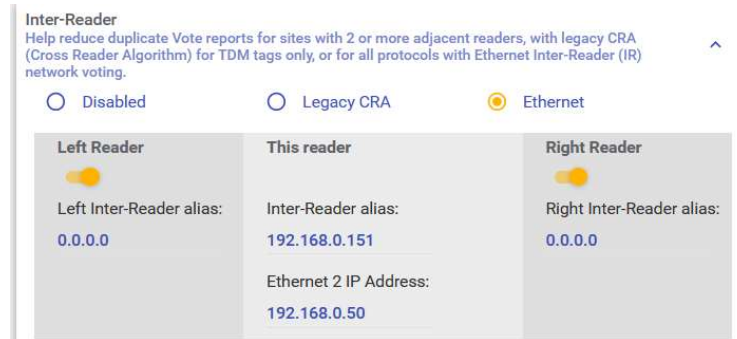

2. If there is a low-channel neighbor, toggle the Left Reader switch. For the example this must be done on both Reader 2 and 3, as these both have a low-channel neighbor.
3. Enter the Left Inter-Reader alias IP address (check the lane assignment page of the neighbor to see its configured alias, overwriting the default 0.0.0.0)
4. If there is a high-channel neighbor, toggle the Right Reader switch. For the example this must be done on both Reader 1 and Reader 2 as these both have a high-channel neighbor.
5. Enter the Right Inter-Reader alias IP address.

Note: For a MPR 2.4, a reader restart or reboot is not required after changing the Inter-Reader settings.

6. To set the Reader to switchover when an IR link is down, To ensure correct operation it is also necessary to:

Configure Protocols **Tag Programming** (see Programming on page 62) ensuring that:

- TMP and TCP are enabled
 - The Plaza IDs of all Readers at the plaza match
 - The Reader ID for each Reader is different. Note to change the reader ID you must enable TDM write and Traffic Management Mode
7. Align the reader time to be the same across all readers. (If you have an NTP server on the local LAN, please enable it. See N, page 218).
 8. On the Channels page, toggle the Advanced slider, and ensure all channels covering one direction of traffic have the same (voting) Group ID (typically all group 0).

Configuring Legacy Cross Reader Algorithm (CRA) communication

Prerequisites: Accessing the Reader web interface, page 43.

1. Navigate to the **Lane Assignment** page.

Select **Legacy CRA** in the Inter-Reader panel.

Review the **Cross-Reader reporting** setting. This specifies if the reader sends the informational CrossR Vote messages to the Lane Controller. A CrossR report means that an adjacent reader has reported the Vote message to a LC. Recommended setting: Disabled

To ensure correct operation it is also necessary to:

Configure TDM Tag Programming (see Programming on page 52) ensuring that:

- TMP and TCP are enabled

- the Plaza IDs of all Readers at the plaza match
- the Reader ID for each Reader is different

On the **Channels** page, toggle the Advanced slider, and ensure all channels covering one direction of traffic have the same (voting) Group ID (Group # 0). Multiple (voting) group IDs are not supported across multiple Readers.

Set the Reader clocks to within 2 seconds of the same time (either Manually setting the Reader time and date procedure on page 219, or via the LC) or use NTP to time synchronize if there is an NTP server on the LAN.

Note: The Transponder Timeout, set on the Channels page, must be greater than the time difference between all Reader clocks in the network.

Selecting the Voting Algorithm

By default the reader uses a Majority Voting algorithm which generates a single passage (a.k.a. Vote) report to the lane controller, a fixed voting time (default 100 ms) from the initial read of a tag, and assigns the tag to the RF channel with the highest handshake count. Another option "Report on First Read/Program" reduces average reporting latency by immediately reporting a tag on the first read (or program, if the protocol supports programming).

Prerequisites: Accessing the Reader web interface, page 43.

1. From the home page, select the **Lane Assignment** page.

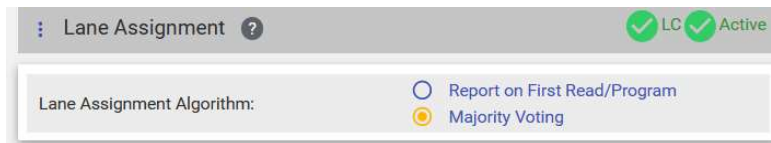

Select the desired **Lane Assignment Algorithm**

Configuring Voting Time

Manually setting a voting time gives a fixed voting time to each channel. Dynamic voting time allows the Reader to calculate and base the voting time on the average capture zone span time (the average time it takes for OBUs to pass through a capture zone, for a given channel).

Manually set the voting time for a channel

Prerequisites: Accessing the Reader web interface, page 43.

1. Navigate to the **Channels** page.

Result: The following screen appears.

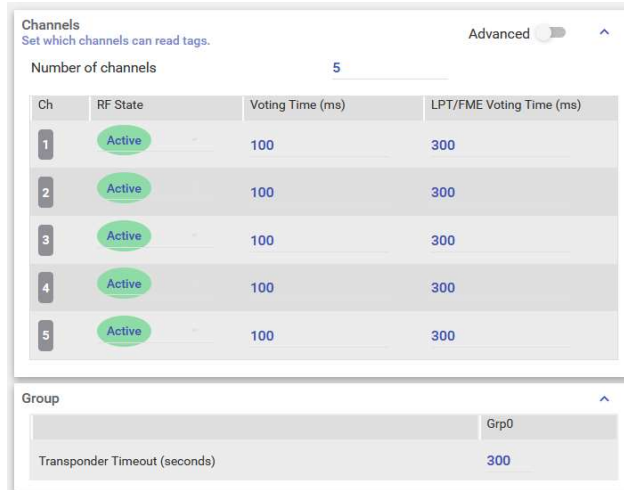

2. In the Voting Time field enter a voting time in milliseconds, to set the voting time for all OBUs that are not TDM bumper mount transponders transponders. Repeat for all channels.
3. In the LPT/FME Voting Time field enter a voting time in milliseconds, to set the voting time for TDM bumper mount transponders (also referred to as LPT or FME). Usually these OBUs are given a longer voting time. Repeat for all channels.
4. Review the Transponder Timeout field in the Group panel. This specifies the minimum time a transponder must be away from the last read in a capture zone before it is reported again as a new transaction when it is detected.

Allowing the Reader to calculate the optimum voting time using Dynamic Voting

Prerequisites: Accessing the Reader web interface, page 43.

1. From the dashboard, select the **Channels** page.
2. Toggle the Advanced slider.

Result: The following screen appears.



For a given channel, in the **Dynamic Voting** column, select **Reader** to allow the Reader to automatically adjust the voting time according to prevailing traffic speeds. Typically all channels would be set to Reader, but that is not required.

Review the **Dynamic Voting Sample Size** field. This is the number of previous transactions the Reader uses in the specified channel to determine a new potential voting time. A new potential voting time is calculated after each OBU passage.

Dynamic Voting ^

Ch	Dynamic Voting	Dynamic Voting Sample Size	Dynamic Voting Threshold (%)	Dynamic Voting Capture Zone Span Multiplier
1	Reader	20	20	2
2	Reader	20	20	2
3	Disabled			
4	Disabled			
5	Disabled			

Review the **Dynamic Voting Threshold %** field. This is the percentage by which the new voting time must change from the current voting time, in order for the reader to switch to it. This is intended to prevent overly frequent adjustments.

Configuring Channel Weight for straddle antennas

The handshake count of straddle channels (channels 2 and 4 in Figure 5-16) typically have less weight assigned to them than non-straddle channels (channels 1, 3, and 5 in Figure 5-16).

Prerequisites: Accessing the Reader web interface, page 43.

1. From the dashboard, select the **Channels** page.
2. Toggle the Advanced slider.
3. Enter a percentage in the Channel Weight field for each channel.

Result: The following screen appears.

Note: A channel weight of 100% means the full handshake count is considered at voting time, while a channel weight of 50% means only half the handshake count is considered at voting time.

Channels
Set which channels can read tags. Advanced

Number of channels

Ch	RF State	Voting Time (ms)	LPT/FME Voting Time (ms)	Channel Weight (%)	Group #	Dynamic Voting
1	Active	100	300	100	0	Disabled
2	Active	100	300	50	0	Disabled
3	Active	100	300	100	0	Disabled
4	Active	100	300	50	0	Disabled
5	Active	100	300	100	0	Disabled

Figure 5-16: Three Wide ORT lanes with two straddle antennas

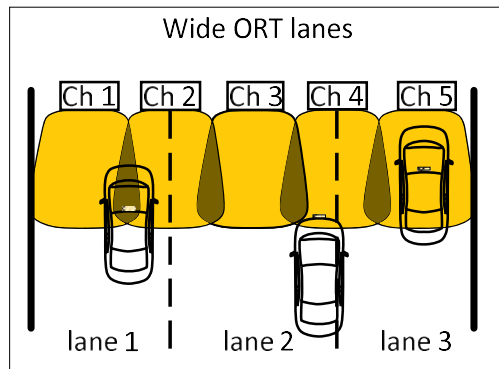

6. TROUBLESHOOTING AND TESTING

Troubleshooting Methodology

Troubleshooting trees are provided for resolving the most common Reader issues. A **Test and Replace** methodology is used for servicing the Reader system. The general steps are:

1. **Test** all symptoms that may have attributed to the reported system fault. Use the following suggestions to reveal faults:
 - Examine the reader Status web page.
 - Examine the trouble log files for any reported issues with the Reader (page 152).
 - Observe the status LEDs on the Reader front panel (see LED Status, page 185).**Replace** a suspected faulty component.
Continue with symptom testing and component replacement until there are no fault symptoms.

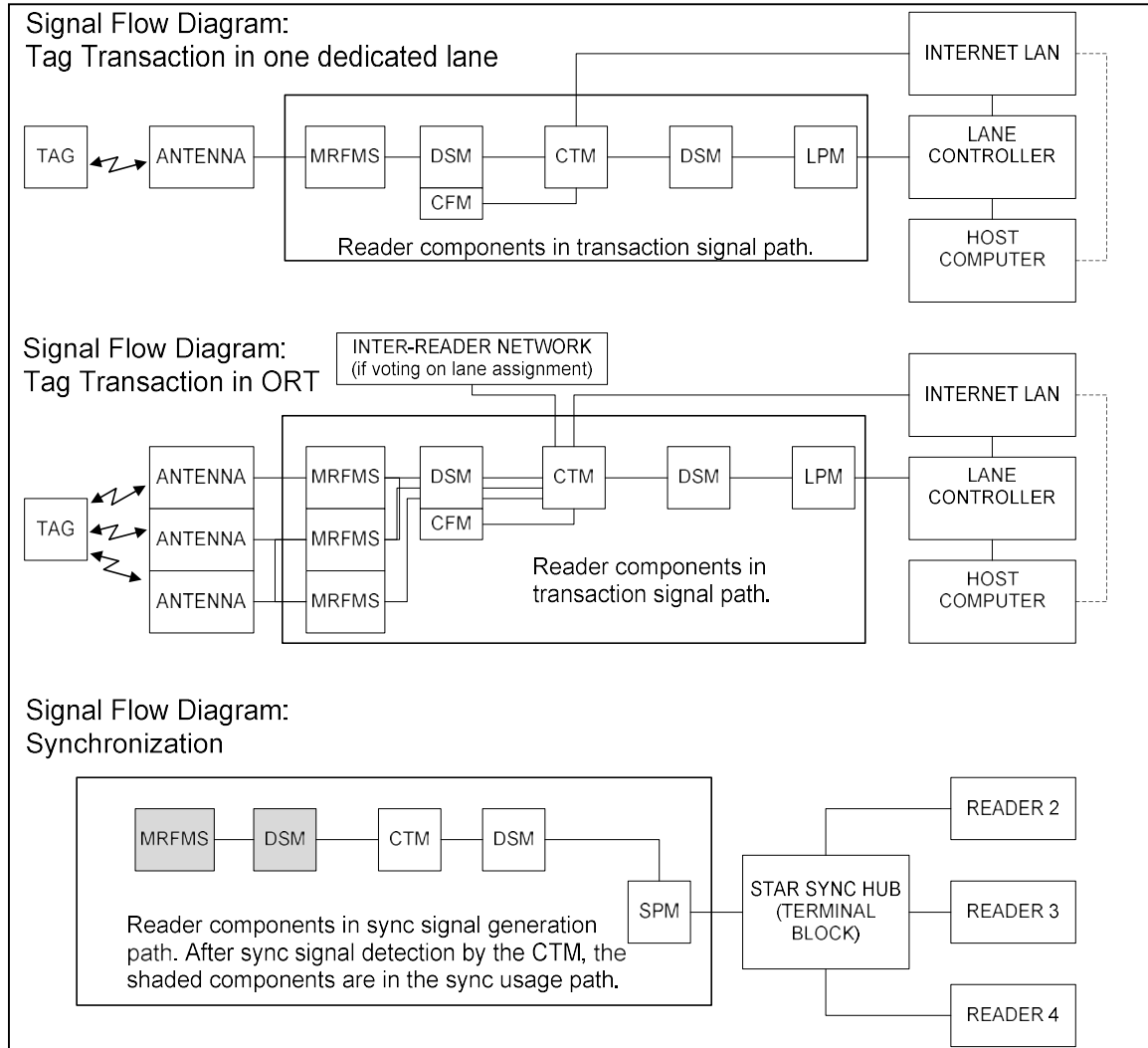

Figure 6-1: Signal Flow Diagrams



LED Statuses

The following table gives an overview of all the LEDs on the Reader. See the Troubleshooting Trees beginning on page 187 to resolve any issues.

Table 6-1: CTM LED states explained

CTM LEDs			
LED	State	Meaning	
CGC	solid green	CGC is functional	
	solid red	CGC has failed	
	solid amber	CGC suspended (i.e., Frame Sequence empty)	
MC	 blinking green	MC is functional	
	 blinking amber	MC is functional, but CPU load is high (above 50%)	
	 blinking red	MC is functional, but CPU load is extreme (above 80%)	
	solid green or solid red	MC has failed	
SYNC	On the 'Active' CTM	solid green	Reader is synchronized with other readers on the sync network.
		flashing red	Reader out of sync with other readers on the sync network, or, No activity detected from other readers on the sync network
		flashing green/amber	Reader is out of sync with other readers on the sync network and attempting recovery
		Off	Synchronization is disabled
	On the 'Inactive' CTM	solid green	The inactive side is in sync with the Active side
		flashing red	The inactive side is out of sync with the Active side, or no activity is detected by the active side on the internal sync line.
		flashing green/amber	The inactive Side is out of Sync with Active side and is attempting recovery.
		off	N/A
ACTIVE	solid green	The CTM is active and in control. This indicates if the primary or secondary side is active.	

CTM LEDs		
LED	State	Meaning
	solid red	The CTM is not active
POWER	solid green	CTM is receiving power from PSM
	off	CTM is not receiving power from PSM, or, CTM reset switch is OFF
ACTIVITY (Ethernet 1)	flashing green	Data is being transmitted via the Ethernet 1 port
	off	Data is not being transmitted via the Ethernet 1 port
ACTIVITY (Ethernet 2)	flashing green	Data is being transmitted via the Ethernet 2 port
	off	Data is not being transmitted via the Ethernet 2 port

Table 6-2: PSM LED states explained

PSM LED		
LED	State	Meaning
+15 STATUS	solid green	PSM is supplying +15VDC via DSM
	off	PSM is not supplying +15VDC
+5 STATUS	solid green	PSM is supplying +5VDC via DSM
	off	PSM is not supplying +5VDC

Table 6-3: MRFM-S (Plus) LED states explained

MRFM-S or MRFM-S Plus LED		
LED	State	Meaning
DATA	solid green	MRFM-S is functional
	off	MRFM-S is not enabled

Troubleshooting tree: LC Ethernet 1 Port communications not working

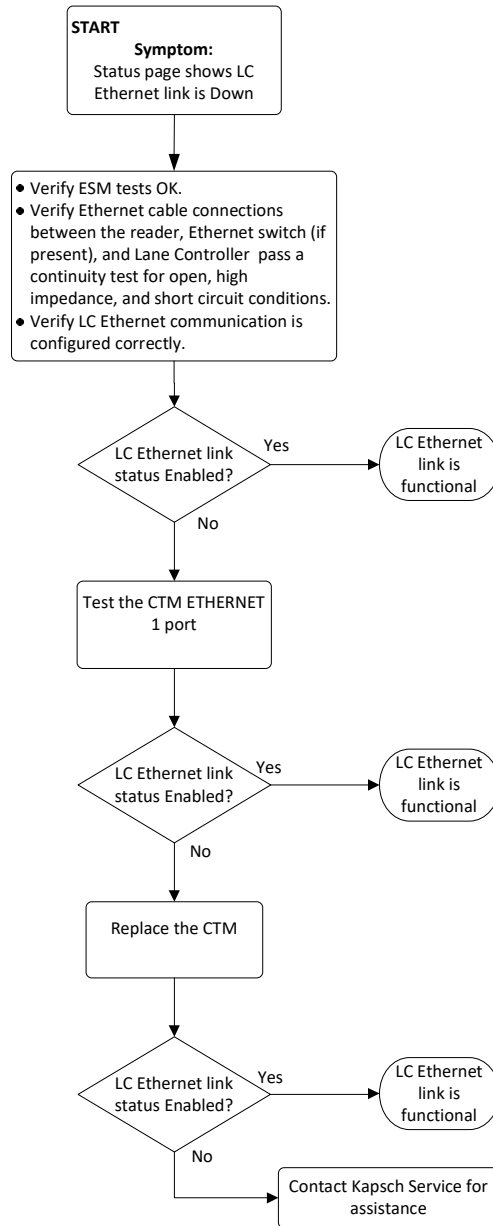

Troubleshooting tree: Ethernet 2 Port communications not working

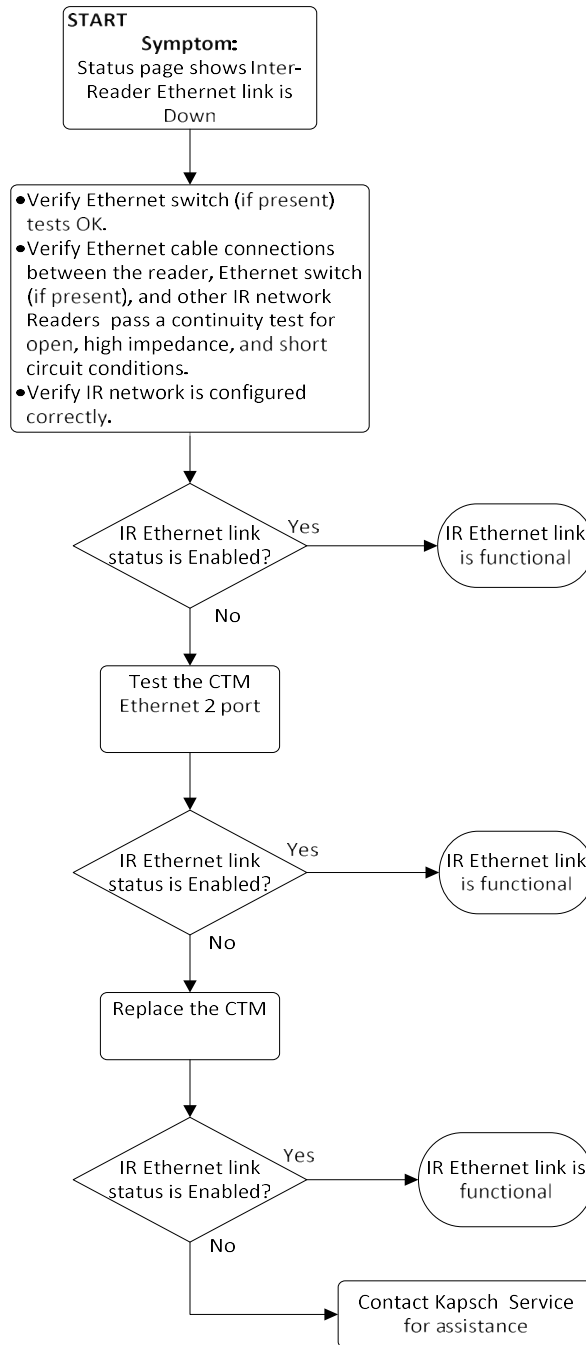

Troubleshooting tree: LPM Serial Port communications not working

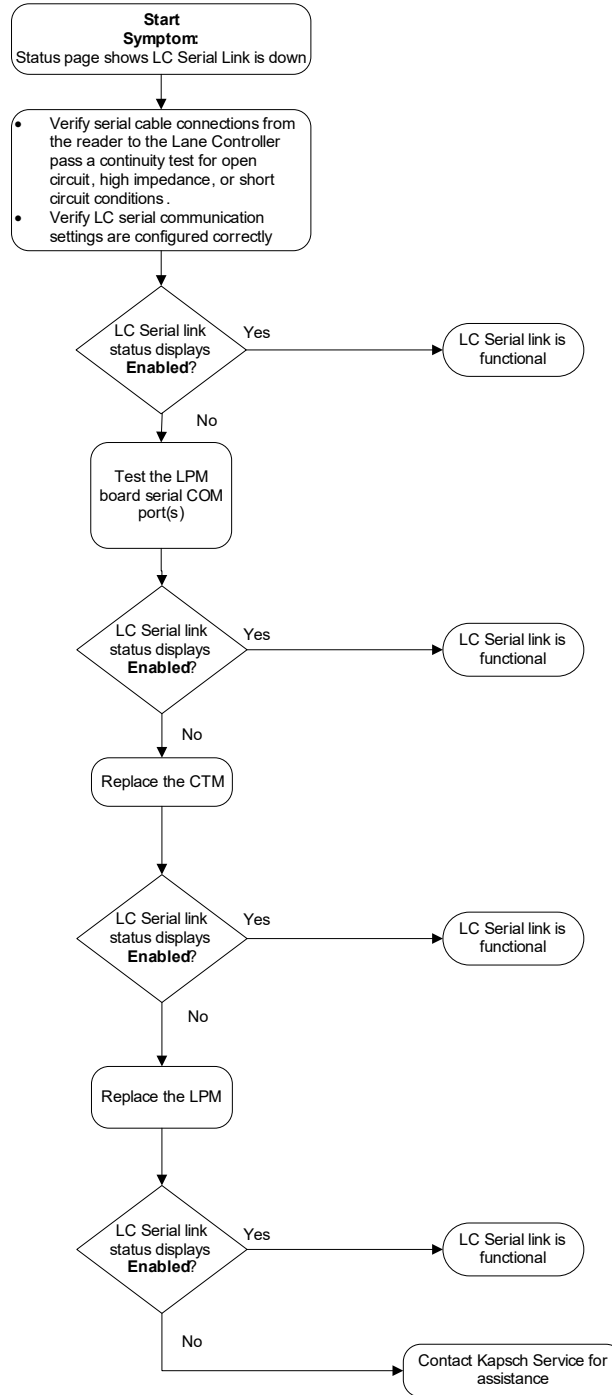

Troubleshooting tree: MRFM-S (Plus) not working

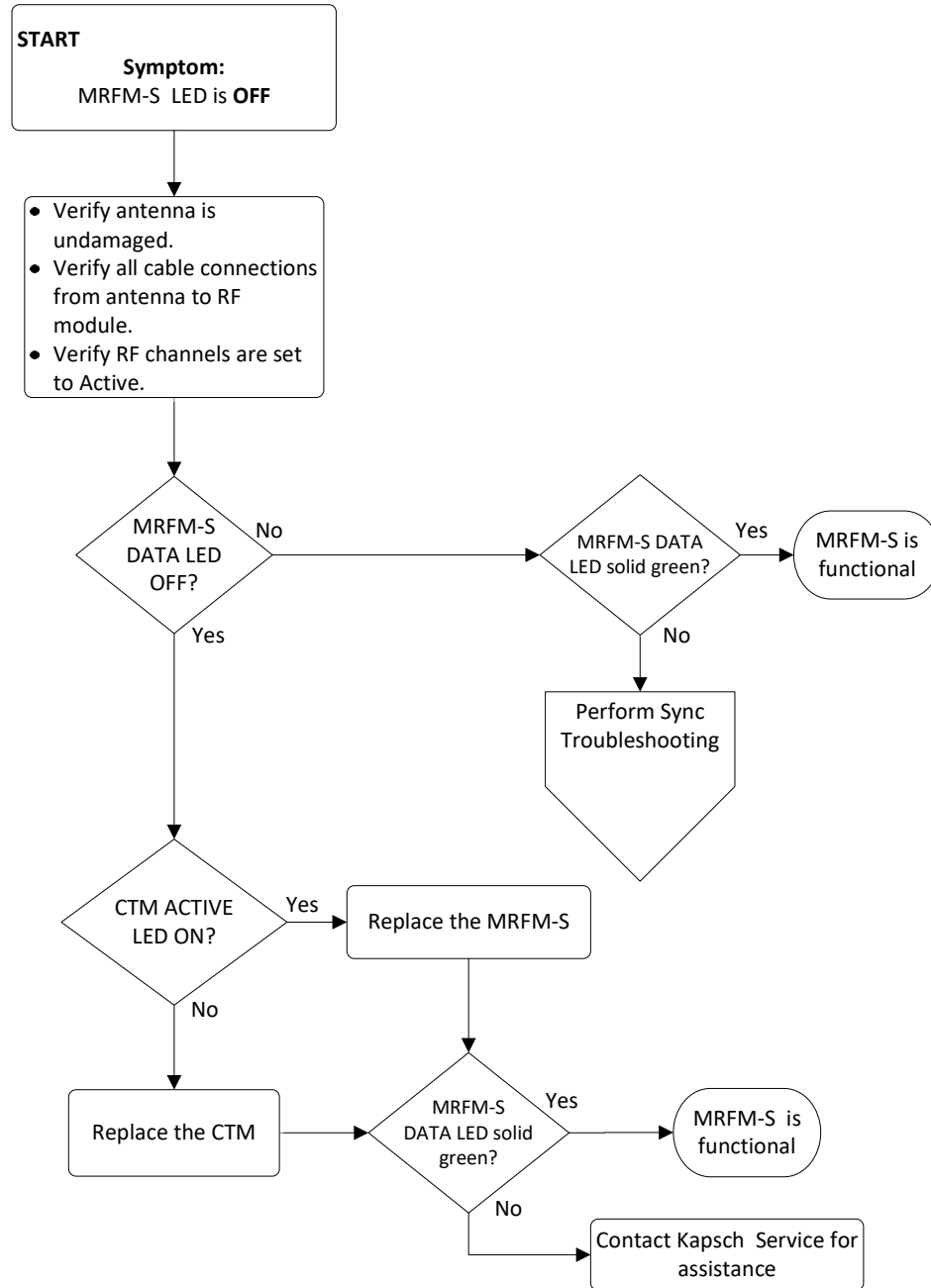

Troubleshooting tree: Synchronization not working

Active CTM

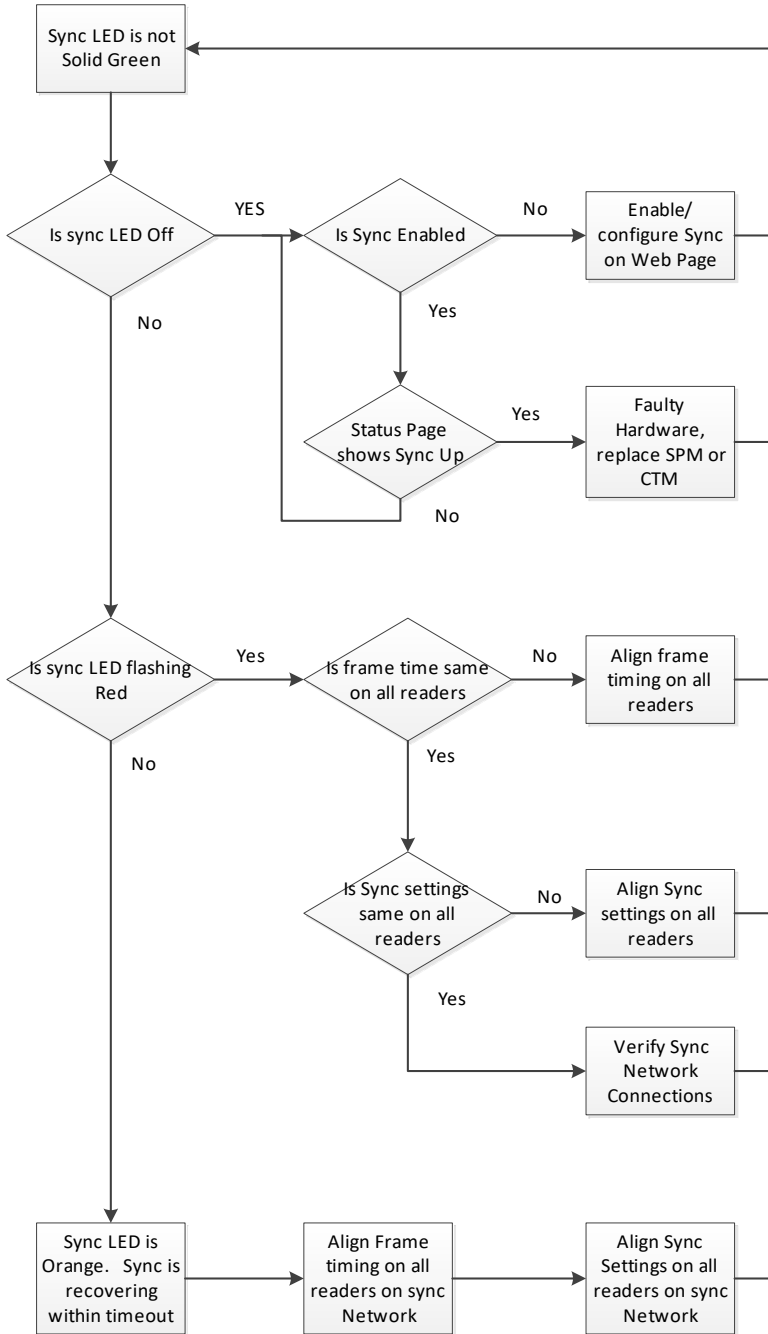

In - Active CTM

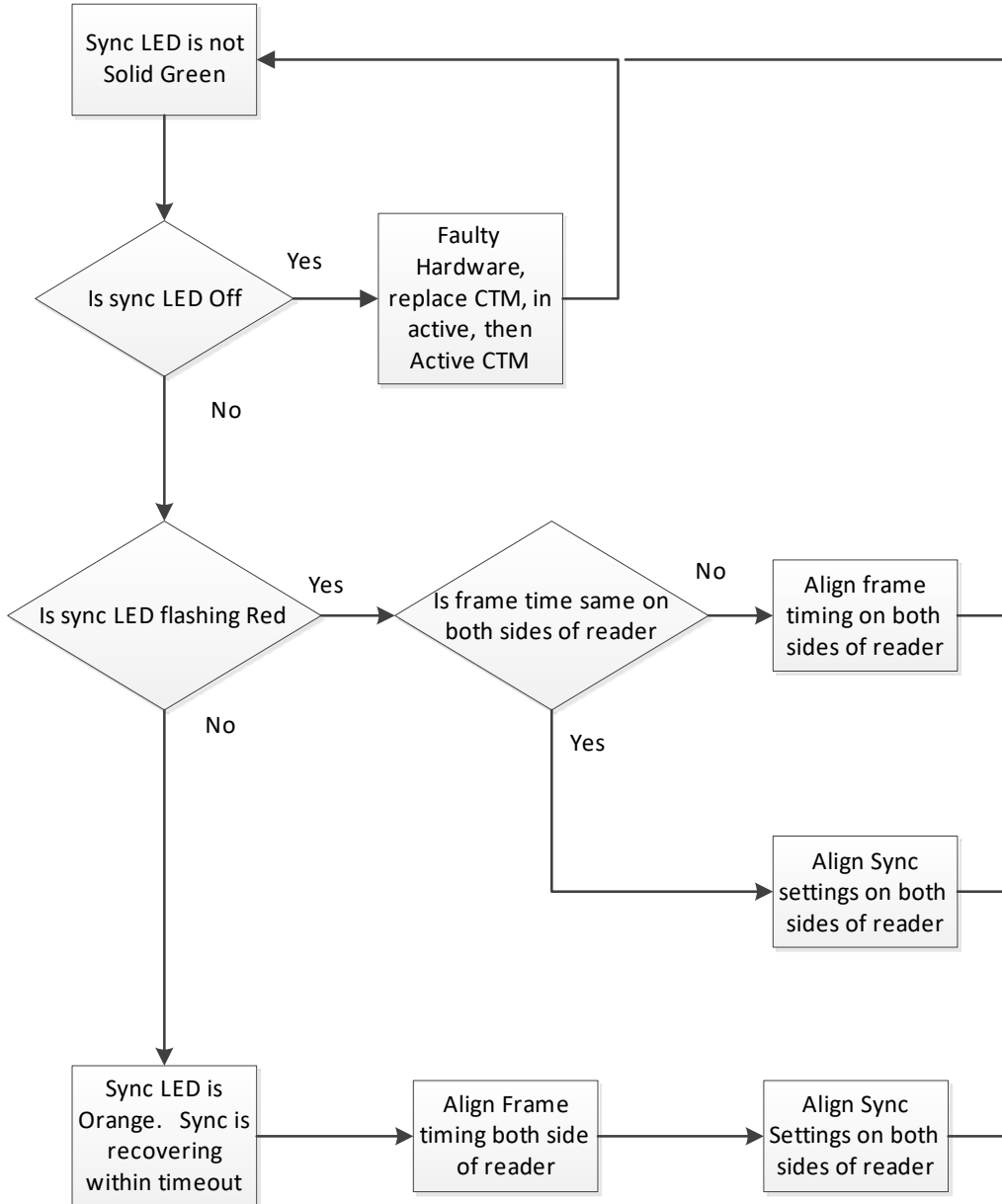

Constant busy state on sync bus

A Reader that erroneously holds the sync bus in a BUSY state causes all other Readers connected to the bus to time-out while waiting for the READY state. As a result, all of their CTM SYNC LEDs will be flashing red. Disconnect each Reader one at a time from the sync hub until the fault clears then reconnect each Reader in the order of removal until the fault reappears. Service each faulty Reader.

Sync board Failure Indicator for incomplete cable connections

The CTM SYNC LED will flash steadily red if there is no activity on the Rx port on the terminal block of the SPM (R+ and R- on the connector). If both transmit and receive connections are cut off from the sync hub the indicator will flash red. If only the transmit connection is disconnected and there are other Readers in the synchronization network, the CTM SYNC LED stays green.

Troubleshooting tree: Reader does not automatically switch back to Primary side after fault recovery

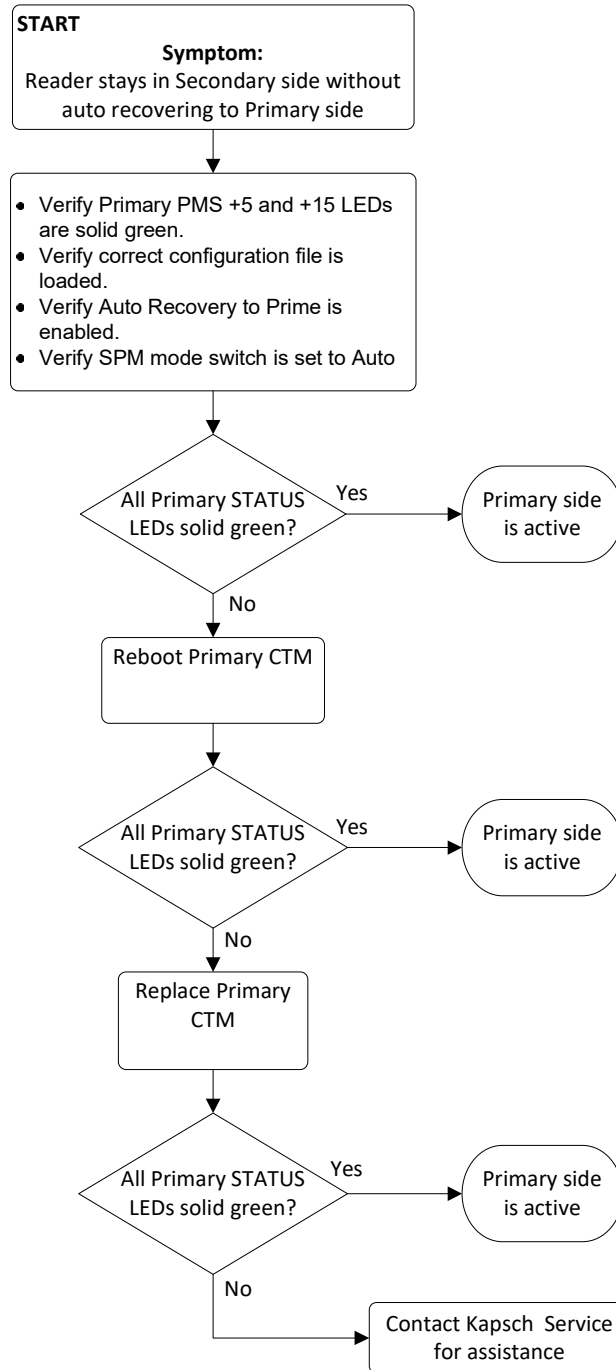

Troubleshooting tree: Simultaneous faults on Primary and Secondary CTMs

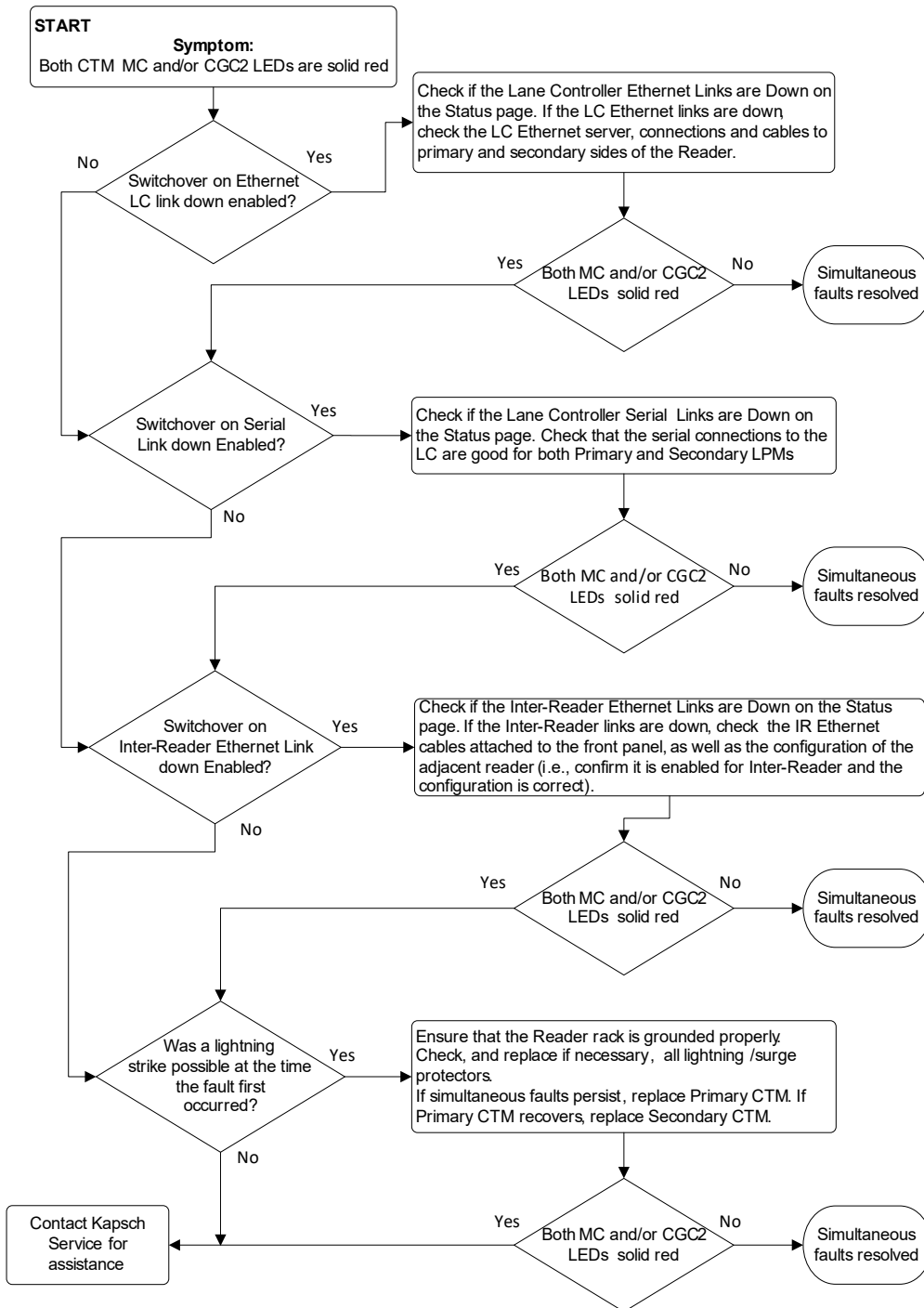

Identifying failures on the primary and/or secondary side

Primary and/or Secondary side failure is indicated by any of the following conditions:

- Ethernet LC link down, as indicated on the web page banner and Status page.
- Ethernet IR network link down, as indicated on the web page banner and Status page.
- Primary CTM MC or CGC LEDs are red
- Serial LC link down, as indicated on the web page banner and Status page.

Primary side failure is indicated by any of the following conditions

- SPM switch is in PRIMARY position: primary CTM ACTIVE LED is red
- SPM switch is in AUTO position: primary CTM ACTIVE LED is red

Secondary side failure is indicated by any of the following conditions:

- SPM switch in any position: secondary MC or CGC LEDs are red
- SPM switch is in SECONDARY position: secondary CTM ACTIVE LED is red
- SPM switch is in AUTO position: primary CTM ACTIVE LED is red and secondary CTM ACTIVE LED is red.

Events that cause an automatic switchover

Table 6-4 outlines the situations that can cause an automatic switchover and what settings need to be configured for the trigger to be enabled.

Table 6-4: Switchover triggers

Event	Cause	Enabling
Failed CGC Health	The Reader continuously monitors the CGC health and forces a switchover if health fails.	Automatic
Failed Serial Lane Controller Link	The Reader forces a switchover when an enabled serial link from the LPM to the LC has been interrupted. Usually a downed link is due to external conditions. Only the lack of OBU transactions in outgoing messages to the LC allows a downed link to be detected. To detect serial cable issues in the absence of OBU transactions, the operator must enable Heartbeat messages	Refer to Configuring Reader switch-over events, page 64
Failed Ethernet Lane Controller Link	The Reader forces a switchover when an enabled Ethernet link has failed. Usually a downed link is due to external conditions. A downed link is detected regardless of whether OBU transactions are being generated or not.	Refer to Configuring Reader switch-over events, page 64

Event	Cause	Enabling
Failed Inter-Reader Ethernet Link	The Reader continuously checks the link status of the IR network and forces a switchover if it fails.	Refer to Configuring Reader switch-over events, page 64
Reader Software Update	During activation of a different firmware version, the Reader switches automatically to the redundant side if the redundant side is running and has no switchover conditions present.	Automatic
Lane Controller Reboot	The lane controller protocol allows it to send a reboot request to the Reader. The Reader switches to the redundant side if the redundant side is running and has no switchover conditions present. If the redundant side is not functioning, the reboot is ignored.	Automatic
Web Interface Reboot	The web interface provides a reboot button. The Reader switches automatically to the redundant side if the redundant side is running and has no switchover conditions present.	Automatic
Reboot using CTM ON/OFF switch	When the CTM ON/OFF switch is manually switched from ON to OFF, the Reader will automatically switch over	Automatic when the switch on the CTM is manually set to OFF

Reader recovery actions

For certain failures, the Reader will automatically initiate the recovery actions outlined in Table 6-5.

Table 6-5: Failures and the Reader Recovery Actions they trigger

Failure	Reader Recovery Action
CGC Health failure	reinitializes CGC on failed side
Serial LC link down	re-attempts connection on failed side once every second
Ethernet LC link down	re-attempts connection on failed side once every second or up to 10 seconds based on load
Inter-Reader Ethernet link down	switches to Badger style CRA on failed side to re-attempt connection

Testing the CTM Ethernet 1 port

This test verifies that a CTM Ethernet 1 port is working properly.

Prerequisites: A service laptop.

1. Connect a service laptop directly to CTM Ethernet 1 port being tested. Refer to Connecting a service laptop to the Reader, page 43.
2. Check “ping” operation. If ping responds correctly, this confirms the Ethernet 1 port is functional.

Testing the Synchronization Circuit

This first part of this test checks the functionality of one Reader’s SPM. The second part of this test checks the Synchronization wiring from one Reader’s SPM to the synchronization circuit terminal block

Prerequisites: At least one RF module installed in the Reader. Both Primary and Secondary CTMs have the same configuration; synchronization enabled

Testing the SPM and CTM

1. Disconnect the Synchronization circuit wiring from the SPM terminal block

Using two short jumper wires connect Tx+ to Rx+ and Tx- to Rx- on the SPM terminal block, leaving the GND terminals unconnected (see SPM terminal block connections, page 228).

If the SYNC LED on both CTM’s illuminates solid green, the SPM and CTM’s are functioning properly.

Reconnect the synchronization circuit to the SPM terminal block.

Testing the Synchronization hub cabling

1. If the SYNC LED on the CTM does not illuminate solid green with a functional SPM and CTM connected to the Synchronization circuit, the problem is with the wiring between the SPM and the synchronization hub terminal block.

Testing the MRFM-S slots

The following test is to verify that all MRFM-S slots in the upper portion of the Reader rack are functional.

Prerequisites: Accessing the Reader web interface, page 43. One functional MRFM-S (Plus) is installed in the RF slot 1 of the Reader rack.

Note: All eight channels in the frame sequence configuration must be enabled to fire, otherwise this test will not work.

1. From the dashboard, select the **Channels** page.

Result: The following screen appears.

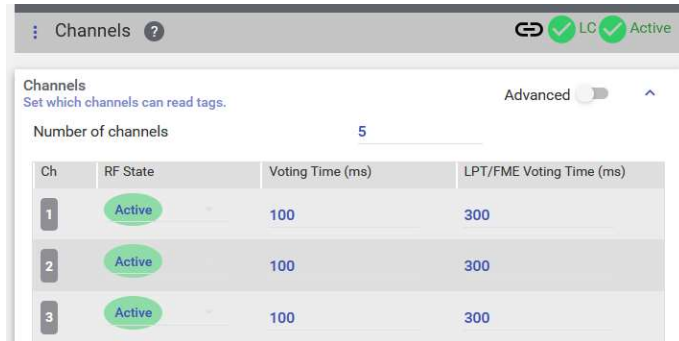

Set “Number of channels” to 8 if not currently set to 8.

Set the channel number (where the RF module is installed) to **Active**.

Ensure that the DATA LED on the RF module illuminates solid green.

From the **Channel** page, select **Offline** from the **RF State** drop-down box.

Ensure that the DATA LED on the RF module is off.

Move the RF module to the next slot and repeat steps 3 through 6.

Lane Check Diagnostic



Lane Check is a new reader diagnostic intended as a trouble shooting tool for use in a closed lane. It provides a measure of RF margin for a specific vehicle/OBU, and lane kit. This diagnostic should be used only on request from Kapsch.

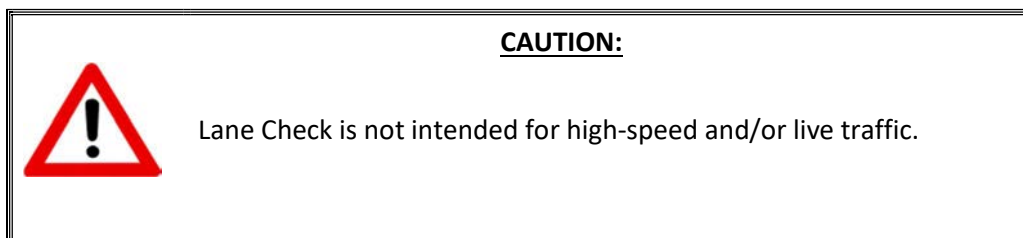

Prerequisites: Accessing the Reader web interface, page 43. Lane to check must be closed to live traffic.

1. On the **Tag Protocols** page, **select a single protocol**. Ideally the frame sequence duration should be as short as possible as this provides more lane check test samples. If multiple protocols are enabled, a result is provided only for the first protocol in the frame sequence.
2. From the reader Dashboard, select the **Lane Check**  link. Sample screenshot below.

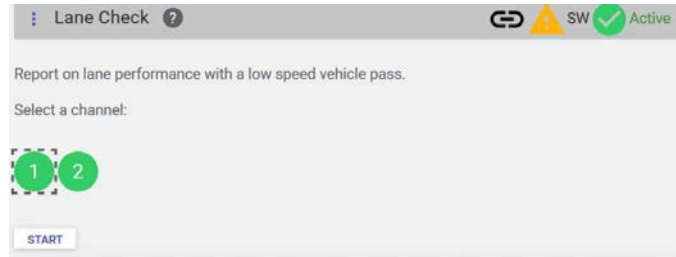

3. Select the RF channel to be checked, then click the START button.
4. Have a single vehicle with a properly mounted transponder traverse the associated capture zone at a slow steady pace (< 5 MPH). The exact speed is not important; a slow roll through is best.

Result: After the vehicle passage, the reader provides a margin result:



The result shows the maximum available downlink RF margin (in dB) recorded by the reader during the passage.

To get additional readings, repeat steps 3 and 4.

The margin result can be compared to the currently configured Tx attenuation for the specific protocol and channel. The margin result reported should be higher than the Tx attenuation determined during lane tuning.

7. MAINTENANCE PROCEDURES



WARNING:

THE MODULES MAY HAVE SHARP EDGES. HANDLE THE MODULES CAREFULLY. WHENEVER POSSIBLE, USE A MODULE EXTRACTION TOOL TO REMOVE A MODULE.



CAUTION:

Improper modification of configuration parameters may adversely affect system operation. The default values may not be appropriate for the specific application. It is the system integrator's responsibility to tailor the configuration parameters to the specific operating environment.



CAUTION: Redundant Reader

Both CTMs in a redundant Reader must be properly configured. Each CTM has its own browser interface and is configured independently, unless Configuration Alignment is enabled. If Configuration Alignment is not enabled, ensure any configuration changes made to one CTM are applied to the other CTM, as required.

Corrective maintenance procedures

Note: When removing or installing ESD sensitive equipment always follow the accepted practices for ESD protection.

The **inspect, clean, and system re-test** methodology is used for all system maintenance. This type of maintenance consists of the following general steps.

1. Inspect all Reader sub-system components and connections.
 - Inspect the PSM fuses; they should not appear darkened or burned.
 - Make sure that all plug-in components are properly seated in their mating connectors.

Determine if the components and/or connections require cleaning. To clean component assemblies, use a portable vacuum cleaning tool with a non-conductive tip/brush. To clean component connector contacts, use a contact cleaner spray that does not contain a trichloroethylene based solvent or a Freon® based propellant.

Attention: Pre-authorized lane closure is required if the MRFM-S (Plus) modules need to be cleaned.

If cleaning is required:

Activate the side of the Reader not being cleaned (see Manually switching a Reader to the redundant side page 45).

Power down the side of the Reader to be cleaned.

Clean the components and connections and then Power up and activate this Reader side.

Power down the remaining Reader side.

Clean the components and connections then Power up and activate, if necessary, this Reader side.

Test all system functions (see Troubleshooting and Testing, page 183).

Preventive maintenance procedures and scheduling

Attention: Only Kapsch Service-trained service maintenance personnel are to perform these tasks.

Once a year:

1. Perform RF measurements to verify the cables and MRFM-S (Plus). It is recommended a commercial off-the shelf instrument is used which supports Cable Analyzer Testing, to show faults inside cables, and Voltage Network Analysis, to verify connection integrity and end to end connectivity and gain.

Verify module output power and power at antenna using a commercial off-the shelf spectrum analyzer.

With power off:

1. Inspect and clean the Reader cabinet as needed, depending on the site environmental conditions, such as contamination by dust. As a minimum, inspect and clean the cabinet interior and components once per year.

Inspect the antenna waterproofing and ensure that any seal is secure.

Inspect the antenna weep hole. Remove any dust, dirt or other obstructions.

Check ground connectivity for exterior ground connection to reader system ground

Attention: Pre-authorized lane closure is required before continuing with this procedure.

Note: For each channel, go into the web interface and disable the channel to be tested.

1. Disconnect and inspect in-line lightning suppressor.

Disconnect and inspect the exterior RF feedline cable and connectors exposed to the elements.

If corrosion is visible, replace the corroded connector and, if necessary, cut out the entire corroded portion of the feedline cable. The antenna may require replacement if the mating female connector is corroded.

When reconnecting connectors after inspection is complete, discard and replace self-amalgamating tape.

Every 4 1/2 years:

Note: The CMOS battery is not field-replaceable.

1. Replace the CTM CMOS battery.

Note: If a Kapsch TrafficCom maintenance agreement is in place, the CTM needing a new battery can be replaced by a spare CTM. The CTM is then sent to Kapsch Service to have its battery replaced.

MRFM-S (Plus) replacement

The Reader does not need to be shut down to replace an MRFM-S (Plus)

Prerequisites: Accessing the Reader web interface, page 43.



WARNING:

THE MODULES MAY HAVE SHARP EDGES. HANDLE THE MODULES CAREFULLY. WHENEVER POSSIBLE, USE A MODULE EXTRACTION TOOL TO REMOVE A MODULE.



WARNING:

THE MRFM-S (PLUS) MAY BECOME HOT UNDER NORMAL OPERATING CONDITIONS. ENSURE THE MRFM-S (PLUS) HAS COOLED DOWN OR WEAR GLOVES WHEN HANDLING THE MRFM-S (PLUS).

Removing an MRFM-S (Plus)

1. Select the **Channels** page.

Result: The following screen appears.

Ch	RF State	Voting Time (ms)	LPT/FME Voting Time (ms)	Channel Weight (%)	Group #	Dynamic Voting
1	Active	100	1	100	0	Disabled
2	Active	100	1	100	0	Disabled
3	Active	100	300	100	0	Disabled
4	Active	100	300	100	0	Disabled
5	Active	100	300	100	0	Disabled
6	Active	100	300	100	0	Disabled
7	Active	100	300	100	0	Disabled
8	Active	100	300	100	0	Disabled

2. Set the RF State of the active MRFM-S (plus) to Offline.

Note: Disconnect the RF cable(s) from the MRFM-S (Plus) appropriate port.

3. Loosen the screws securing the MRFM-S (Plus) module to the Reader rack, and then remove the MRFM-S (Plus) from the Reader.

Installing an MRFM-S (Plus)



CAUTION:

To avoid damaging the modules, ensure that the connector on the module is properly aligned with the connector on the DSM back plane before the module is securely plugged into the DSM.

1. Insert the MRFM-S (Plus) module into the Reader. Tighten the screws to secure the MRFM-S (Plus) to the Reader rack.
2. Connect the RF cable(s) to the MRFM-S (Plus) appropriate port and tighten with a proper torque wrench.
3. Select the Channels page.
4. Set the the Offline MRFM-S (Plus) channels back to Active.
5. Verify the DATA LED illuminates solid green.

Note: If the DATA LED does not illuminate solid green, see Troubleshooting tree: MRFM-S (Plus) not working, page 190.

6. Verify module output power and power at antenna using a commercial off-the-shelf spectrum analyzer.
7. Ensure the RF channel is capturing OBU data (see Troubleshooting tree: MRFM-S (Plus) not working page 190).

Antenna replacement

Note: The Reader does not need shutting down to replace an antenna.

Prerequisites: Refer to Accessing the Reader web interface, page 43.

Removing an antenna

1. Select the **Channels** page.
2. Set the the MRFM-S (Plus) connected to the antenna to Offline.
3. Remove the antenna.

Installing an antenna

1. Install the antenna (see Installing an Antenna, page 159).
2. Select the Channels page.
3. Set the Offline MRFM-S (Plus) back to Active.
4. Verify the DATA LED illuminates solid green.

5. Verify module output powers and power at antenna using a commercial off-the shelf spectrum analyzer .
6. Ensure the MRFM-S (Plus) is capturing OBU data.

RF cable or connector replacement

Note: The Reader does not need shutting down to replace an RF cable or connector.

Prerequisites: Connection to reader, refer to Accessing the Reader web interface, page 43.

Removing RF cable/connector

1. Select the **Channels** page.
2. Set the RF State of the MRFM-S (Plus) whose cable or connector is being replaced to Offline.
3. Remove the RF cables or connectors.

Installing an RF cable/connector

Prerequisites: Self-amalgamating tape for connections.

1. Install the RF cables or connectors.
2. Apply new self-amalgamating tape to the connections.
3. Select the Channels page.
4. Set the Offline MRFM-S (Plus) RF State back to Active.
5. Verify that the DATA LED illuminates solid green.
6. Verify module output powers and power at antenna using a commercial off-the shelf spectrum analyzer.
7. Ensure the MRFM-S (Plus) is capturing OBU data.

CTM replacement

WARNING:



THE MODULES MAY HAVE SHARP EDGES. HANDLE THE MODULES CAREFULLY. WHENEVER POSSIBLE, USE A MODULE EXTRACTION TOOL TO REMOVE A MODULE.

**CAUTION:**

Removing a powered CTM from the Reader rack can damage the CTM. Before removing a CTM from the Reader, ensure that power on the affected side of the Reader is turned off, i.e. the power switch on the PSM is in the off position, or the PSM AC input power cord is disconnected.

Removing a CTM

1. Switch the Reader over to the side with the CTM that is **not** being replaced (see Manually switching a Reader to the redundant side, page 45).
2. Set the PSM powering the CTM being replaced to the off position.
3. Label and then disconnect any communication cables connected to the CTM.
4. Remove the faulty CTM from the Reader rack.

Installing a CTM**CAUTION:**

To avoid damaging the modules, ensure that the connector on the module is properly aligned with the connector on the DSM back plane before the module is securely plugged into the DSM.

1. Install a new CTM in the Reader Rack.
2. Reconnect the communication cables to the CTM.
3. Set the PSM and CTM to the on position.
4. Switch the Reader to the new CTM side (see Manually switching a Reader to the redundant side, page 45).

SPM replacement

WARNING:



THE MODULES MAY HAVE SHARP EDGES. HANDLE THE MODULES CAREFULLY. WHENEVER POSSIBLE, USE A MODULE EXTRACTION TOOL TO REMOVE A MODULE.

Removing an SPM

1. Without disconnecting any of the sync wiring from the SPM terminal block, disconnect the SPM terminal block from the SPM.
2. Remove the SPM from the Reader rack.

Installing an SPM

CAUTION:



To avoid damaging the modules, ensure that the connector on the module is properly aligned with the connector on the DSM back plane before the module is securely plugged into the DSM.

1. Install a new SPM in the Reader Rack.
2. Reconnect the SPM terminal block.
3. Test the SPM (see Testing the Synchronization Circuit, page 199).

LPM replacement

WARNING:



THE MODULES MAY HAVE SHARP EDGES. HANDLE THE MODULES CAREFULLY. WHENEVER POSSIBLE, USE A MODULE EXTRACTION TOOL TO REMOVE A MODULE.

Removing an LPM

1. Switch the Reader over to the side with the LPM that is not being replaced (see Manually switching a Reader to the redundant side, page 45).
2. Remove the faulty LPM from the Reader rack.

Installing an LPM

1. Install a new LPM in the Reader rack.
2. Switch the Reader back over to the new LPM side (see Manually switching a Reader to the redundant side, page 45).
3. Test all the LPM COM ports.

PSM replacement**WARNING:**

THE MODULES MAY HAVE SHARP EDGES. HANDLE THE MODULES CAREFULLY. WHENEVER POSSIBLE, USE A MODULE EXTRACTION TOOL TO REMOVE A MODULE.

WARNING:

THE PSM MAY BECOME HOT UNDER NORMAL OPERATING CONDITIONS. ENSURE THE PSM HAS COOLED DOWN OR WEAR GLOVES WHEN HANDLING THE PSM.

WARNING:

EXPOSED HIGH VOLTAGE IS PRESENT IN THE PSM. ENSURE THAT THE POWER SWITCH IS SET TO THE OFF POSITION AND THAT THE AC INPUT POWER CORD IS DISCONNECTED BEFORE REMOVING THE PSM.

Removing a PSM

1. Switch the Reader over to the side with the PSM that is not being replaced (see Manually switching a Reader to the redundant side, page 45).
2. Set the PSM power switch to the off position.
3. Remove the faulty PSM from the Reader rack.

Installing a PSM**CAUTION:**

To avoid damaging the modules, ensure that the connector on the module properly aligns with the connector on the DSM back plane before the module is securely plugged into the DSM.

1. Install a new PSM in the Reader Rack.
2. Set the power switch of the new PSM to the on position.
3. Ensure that the new PSM +5 and +15 LEDs illuminate solid green.
4. Switch the Reader back over to the new PSM side (Manually switching a Reader to the redundant side, page 45).

CFM replacement**WARNING:**

THE MODULES MAY HAVE SHARP EDGES. HANDLE THE MODULES CAREFULLY. WHENEVER POSSIBLE, USE A MODULE EXTRACTION TOOL TO REMOVE A MODULE.

Removing a CFM

1. If possible, save the reader configuration to a file (see Saving the Reader configuration, page 215).
2. Remove the CTM on the side of the faulty CFM (see CTM, page 206).
3. While pushing on plastic clips, pull CFM straight out from DSM.

Installing a CFM

1. Push CFM straight into connector on DSM until an audible click is heard.
2. Install the CTM removed in step 2 (see CTM, page 206).
3. Load the configuration file saved in step 1 to the new CFM (see Loading a reader configuration, page 215), or locate and upload the latest saved Reader configuration.

Replacing a PSM fuse



1. Set the PSM power switch to the off position.
2. Disconnect the AC power cord.
3. Using a flat-tipped screwdriver, rotate the fuse holder counter-clockwise 180 degrees. Slide out the fuse holder as shown in Figure 7-1.

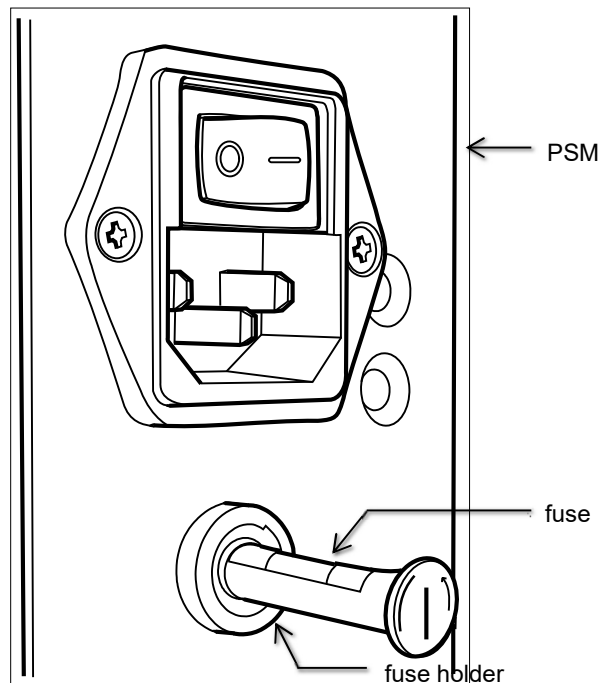

Figure 7-1: PSM fuse and fuse holder

4. Rotate the fuse holder clockwise to allow the old fuse to fall free of the fuse holder.
5. Place the new fuse in the fuse holder then slide the fuse holder into the PSM.
6. Using a flat-tipped screwdriver, rotate the fuse holder 180 degrees to secure the fuse holder in the PSM.

Rebooting the CTM

This procedure outlines two ways of rebooting the CTM

Rebooting from the reader web interface (preferred method)

Prerequisites: Accessing the Reader web interface, page 43.

1. From the Dashboard page, click the  button and confirm the operation.

Result: The CTM starts to reboot.

Rebooting using CTM ON/OFF switch

1. Set the CTM ON/OFF switch to OFF.
2. After five seconds, set the CTM ON/OFF switch back to ON. The CTM POWER LEDs immediately illuminate solid green. After 90 – 120 sec., the CTM STATUS LEDs illuminate their normal state (see LED Status, page 185).
3. Set the toggle switch on the SPM to the side to stay active, either SECONDARY or PRIMARY.

Result: This side is now active and no switchover will occur unless a failure occurs.

Configuring the Reader to switch over automatically when an LC link is down

1. From the home page, click the **Lane Controller** button to get to the Lane Controller page:

Ensure that LC communications is configured, that is, the appropriate **Ethernet** and **Serial** selections are made in the **Destinations** field.

For serial connections, review these settings:

LC Serial
Configure serial ports to lane controller.

LC Retry Timeout (ms):	1000
Send Serial Heartbeats:	<input type="checkbox"/>
Serial Heartbeat Interval (sec):	2

Send Serial Heartbeat should only be enabled if the Lane Controller is able to respond to heartbeat messages. **LC Retry Timeout**

Navigate to the **General** page, and review the Switchover panel:

Switchover ^

Switchover on Ethernet LC link down:	<input type="checkbox"/>
Switchover on Inter-Reader link down:	<input type="checkbox"/>
Switchover on serial LC link down:	<input type="checkbox"/>

Toggle **Switchover on serial LC link down** and/or **Switchover on Ethernet LC link down**, as required.

Note: When setting the LC Retry Timeout, consider the baud rate used to communicate with the LC and the processing speed of the LC to avoid false failure reports.

If **Switchover on Serial Link Down** is enabled, from the **LC Serial** panel on the **Lane Controller** page, enter a time, in milliseconds, in the **LC Retry Timeout** field. If an LC does not respond within this time, the Reader will consider serial communications to the LC to be down and will trigger a switchover if the SPM redundancy mode switch is in **AUTO**.

If **Switchover on Ethernet LC Link Down** is enabled, enter a time, in milliseconds, in the **LC Ethernet TCP-Socket Timeout** text box. If an LC does not respond within this time, the Reader will consider Ethernet communications to the LC to be down and could trigger a switchover if the SPM redundancy mode switch is in **AUTO**.

Updating Reader Software

Periodically, Kapsch Service will release a new version of the Reader software/firmware in a single file. The software names indicate the year, month, day, and revision number of the release.

Uploading new firmware

Prerequisites: Accessing the Reader web interface, page 43. A reader software update file. **Manage Software** permissions.

1. From the home page, click on the **Reader SW** button. The following screen should appear.



2. Click the  button, and a window opens to select the reader software update file on your laptop.
3. Select the reader SW update file and confirm the selection.

Result: After the software has finished uploading to the Reader, it will be listed in the **Other Available Software Versions** table. Note this step only transfers the software to the reader. The next step is to Activate (run) it.

Activating new software

Activating software means switching to a different version of software that is currently active. Typically, the newest software uploaded to the reader would be activated.

Prerequisites: **Manage Software** permissions. The primary and secondary sides of the Reader are running normally. The required software has been uploaded to the Reader (see above).

CAUTION: Redundant Reader

During software/firmware activation the Reader will switch over to the other side to process and report transactions, regardless of the position of the mode switch on the SPM module. Ensure that the other side is running normally and all lane controller links are functioning. The Reader will be unable to process or report transactions if it is unable to switch over to the other side.

CAUTION: Non-Redundant Reader

During software/firmware activation (typically less than 60 seconds), a non-redundant Reader is unable to process or report transactions.

On the Primary side:

The current reader settings are maintained between software updates, so it is not necessary to save settings before activating a new version.

1. From the **Other Available Software Versions** table on the **Reader Software** page, identify and click on the version to be activated.
2. Click the Activate  button to activate the software. Click to acknowledge. There will be a delay before the software becomes active.
3. Unless instructed otherwise, repeat the above steps on the Secondary side to ensure both sides are running the same software.



The reader automatically checks if both sides of a redundant reader have the same software version, and will indicate  in the web banner if the software versions are different. If the indicator is absent, it means the software versions match.

Deleting software

This procedure outlines the steps for deleting an inactive software version stored on the Reader. The Factory software and active software cannot be deleted.

Prerequisites: You must have Manage Software permissions.

1. From the **Other Available Software Versions** section of the **Reader Software** page, select a version to be deleted.
2. Click the Delete  button.

3. Click Yes to confirm.

Result: The software will be deleted and will no longer appear in the software version table.

Configuration management

Prerequisites: Accessing the Reader web interface, page 43. Change Configuration permission. If the  symbol is shown in the banner, you can view but not change the reader configuration.

Saving the Reader configuration

The current reader configuration can be saved to a text file, which can be useful for the following situations:

- Quickly configure another Reader requiring the same or similar configuration.
- Restore the Reader to a known configuration.
- Troubleshoot problems by comparing the current configuration to past configurations.

1. From the home page, click the **Save/Load** button from the Configure panel.

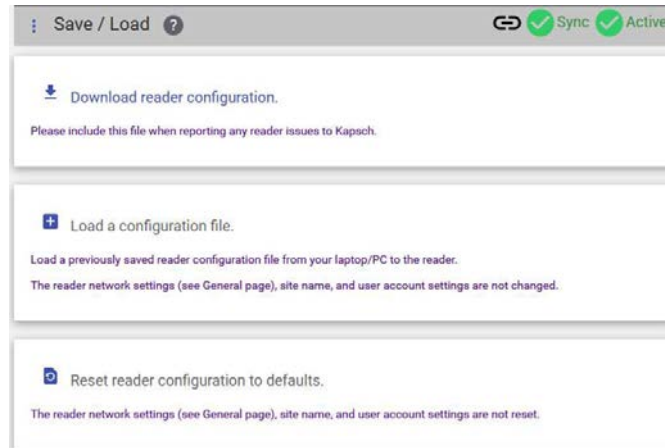

2. Click the Download reader configuration  button to save the current configuration. The browser should offer to download, or automatically download (depending on browser settings) the reader configuration file to the laptop.

Result: The reader configuration file is saved to your laptop (typically the Downloads folder).

Loading a reader configuration file

Uploading a previously saved configuration overwrites the current reader configuration. Some parameters (reader network settings, site name, and user account settings) are not modified. Only load a configuration file saved from the same model of JANUS reader.

**CAUTION:**

Improper modification of configuration parameters may adversely affect system operation. It is the system integrator's responsibility to load configuration parameters relevant to the specific operating environment.

1. From the **Save / Load** page, click the  button to locate a previously saved configuration file.
2. In the confirmation dialog click "Yes" load the configuration settings from the file.
3. Settings are applied immediately. A reboot is not required.

Resetting the Reader configuration to the factory default

Certain field service tests use the factory default configuration. This procedure outlines how to restore the factory default settings.

**CAUTION:**

The factory default configuration should not be restored on a running Reader. Save the current Reader configuration before resetting the Reader configuration to the factory default, in case you want to recover previous settings.

1. Click on the **Save / Load** button on the Configure panel of the reader home page.
2. Click the Reset Parameters to Default Values  button.

Result: All configuration values, except for the Reader network settings, site name, and user account settings, revert to the factory defaults. A reboot is not required.

User Administration

User administration permissions are needed when a new user account needs to be created, when an account needs to be changed, or deleted. The user can be given any combination of the following permission attributes:

- Admin User
- Manage Software (permission to update / change running version of reader software)
- Manage Logs (permission to download or delete logs)
- Change Configuration (permission to change reader settings)

Prerequisites: Accessing the Reader web interface, page 43. **Admin User** permissions.

Creating a new user

This procedure outlines how to create a new user account, create a password, and set the user permissions.

1. From the home page, click the **Users** button on the Manage panel.

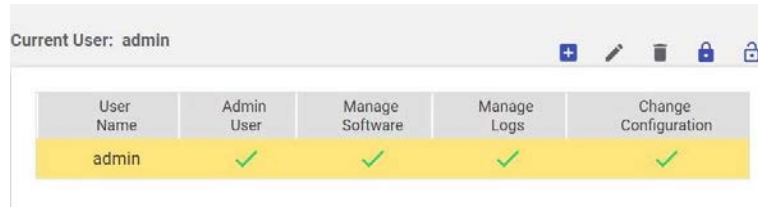

2. Click the button.

Result: The following screen appears.

Add User

user name

password

retype password

Admin User

Manage Software

Manage Logs

Change Configuration

SAVE CANCEL

3. Enter a unique user name in the User Name field.
4. Enter the new user’s password in the Password and confirm password in Retype Password field.
5. Toggle any of the permission attributes for the new user.
6. Click SAVE to create the new user account and return to the Users panel.

Note: If you decide not to create the user at this time, click Cancel to return to the Users panel

Changing a user’s access permissions

1. From the home page, click the **Users** button on the Manage panel to get to the User’s page:

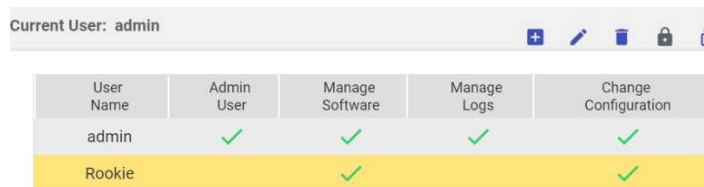

2. Select a user from the list (click on the row).
3. Click on the button.

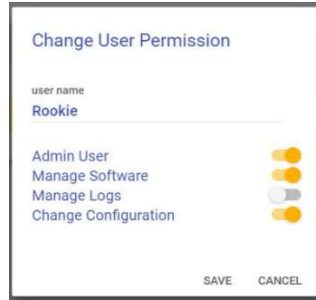

4. Adjust the permission attributes via the toggle switches and click SAVE.

Result: The user access permissions are updated.

Deleting a user

Use this procedure to remove a user's access to the reader web interface.

1. From the home page, click the **Users** button on the Manage panel.
2. Select the row containing the user to be removed.
3. Click the Delete  button.
4. Click Yes to confirm.

Result: The user account is removed and can no longer log in to the reader web interface.

Verifying which CTM a web session is interacting with

This operation helps when dealing with multiple readers in a cabinet, by flashing the MC indicator on the reader front panel indicator for a few seconds. This can help identify which CTM is being addressed by the web interface.

Prerequisites: Accessing the Reader web interface, page 43.

1. From the home page, click on the **Identify** button.
2. After the confirmation, examine the MC indicator of the CTM and confirm it flashes between Red / Amber / Green for a few seconds.

Network Time Protocol

NTP time sync can be used when a single reader is in use, as well as multiple readers, to align time with a NTP server.

Enabling NTP

Prerequisites: The Reader must be on a network that has access to an integrator supplied NTP time server(s). The IPv4 address of the NTP server(s) must be known. Accessing the Reader web interface, page 43. You must have **Change Configuration** permission.

1. From the home page, click on the **Time** button in the Configure panel. Alternate: Click on the reader time in the banner. Alternate: From the banner menu, select **Time**.

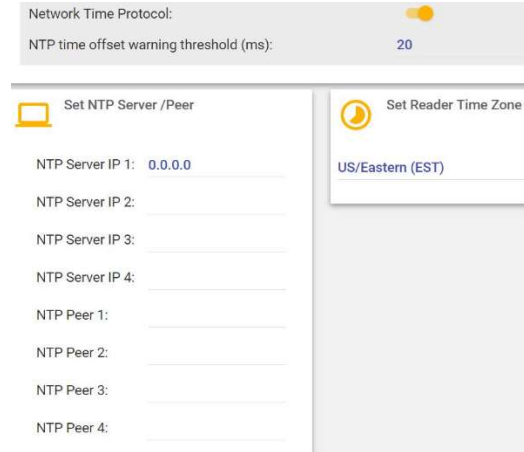

2. Enable the Network Time Protocol switch if not already enabled.



Review the **NTP time offset warning threshold** limit in milliseconds. The reader periodically checks that its time offset is less than the limit. If above, it shows an alarm in the banner.

3. Enter at least one NTP server IP address (MUST be an IPv4 dotted address, not a server name).
4. Review the time zone setting and adjust if desired. NOTE: The web interface may be temporarily unavailable for a short period after this step. You may see a “Reader Comms” warning in the banner, this is normal.

Result: If NTP time sync is operational and the time offset is less than the specified limit, the status bar

indicates  NTP. This can take up to a minute or so if setting up a new NTP server.

Manually setting the Reader time and date

This procedure outlines how to set manually the Reader time, in case of a new setup where NTP is not available yet, or a Lane Controller is not yet connected.

Prerequisites: Accessing the Reader web interface, page 43.

1. From the reader dashboard, click the Time button on the Configure panel. As a short-cut, you can click on the reader time in the banner.

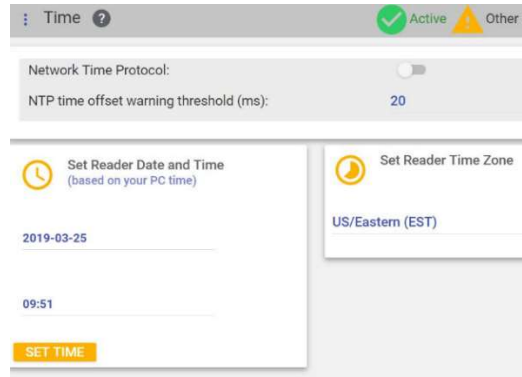

2. If the Network Time Protocol setting is currently enabled, disable it first via the toggle switch.
3. The time shown defaults to your current laptop time. Click on either the date or time field to make adjustments, as needed.
4. Click the Set Time button.
5. Review the time zone and adjust if desired. NOTE: The web interface may be temporarily unavailable for a short period after this step. You may see a “Reader Comms” warning in the banner, this is normal.
6. Repeat this procedure on the other reader side.

Result: The Reader time updates to the selected time.

Saving Reader Log files

Saving individual Reader logs files your laptop

This procedure outlines how to save a reader log file to your laptop.

Prerequisites: Accessing the Reader web interface, page 43.

1. Select the **Logs** link on the Manage panel of the home page.

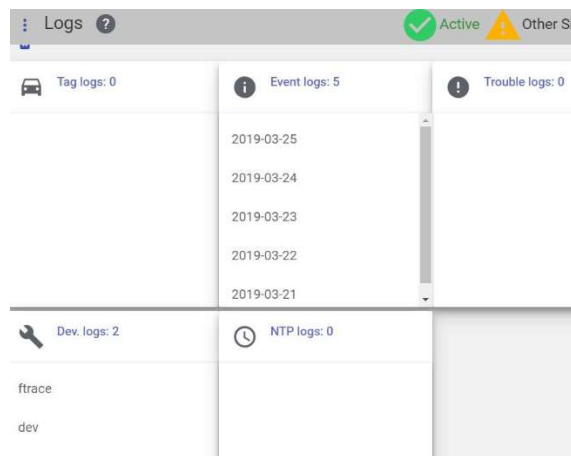

2. Select a log file; it opens in another browser tab.

3. Right-click for a pop-up menu, then select “Save as...” or “Save Page As...” , then save the file to your laptop.

Result: The log file is saved to the laptop.

Downloading all Reader logs as a compressed archive



This procedure describes how to download all reader logs as a single compressed archive.

Prerequisites: Accessing the Reader web interface, page 43. **Manage Logs** permission.

1. Select the **Logs** link on the Manage panel of the home page.
2. Click on the  (Download logs) button. Be patient as it takes a some time for the reader to compress the logs into an archive, especially if there are large log files.

Result: When the reader is ready to download the log file archive, you should see a window appear similar to the following:

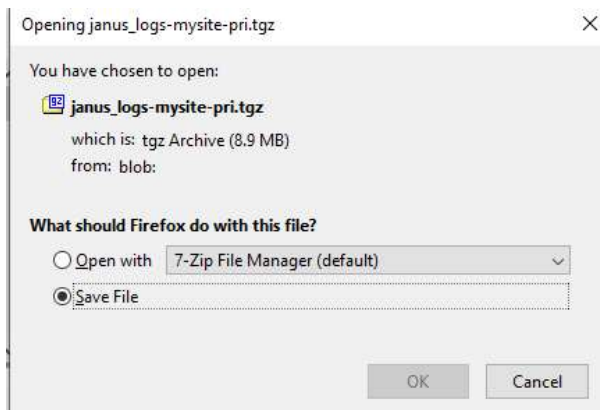

3. Click OK to save the log file archive to your laptop. You can open the archive with a third-party tool such as 7-Zip.

Result: The log archive is saved to the laptop.

Saving all Reader logs to a USB stick

This procedure outlines how to save all reader log files to a USB device plugged in to the reader.

Prerequisites: Accessing the Reader web interface, page 43. **Manage Logs** permission.

1. Insert a USB stick into one of the CTM USB ports. Wait a few seconds for the OS to recognize the device.
2. Select the **Logs** link on the Manage panel of the home page
3. Click on the  (Copy logs to USB) button and then confirm the operation.

Result: If the USB device is recognized, the banner will indicate  while the reader logs are being transferred to the USB device. **NOTE:** If you do not see the USB indicator, it likely means the USB device is not recognized by the reader. Please try another USB device.

4. When the  indicator goes away, the log file transfer is complete.
5. Remove the USB device from the reader. **NOTE:** The USB stick is automatically “ejected”, so must be removed before the above procedure can be repeated.

Appendix A Miscellaneous

Using PuTTY to connect to the DIAGNOSTIC PORT

1. Launch PuTTY.

Select **Serial** as your Connection Type.

Select the computer COM port that is connected to the Diagnostic Port.

Enter **115200** in the **Speed** text box.

Click **Open**.

Result: The following configuration screen appears.

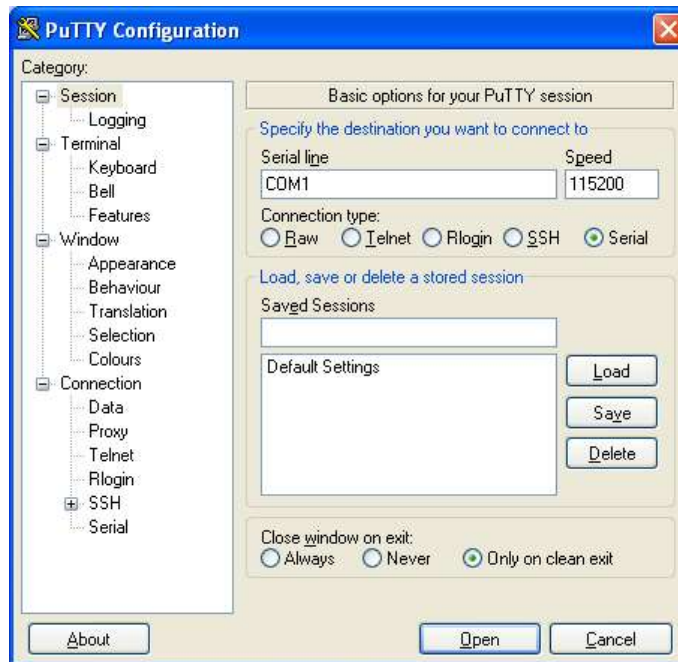

Press **Enter** a few times until the login prompt appears.

Using HyperTerminal to connect to the DIAGNOSTIC PORT

1. Go to **Start** → **Run**.
2. Type `hypertrm`, and then click **OK**.
3. In the **Connection Description** pop-up, enter a session name and then click **OK**.
4. In the **Connect To** pop-up, select the COM port that is connected to the Diagnostic Port from the **Connect Using** drop-down box.

5. Click OK.

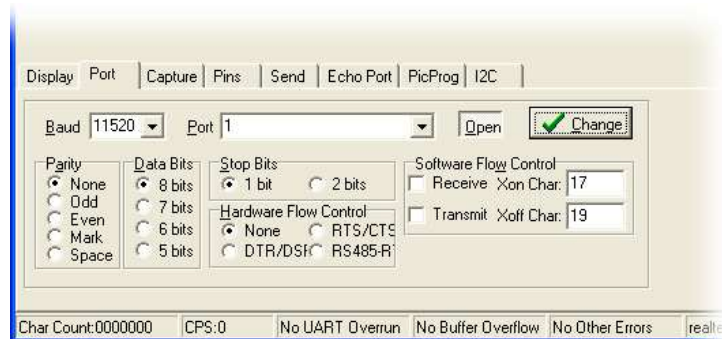

6. From the Display panel, select Binary from the Display As column.

MRFM-S (Plus) data now displays in the display pane in the upper half of the **RealTerm** window.

Accessing Documentation

You can access the documentation package for the JANUS reader online at <http://dds.kapsch.ca>. A Username and Password can be obtained from Kapsch Service.

The documentation package includes the following.

- Bill of Materials
- Assembly Drawings
- Schematic Drawings
- Parts Specifications (for purchased items)
- Operator and Maintenance Manuals
- Quick Start Guide
- Installation Instructions
- Training slides
- Software Design Documents: Context Diagrams, Data Flows
- As-built installation drawings (services)

Technical Specifications and Pin outs

JANUS® Multi-Protocol Reader 2.4 Technical Specifications		
Operation subject to FCC Site licensing (per FCC Part 90, Subpart M)		
Dimensions (excluding enclosure)		
Height = 17.5 inch	Width = 19.06 inch	Depth = 11.30 inch
Weight (excluding enclosure)		
Redundant Reader, with all slots filled: 63 lbs. (Not including MRFM-S)		
Enclosure Requirements		
NEMA 4 rated		
Operating Temperature Range		
-29.2°F to +165.2°F (-34°C to +74°C) For operation above 131°F (55°C) a 300CFM fan tray is required.		
Power Requirements		
300W UL/CSA power supply. Minimum of two, 3-prong IEC-320 receptacles (not supplied).		
PSM Ratings		
95-230 VAC, 60 +/- 2 Hz, 5A. One capable of supplying full load on redundant systems.		
Software		
Latest release available at delivery. Reader ships with default configuration settings.		
Memory Capacity		
1,000,000 buffered transactions.		
RF Channel Capacity		
Lane-based channels: maximum of 8. ORT channels: maximum of 8.		

NEMA 4 Enclosure Specifications		
Kapsch TrafficCom Field Cabinet Part Numbers		
Left hinged: 800127-101	Right hinged: 800127-102	
Dimension		
Height = 36 inch	Width = 30 inch	Depth = 20 inch
Enclosure Requirements		
<p>A 6 to 8-inch clearance between the top and bottom of the Reader and enclosure.</p> <p>Located for ready maintenance access.</p> <p>Location limited by maximum RF and Synchronization cable run length.</p>		
Construction		
-Aluminum with stainless steel components	-Neoprene gasket	
-Installed a 19-inch equipment rack for Reader mounting	-Universally keyed lock	
Penetrations		
<p>Must not allow moisture or condensation to run onto electronics or power cables.</p> <p>Kapsch TrafficCom warranty extends to manufacturer defects as delivered but does not cover environments, locations, or penetrations that invalidate the NEMA 4 rating.</p> <p>Deference is made to any specifications used by the agency to govern NEMA 4 enclosures on its roadways.</p>		
Grounding		
Use AWG 8 wire to connect to the earth – ground system.		

CTM Diagnostic Port pin out			
Connector Type			
Data Communications Equipment (DCE) pin assignment, 9-pin male connector.			
Lightning Suppression			
Not required.			
Pin Number	Signal	Description	Diagram
1	DCD	Carrier Detect input	
2	RXD	Receive Data input	
3	TXD	Transmit Data output	
4		n/c	
5	GND	Logic Ground	
6		n/c	
7	RTS	Request to Send output	
8	CTS	Clear to Send input	
9		n/c	

CTM Ethernet Ports 1 and 2 pin out			
Connector Type			
8 pin RJ45 female			
Lightning Suppression			
Recommended on all pins.			
Pin Number	Signal	Description	Diagram
1	BI_DA+	Bi-directional pair A +	
2	BI_DA-	Bi-directional pair A -	
3	BI_DB+	Bi-directional pair B +	
4	BI_DC+	Bi-directional pair C +	
5	BI_DC-	Bi-directional pair C -	
6	BI_DB-	Bi-directional pair B -	
7	BI_DD+	Bi-directional pair D +	
8	BI_DD-	Bi-directional pair D -	

SPM terminal block connections			
Connector Type			
Terminal block			
Lightning Suppression			
Recommended for all signal wires.			
Terminal Number	Signal	Description	Diagram
1	CGND	chassis ground, shield	
2	R-	Sync Rx (RS-422 -)	
3	R+	Sync Rx (RS-422 +)	
4	T+	Sync Tx (RS-422 +)	
5	T-	Sync Tx (RS-422 -)	
6	CGND	chassis ground, shield	

LPM RS-232 COM Port pin out			
Connector Type			
Data Terminal Equipment (DTE) pin assignment, DB9			
Lightning Suppression			
Recommended on pins 2, 3, 7, 8.			
Pin Number	Signal	Description	Diagram
1	DCD	Data Carrier Detect	
2	TXD	Transmit data output	
3	RXD	Receive data input	
4	DTR	Data Terminal Ready	
5	SGND	Signal ground	
6	DSR	Data Set Ready	
7	RTS	Ready to Send	
8	CTS	Clear To Send	
9	CGND	Chassis ground	

LPM RS-422 COM Port pin out			
Connector Type			
Data Terminal Equipment (DTE) pin assignment, DB9			
Lightning Suppression			
Recommended on pins 1, 2, 3, 4.			
Pin Number	Signal	Description	Diagram
1	TXD+	Transmit data output	
2	TXD-	Transmit data output	
3	RXD+	Receive data output	
4	RXD-	Receive data input	
5	NC		
6	NC		
7	NC		
8	NC		
9	NC		

Antenna Specifications

Antenna	IAG-1	IAG-3
P/N	800260-011	800260-015
Lane Kit #	TBC	802344-203
Description	3x3 patch	3x4 dipole array
Antenna Gain (dBi)	16 + 1	14 + 1
Width (inches)	34.75	34.5
Length (inches)	31.75	21.25
Thickness (inches)	2.3	3.13
Weight (lbs)	33	19
Mounting	horizontal	horizontal
Application	standard width or ORT lane	Standard Width or ORT lane
Straddle (feet) (min/max c to c)	5.5/6.5	5.5/6.5

Note: Mounting information is provided as a guideline.

Note: Weight specified is applicable to the antenna structure only i.e., it does not include mounting hardware

Antenna Environmental Specifications

Operating Temperature: -34C to 74C

Vibration:

Frequency	Displacement
Below 1 Hz	10 inch sway
1-4 Hz	1 inch sway
4-10 Hz	0.1 amplitude
11-15 Hz	0.03 amplitude
16-25 Hz	0.02 amplitude
26-30 Hz	0.01 amplitude
31-40 Hz	0.005 amplitude
41-50 Hz	0.003 amplitude
Shock (all direction):	15 G, 11 ms saw tooth
Wind:	160 mph
Peak Displacement:	6 inches

RF Cable Specifications

Kapsch TrafficCom recommends the following options for RF feedline cables.

Cable P/N	Manufacturer	Loss/100ft (dB)
LMR-400DB	Times Microwave	3.966
LMR-600DB	Times Microwave	2.542
LMR 900DB	Times Microwave	1.725
LDF4-50A	Andrews	2.1

The maximum cable length is limited by the permitted cable signal loss. The maximum cable signal loss is based on the protocols selected and is limited to the lowest value in the table below of all protocols enabled.

Protocol	Maximum cable loss (dB) MRFMS	Maximum Cable Loss (dB) MRFMS Plus
TDM	8	11
ISO18000-6C	8	11
ISO18000-6B	4	7
SeGo	4	7

10374/ATA/AAR S-

4

7

Connectors: Use cable assembly tools recommended by the cable manufacturer.

Cable splicing: No splices are allowed, must be a continuous run

Minimum Bend Radius: See Manufacturers recommendation

Finished connection must be weatherproofed using self-amalgamating tape

Cable that run underground or may be submersed in water must be installed in conduit with no other cables capable of inducing RFI or EMI.

Synchronization Cable and Terminal Block specifications

An example of the wiring detail is shown in Figure 5-11: Synchronization circuit schematic for three Readers, page 169. This cable must be run in conduit and should not be run with other cables capable of inducing RFI or EMI.

Maximum Sync Cable Length

2000 feet (607 meters) max length, sum of all Readers cable segments to hub

1500 feet (457 meters) max length, any one Reader cable segment to hub

Sync Cable Requirements

Temperature: as required for operating environment

Environmental: as required for operating environment (must be waterproof if immersion is possible)

Capacitance: 30 pF/ft or less

Sync Wire: 3 twisted pairs (2 active, 1 spare), shielded, single or multiple drain

Wire gauge: 24 AWG (minimum)

Sync Terminal Block

Temperature and Environmental: as required for operating environment

Number of terminals: [4 X (number of Readers in the sync group) plus 4] e.g. 3 Readers require $(4 \times 3) + 4 = 16$

Connection: See the example diagram of a three-Reader sync hub connection in Figure 5-11, page 169.

Spares and Tools

The following table lists the recommended spares for the JANUS reader and the Lane Kits.

Part Number	Description
801638-001	Configuration module - CFM

Part Number	Description
801701-003	Lane port module, RS422 - LPM
801701-002	Lane port module, RS232 - LPM
802311-001	Power supply module, primary - PSM
802311-002	Power supply module, secondary - PSM
307865-020	Fuse, time lag, 10A, 500V, power supply main input
801693-001	Sync port module, 2-wire RS485-SPM
801693-002	Sync port module, 4-wire RS485 - SPM
801693-003	Sync port module, 4-wire RS422 - SPM
480803022002	Controller module, RS422 - CTM
480803022001	Controller module, RS232 - CTM
802344-201	Lane kit, IAG-3
800260-011	Antenna, IAG-1
800260-015	Antenna, IAG-3
800125-001	Adapter cable, RF
802870-TAB	MRFM-S Plus Module
802295-TAB	MRFM-S module

Test Equipment

- Two-way radios
- Measuring device (Tape rule, Wheel)
- Lane marking materials (paint or other)
- Plumb bob (25ft. line length)
- Electronic Level (digital display)
- Tool kits, appropriate cables, connectors etc.

Test Vehicles

- Bucket / Lift Platform Truck
- Passenger Vehicle (Type to be determined by Kapsch Engineering)

Reference Documents

Doc number	Title
ICD 360430-100	Interface Control Document for the Next Generation Reader External Hardware Interface
ICD 360467-122	Lane Controller Interface Control document
322704-TAB	Calibration Procedures
322710-077	Gold Transponder and Production Tester Calibration and Maintenance Procedure
801850-002	Front Mount Exterior (FME) Transponder Mounting Instructions for passenger vehicles
801850-004	G4 Interior Transponder Mounting Instructions
801850-005	Front Mount Exterior (FME) Transponder Roof Mounting Instructions for trucks and buses
801850-006	Motorcycle Front Mount Exterior (FME) Transponder Mounting Instructions
801850-008	G4F Feedback Interior Transponder Mounting Instructions
801850-012	G4 Transponder Secure Mount Bracket Mounting Instructions
801850-014	G4P Permanent Interior Transponder Mounting Instructions
801850-015	Flat Pack Transponder (FPT) Mounting Instructions
801850-016	Roof-Mount Flat Pack Transponder (FPT) Mounting Instructions for trucks and buses
801850-018	Commercial Vehicle Operator (CVO) Self-Test Transponder Mounting Instructions
801850-019	Front Mount Exterior (FME) Transponder Front Mounting Instructions for trucks and buses
801850-020	Motorcycle Flat Pack Transponder (FPT) Mounting Instructions

Other commercial Documents

RuggedMC™ RMC40 Installation Guide

Acronyms and Synonyms

Term	Meaning	Reference or example
AC	Alternating current	
AM	Amplitude modulation	
AWG	American wire gauge	
BGR	Badger	a Kapsch TrafficCom manufactured Reader assembly
BOM	Bill Of Material	A parts list identifying individual components in the assembly of a system module
BPS	Bits per second	Data rate, or transmission speed
CAT	Category	an Ethernet cable type
CF	Compact flash	a memory storage type
CFM	Configuration Module	Non-volatile storage device containing the Reader configuration
CGC	Channel Group Controller Module	PWA board to handle the Manchester encoded RF protocol between the transponder and the Reader
CGND	Chassis ground	Common grounding mechanism for components within an enclosure or chassis. Typically earth grounded. The earth ground system must comply with the U.S. National Electrical Code (NEC) requirements for a grounding electrode.
CMOS	complementary metal-oxide semiconductor	a technology for manufacturing ICs
COM	communications	ex. COM port
COM	Communication module	In the Badger Reader, the Communication module provides the RS232/RS422 interface between the Reader and the Lane Controller. Note: Replaced by the LPM in the JANUS Reader..
computer	the service laptop computer or the LC host computer	
CPS	Cycles per second	Hertz
CPU	Central processing unit	
CRA	Cross Reader Algorithm	Badger Reader legacy algorithm (tag based) used to suppress duplicate transaction reporting to the Lane Controller
CTM	Controller Module	A plug-in module containing an assembly of CGC and MC
CTS	Clear to send	RS232 pin assignment
DA	data	

Term	Meaning	Reference or example
DB or dB	decibel(s)	unit of measurement of RF signal strength
DC	direct current	
DCD	Data carrier detect	RS232 pin assignment
DCE	Data communications equipment	RS232 port configuration, transmit is pin 2
deg.	degrees	
DIN	Deutsches Institut für Normung	German national standards organization
DSM	Distribution Module	Reader's back plane carrying DC power distributions to each module and signal connectivity between modules.
DSR	Data set ready	RS232 pin assignment
DTE	Data terminal equipment	RS232 port configuration, transmit is pin 3
DTR	Data terminal ready	RS232 pin assignment
EBX	embedded board expandable form factor	compatible with legacy PC104 form factor
EIA	Electronic Industry Association	
EMI	Electromagnetic Interference	Disturbance to radio signals and electronic circuits due to undesirable B-field emissions from an external source. See also RFI.
EMP	Electromagnetic Pulse	Strong disturbance that negates the ability of all exposed electronics in the affected area.
EN	enable	
ESD	electro-static discharge	
ESM	Ethernet Switch Module	Used to create an inter-Reader network of up to 3 Readers in ORT installations, improves Voting
ETC	Electronic Toll Collection	Collection of tolls using electronic mechanisms such as RFID tags and Readers
FCC	Federal Communications Commission	
FDM	Frequency Division Multiplexing	An RF module that is able to scan multiple OBUs from the frequency being emitted by them.
FME	Front Mount Exterior	An exterior tag in a weatherproof package mounted using the front license plate mounting holes. This item replaces the LPT tag
FPGA	Field Programmable Gate Array	the FPGA file defines the bit stream

Term	Meaning	Reference or example
FPT	Flat Pack Transponder	An interior tag in flat package mounted on the inside of the windshield
GND	ground	
HS	handshake	
HTTPS	Hypertext Transfer Protocol Secure	
Hz	Hertz	Cycles per second
I/O	input/output	
IC	Integrated circuit	
ICD	Interface Control Document	Specification of the physical interface, protocol and file formats used for messages sent between two communications components.
ID	Identity or Identifier	Group ID in RF Channel configuration
IEC	International Electrotechnical Commission	
IEEE	Institute of Electrical and Electronic Engineers	Worldwide non-profit professional organization that makes voluntary, consensus-based, standards
IF	Interface	
IP	Intellectual Property or Internet Protocol	reference an asset or reference an address
IR	Inter-Reader	
IRIF	Inter-Reader interface	An Ethernet network of Readers at an ORT site
ISO	International Organization for Standardization	International standards body. Members are the national standards bodies for each country.
LA	lane assignment	
LAN	Local Area Network	A local computer network for communication between computers
LC	Lane Controller	Controls Readers and receives data and alerts from Readers.
LCD	Liquid Crystal Display	Thin flat display device, using multi-colored pixels in front of a light source
LED	Light Emitting Diode	Used as status indicators on JANUS® Multi-Protocol Reader 2.4
LPM	Lane Controller Port Module	In the JANUS® Multi-Protocol Reader 2.4, this module provides a serial interface between the Reader and the Lane Controller

Term	Meaning	Reference or example
LPT	License Plate Transponder	An exterior tag in a weatherproof package mounted using the front license plate mounting holes (a legacy product now replaced by the FME)
MC	Main Controller	Intel-x86 based single-board computer that runs the Reader software
MRFM-S	Smart RF Module	The analog portion of the Reader and the termination point for coaxial cables from the antennas with command driven Tx and Rx attenuation.
N/A	not available	
NEC	National Electric Code	
NEMA	National Electrical Manufacturers Association	Sets standards for electrical components. Equipment enclosures with a NEMA rating meet a certain standard. NEMA-4 is generally considered watertight.
NTP	Network Time Protocol	
OBU	On Board Unit	Transponder or tag
ORT	Open Road Tolling	ETC from high speed vehicles that do not slow down and may straddle lanes
PC	Personal computer	
PF	Programming failure	transponder programming by the Reader
Pgm	Program or programmed or programming	context related usage
PID	Plaza ID	a configurable Reader parameter
PS	Power supply	
PSM	Power Supply Module	PWA board to provide AC/DC power to the Reader
PTO	Programming timeout	
PU	Programming unverified	transponder programming by the Reader
PWA	printed wiring assembly	All of the digital rack plug-in boards have PWAs
QMS	Quality management system	
R/W	Read / Write	
RAL	Restricted Access Location	Physical security enforced for safety and system integrity.
RAM	Random Access Memory	Data stored in this type of memory can be accessed in any order
Reader	JANUS® Multi-Protocol Reader 2.4	

Term	Meaning	Reference or example
RF	radio frequency	Broadcast band transmission frequencies
RFI	Radio Frequency Interference	Disturbance to radio signals and electronic circuits due to undesirable E-field emissions from an external source. See also EMI.
RFID	RF Identification	An automatic Identification methodology relying on storing and retrieving data remotely using OBUs or RFID Tags (transponders) and Readers.
RFIF	RF Interface	Internal connection from the CTM via the DSM to the RF modules
RID	Reader ID	a configurable Reader parameter
ROM	Read Only Memory	Data, such as software, in this type of storage device cannot be modified
RSE	Roadside Equipment	The collection of all AVI equipment at the roadside, including Reader, antennas, Ethernet switches, power supplies, cables and connectors. (incorrect, only includes Reader rack)
RTS	Ready to send	RS232 pin assignment
RX or Rx	receive or receiver	Communications or RF Module functions
RXD	Transmit data	RS232 pin assignment
SGND	System ground	
SMA	Sub-miniature version A	An RF connector type
SNR or S/N	Signal to noise ratio	A comparison of desired signal to the level of background noise.
SPM	Sync Port Module	PWA board to provide sync signals to the Reader via the termination network
SSH	Secure shell	
SSL	Secure sockets layer	Internet site security access via certificates
Sync	Synchronization	
TAB	Tabulation	System of indexing used for variations of assembly drawings. A drawing number ending in the suffix "-TAB" will have a list of all other variations of the drawing (can be from -001 to -999).
TC	Toll collection	a Reader application
TCP	Toll Collection Programming	Software modules used to collect tolls
TCP/IP	Transmission Control Protocol/Internet Protocol	The Internet Protocol Suite is the set of protocols used for the Internet, and other systems or Intranets

Term	Meaning	Reference or example
TDM	Time Division Multiplexing	An RF module that is able to scan OBUs through time sequencing by using time difference between one OBU and another.
TM	Traffic management	a Reader application
TMP	Traffic Management Programming	Software modules used for traffic management
TTO	Transponder timeout	
TX or Tx	transmit or transmitter	Communications or RF Module functions
TXD	Transmit data	RS232 pin assignment
UDP	User Datagram Protocol	an Internet protocol that is faster than TCP but offers no error correction
UL	Underwriter Laboratories	Underwriter Laboratories Inc.
URL	Uniform resource locator	
USB	Universal Serial Bus	Standard protocol for peripherals, enables plug-and-play
UTC	Coordinated Universal Time	the time standard used to regulate time around the world
VAC	Voltage AC	
VDC	Voltage DC	
VSWR	Voltage Standing Wave Ratio	

Glossary

Name Term or Component	Alias or explanation
Baud Rate	Physical transmission speed: bits, or changes in state, per second
Capture Zone	An area where an OBU is detected by the MRFM-S (Plus).
Capture Zone Span Time	The amount of time it takes an OBU to pass through a capture zone.
Channel	One RF channel or one lane of traffic
Dummy frame	A time interval placeholder
Dynamic voting	A reader mode in which the voting time is dynamically set according to prevailing traffic speeds on a channel-by-channel basis.
Earth ground system	The earth ground system must comply with the U.S. National Electrical Code (NEC) requirements for a grounding electrode.
Express Lane - Wide	No barriers between lanes, straddle antennas required. Same as ORT
feedline	The cable that carries the RF signal to or from the antenna. Also called transmission line.
frame	one scan of an RF Channel. There can be a maximum of eight frames for one Reader
Format Incompatible report	A report sent to the Lane controller, generated when a non-TDM tag is seen by the Reader.
Host Computer	Not supplied by Kapsch TrafficCom. Computer used to monitor/control the LC within the Toll Plaza. The Reader is accessible to a Toll Plaza Host computer (if available) via the web interface.
Inter-Reader network	An Ethernet network of Readers at an ORT site used for ORT installations having more than 8 regular-width lanes (or 5 wide lanes) in one direction
Lane assignment	The process of providing a transaction report to the lane controller, with the intent of correctly identifying the lane of travel of the transponder equipped vehicle. The overall goal is high programming success rate, high lane assignment accuracy, and low consistent reporting latency.
Majority (Voting)	A lane assignment mode where the channel with the most handshakes is deemed to be the assigned channel.
Non-Redundant Reader	A Reader having only the Secondary Reader, used for Vehicle Identification or Traffic Control Management applications
Plaza	Structure for toll collection, typically with barriers between lanes and canopy overhead. Vehicles slow for ETC.
Primary Side	Primary CTM (or the set of Primary Reader components)

Name Term or Component	Alias or explanation
Reader	Generic term for the JANUS redundant Reader in this manual
Redundant Reader	A toll collection Reader having both Primary and Secondary controller modules.
Redundant Side	Secondary CTM (or the set of Secondary Reader components)
Service Laptop Computer	Service tool used to configure, setup, troubleshoot, and monitor the Reader.
Skip-on-sync	Skip-on-sync indicates what protocol the reader should start reading next.
Superframe	A configuration used for MPR2 and earlier versions of Reader software. The total number of frames that can be scanned in a Reader.
Status File	OBU Account Status File supplied by the client and made available in the lane controller for download to the Reader.
Tag	Transponder or OBU
Transponder	Tag or OBU
Voting Time	Represents the time delay after the initial read of the tag, at which point the Reader determines the lane assignment for the OBU in the transaction report sent to the lane controller.
Wide lane	A standard-width lane is 10 to 12 feet wide. Wide lanes are 12 to 14 feet wide.

Differences between MPR2.4 and MPR 2.3

The main differences are:

- Faster processor.
- Updated user interface.
- Optional Wizard based setup.
- Increased reader log file capacity:
Event log capacity increased to 50 MB (from 20 MB for MPR 2.3)
Tag transaction log capacity to 100 MB (from 20 MB for MPR 2.3)

Differences between MPR2.4 and the Badger and JANUS Readers

ATTENTION 1: A JANUS Multi-protocol Reader 2.4 (MPR2.4) that is non-redundant uses primary-side hardware components whereas the JANUS non-redundant reader uses secondary-side hardware components.

ATTENTION 2: The software of a JANUS Multi-protocol Reader 2.4 (MPR2.4) that is non-redundant is locked in Primary mode; the mode switch mechanical position is ignored. The software of a JANUS non-redundant reader is locked in Secondary mode; the mode switch mechanical position is ignored.

Users familiar with the Badger Reader application for ORT must note the following changes with respect to the use of the Kapsch TrafficCom JANUS ETC Subsystem:

Note 1: Connection of the JANUS Readers in an inter-Reader network allows adjacent Readers to vote on the lane assignment used for the transaction report.

Note 2: Shared antennas are no longer required between Readers.

Note 3: The 4-channel scan configuration is no longer needed.

Note 4: Reporting latency is 50 ms for the JANUS MPR2.4 reader in multi-protocol operation, 25 ms for JANUS MPR2.4 in TDM only operation, 5 ms for the JANUS Reader, and was 35 ms for the Badger Reader. Use the configuration parameter LC Report Latency by Tag Type (on LC page) to slow down the transaction reports to the LC for those legacy sites where the LC is expecting Badger Reader timing.

Note 5: There is no theoretical upper limit to the number of ORT lanes that can be supported with multiple co-located Readers.

Note 6: The IAG-3 antenna is recommended for use in JANUS ORT applications. (The IAG-2 antenna currently used in toll plaza lanes is not recommended.)

The JANUS and Badger Reader features are compared in Table 7-1.

Table 7-1: Important Differences between the Badger Reader and the JANUS Reader

Feature	JANUS	Badger	Notes
Performance Features			
Synchronization	Y	Y	Compatible performance with Badger Reader 4 wire sync circuit. (Not compatible with IAG Reader 2 wire sync circuit). Only syncs on 8 or 10 channel scan.
Reader redundancy	Y	Y	Automatic switchover upon failure to the redundant Reader without data loss.
Variable channel scan configuration	Y	Y	Improve handshakes per channel for ORT
Cross Reader Algorithm (via tag)	Y	Y	Dependent on successful tag programming.
Cross Reader Voting (via Ethernet link)	Y		
Dynamic Voting	Y		

Feature	JANUS	Badger	Notes
Channel weighting	Y	Y	Option to de-emphasize straddle antenna (ORT)
Early read voting delay	Y		Handshaking is continued for a longer period of time to include both sides of any gap in reading individual tags
Low read voting delay	Y		
Adjacent channel programming	Y		
Look for tags on adjacent channels	Y		Improve read performance
Implied Channel Groups		Y	global voting time (BGR), TTO
Configurable channel groups	Y		separate voting time, TTO, etc per group
Interleaved programming mode	Y	Y	
Non-interleaved programming mode	Y		
Read/Write Operation	Y	Y	Compatible handshake performance.
Improvement of Write performance	Y		Continue write attempts after voting ends
No tag programming on a Guard channel	Y	Y	
Dual read per frame	Y		Performance improvement
Tx/Rx Attenuation Control	Y		Power on each antenna is configurable
Lane Controller & Reporting Features			
Filter out Non-IAG tags	Y		Non-IAG tags are not reported – configurable feature
Lane Assignment	Y	Y	Compatible performance (capture rate, read/write operation)
Support 8 LC Serial ports	Y	Y	
Max Serial port speed (kbps)	115.2	57.6	BGR max is on 5 ports
Support LC Ethernet interface	Y		
Support Inter-Reader Ethernet interface	Y		
Host Port support		Y	
Re-Report	Y		re-report a tag in zone
Initial Read Report	Y		
Post capture zone report	Y		

Feature	JANUS	Badger	Notes
Transaction buffering	Y	Y	JANUS: 1 million non-volatile BGR: 80K IAG: 1K
Reset transaction number	Y		Accept a Lane Controller command to reset OBU transaction number to zero
Latency measurement & reporting	Y		
Status File Download for Feedback OBUs	Y		up to 40 million OBUs in the file
Feedback OBU support	Y		Beeper and LED on OBU supported
Maintenance Features			
Web interface for local/remote Reader HTTPS access and control	Y		Viewing/modify Reader configuration, view status, download/run software, manage OBU Status file
Real time reporting of transactions on web interface	Y		
Multiple users & permissions per user	Y		
Zero re-configuration upon processor module (CTM) replacement	Y		When a CTM is swapped, Reader configuration parameters are retained in the CFM (a non-volatile memory off board from the CTM).
Save Reader Configuration File to laptop (also IP addresses and permissions passwords)	Y		Transition process is made easier. During service process, reload the original instead of manual setting many parameters.
Remote reset (reboot)	Y		reset via a lane controller or the web interface
Software/Firmware download	Y		
Maintain multiple software/firmware images	Y		At least 6 versions, including factory image.
Automatic switchover recovery	Y		Reader will return control to Primary without operator intervention.
Copy reader logs to USB stick	Y		
Diagnostics			
Diagnostic Port	Y	Y	
Load monitoring (CPU/Mem)	Y		Allows anomaly detection.
High Speed Margin Diagnostic	Y		Proof of concept
Trouble Log	Y		
Transaction Log	Y		Temporary transaction log

Feature	JANUS	Badger	Notes
Event log	Y	Y	MPR2.4 50 MB; BGR & IAG: 10 events
Other			
Network Time Protocol	Y		Allows NTP to sync date and time for all Readers in a network
Feedback OBU activation – Option 1	Y	Y	BGR205 firmware
Dual Reporting Mode (Redundancy Reporting)	Y		Improved processing redundancy handling (JANUS Reader Phase 2).
HARDWARE			
The JANUS non-redundant Reader uses the secondary side components. The JANUS non-redundant MPR 2.4 reader uses the primary side components.	Y		The Badger non-redundant Reader uses the primary side components
The JANUS non-redundant Reader software is locked in Secondary mode; the mode switch mechanical position is ignored. The JANUS non-redundant MPR 2.4 reader software is locked in Primary mode; the mode switch mechanical position is ignored.	Y		The Badger non-redundant Reader mode switch is mechanically locked in the “primary” position.

Appendix B FCC Approved Channel Frequencies and Selection

The frequency plan used at a toll site is dependent on the antenna spacing rules, local RF interferers and the approved FCC (or other applicable regulatory body) frequencies.

RF Module FCC ID JQU 802295A and also RF Module with Amplifier FCC ID JQU 802295A-A are approved for 30W ERP radiated power by the FCC for the following protocols.

JQU802295A and JQU 802295A-A – FCC Approved Frequencies

FDM Protocols	902-904 MHz Sub-Band	909.75-921.75 MHz Sub-Band
ATA	902.5-903.5	910-921.5
6B	n/a	911-920.5
SeGo	n/a	911.5-919.5
6C	903	910.5-920.5
TDM/mixed Protocols		
TDM	n/a	915.75

JQU802870 – FCC Approved Frequencies

FDM Protocols	902-904 MHz Sub-Band	909.75-921.75 MHz Sub-Band
ATA	902.5-903.5	910-921.5
6B	903	910.5-920.5
SeGo	n/a	911-920
6C	903	910.5-920.5
TDM/mixed Protocols		
TDM	n/a	915.75

In addition the following rules apply for FDM protocols:

The same channel frequency should not be used on adjacent lanes, including straddle and shoulder lanes (recommended at least 24 ft separation between in-line antennas and 21 ft. separation between staggered arrangement antennas).

The frequency spacing used shall be at least 2.5 MHz between adjacent antennas (i.e. in-line or straddle antennas).

For 6C read in ORT an in-line configuration can be used. For all other FDM protocols in ORT and for 6C write in ORT a staggered configuration should be used.

For the in-line and staggered antenna configurations outlined in **Installing a Lane Kit**, page 159, this means that a 4 or more channel frequency plan (i.e. can repeat every 5th antenna) must be used for in-line configurations and a 3 or more channel frequency plan (i.e. can repeat every 4th antenna) must be used for staggered configurations.

For example within the FCC limits and a staggered ORT antenna configuration a suitable selection can be made that covers all protocols with the following ranges











F1	F2 (+2.5 MHz)	F3 (+5.0 MHz)
911.5 to 914.5	914 to 917	916.5 to 919.5

For example using this, a larger 7 channel frequency plan can be easily realized respecting all the rules on a staggered site.

Antenna #	1	2	3	4	5	6	7
Position	Main	Straddle	Main	Straddle	Main	Straddle	Main
Frequency (Mhz)	911.5	914	916.5	919	911.5	914	916.5

Appendix C UI Reader Status Indicators

The reader web page banner provides a number of status indicators. The following indicate problem conditions:

 LC	Indicates a problem with one or more lane (zone) controllers or the connections to those lane (zone) controllers.
 Sync	Indicates problem with Reader to Reader Synchronization.
 NTP	NTP is enabled, but there is a NTP connection issue, or the reader's time offset is higher than the configured maximum limit. Check the configured NTP IP address settings on the Time page.
 CGC	Indicates a problem with the reader Channel Group Controller (CGC). The reader software automatically attempts to resolve this issue.
 Frame Config	Indicates a problem with the Reader frame sequence configuration. Check the Tag Protocols page. An empty protocol frame sequence can trigger this.
 IR	Indicates a problem connecting with adjacent readers via the Inter-Reader (IR) network. Check inter-reader settings on all readers.
 CPU load	The reader CPU load is high (above 50%).
 CPU load	The reader CPU load is extreme (above 80%).
 Reader Comms	The browser UI can't communicate with the reader. Trouble shoot: Check if the reader has been powered off. Check if a gateway setting is configured when not required.
 SW	The reader software is different between the Primary and Secondary side.

Appendix D Non-redundant reader

The non-redundant Reader consists of:

Note: Numbers in the list below refer to those associated with the illustration below. The DSM, and CFM are not shown.

- One rack and Distribution Module ❶
- MRFM-S (Plus) modules (up to 4 modules can be installed) ❷
- One Power Supply Module (PSM) and AC Power Cord ❸
- One Lane Port Modules (LPM) ❹ (Reader Model Dependent)
- One Controller Module (CTM), ❺ equipped with one Main Controller (MC), one Channel Group Controller (CGC)
- One Configuration Module (CFM) that attach directly to the DSM (not shown)
- One Synchronization Port Module (SPM) ❻

The following illustration shows the non-redundant reader setup with the right hand configuration. A left hand configuration is also available.

